

# Table of Contents

<b>1. Introduction</b>	5
Step 1 - General information	6
Step 2 - How to navigate through the manual	6
Step 3 - What awaits you during the unpacking	7
Step 4 - Tools in the package	8
Step 5 - Labels guide	8
Step 6 - Cheatsheet	9
Step 7 - Prusa nextruder sock	9
Step 8 - CAUTION: Lubricant Handling	10
Step 9 - View high resolution images	10
Step 10 - We are here for you!	11
<b>2. Printer unboxing</b>	12
Step 1 - Introduction	13
Step 2 - Opening the package	13
Step 3 - Opening the package	14
Step 4 - Removing the inserts	14
Step 5 - Removing the inserts	15
Step 6 - Removing the inserts	15
Step 7 - Unpacking the printer	16
Step 8 - Haribo time	16
Step 9 - Printer is ready for setup	17
<b>3. Printer set up</b>	18
Step 1 - Tools necessary for this chapter	19
Step 2 - Injection molded xLCD: parts preparation	19
Step 3 - Injection molded xLCD: xLCD cables	20
Step 4 - Injection molded xLCD: mounting the xLCD	20
Step 5 - Printed xLCD: parts preparation	21
Step 6 - Printed xLCD: xLCD cables	21
Step 7 - Printed xLCD: mounting the xLCD	22
Step 8 - Preparing the printer	22
Step 9 - Nextruder cable: parts preparation	23
Step 10 - Nozzle seal versions	23
Step 11 - Nozzle seal not pre-installed: nextruder dock preparation	24
Step 12 - Guiding the nextruder cable	25
Step 13 - Attaching the first and second nextruder dock	26
Step 14 - Dock inspection	26
Step 15 - Dock inspection: video	26
Step 16 - Third dock: removing the screw	27
Step 17 - Nozzle seal not pre-installed: parts preparation	27
Step 18 - Nozzle seal not pre-installed: assembly	28
Step 19 - Nozzle seal not pre-installed: installation	28
Step 20 - Reward yourself	29
Step 21 - Wi-Fi antenna holder versions	29
Step 22 - Side version: Connecting the nextruder cables	30
Step 23 - Side version: Removing the XL buddy box cover	30
Step 24 - Side version: Connecting the Nextruder cables	31
Step 25 - Side version: Covering the XL buddy box	31
Step 26 - Side version: Guiding the PTFE tubes	32
Step 27 - Side version: Guiding the PTFE tubes, part 2	32
Step 28 - Side version: Installing the Wi-Fi antenna: parts preparation	33

Step 29 - Side version: Installing the Wi-Fi antenna .....	33
Step 30 - Back version: Wi-Fi antenna holder: parts preparation .....	34
Step 31 - Back version: Installing the Wi-Fi antenna: antenna preparing .....	34
Step 32 - Back version: Installing the Wi-Fi antenna: antenna preparing .....	35
Step 33 - Back version: Connecting the nextruder cables .....	35
Step 34 - Back version: Installing the Wi-Fi antenna holder .....	36
Step 35 - Back version: Connecting the Nextruder cables .....	36
Step 36 - Back version: XL buddy box covering .....	37
Step 37 - Back version: Guiding the PTFE tubes .....	37
Step 38 - Back version: Guiding the PTFE tubes, part 2 .....	38
Step 39 - Back version: Installing the Wi-Fi antenna: parts preparation .....	38
Step 40 - Back version: Installing the Wi-Fi antenna .....	39
Step 41 - Spool holder assembly versions .....	39
Step 42 - Printed spool holder: parts preparation .....	40
Step 43 - Printed spool holder: left side .....	40
Step 44 - Printed spool holder: Assembly .....	41
Step 45 - Printed spool holder: Mounting the assembly .....	41
Step 46 - Printed spool holder: right side assembly .....	42
Step 47 - Injection molded spool holder: parts preparation .....	42
Step 48 - Injection molded spool holder: adjusting the nut .....	43
Step 49 - Injection molded spool holder: Assembly .....	43
Step 50 - Injection molded spool holder: Preparation .....	44
Step 51 - Injection molded spool holder: left side assembly .....	44
Step 52 - Injection molded spool holder: right side assembly .....	45
Step 53 - Nextruder assembly: parts preparation .....	45
Step 54 - Docking the Nextruder .....	46
Step 55 - Nextruder cable bundle assembly .....	46
Step 56 - Nextruder cable bundle assembly versions .....	47
Step 57 - Two screws version: Nextruder cable bundle assembly .....	47
Step 58 - No screws version: Nextruder cable bundle assembly .....	48
Step 59 - Reward yourself .....	48
Step 60 - Almost done! .....	49
<b>4. First run .....</b>	<b>50</b>
Step 1 - Before you start with Multi-Tool .....	51
Step 2 - Nozzle seal height calibration .....	51
Step 3 - Nozzle seal height calibration .....	52
Step 4 - Nozzle Seal Adjustment .....	52
Step 5 - Preparing the printer .....	53
Step 6 - Firmware update .....	53
Step 7 - Checking the print fan type .....	54
Step 8 - Setting silver print fan .....	54
Step 9 - Wizard: Network and Prusa Connect setup .....	55
Step 10 - Wizard: Calibration tests .....	55
Step 11 - Wizard: Dock Position Calibration .....	56
Step 12 - Wizard: Remove the dock pins .....	56
Step 13 - Wizard: Loosen screws .....	57
Step 14 - Wizard: Lock the tool .....	57
Step 15 - Wizard: Tighten the upper screw .....	58
Step 16 - Wizard: Tighten the lower screw .....	58
Step 17 - Wizard: Install the dock pins .....	59
Step 18 - Wizard: Dock successfully calibrated .....	59
Step 19 - Wizard: Loadcell test .....	60
Step 20 - Wizard: Calibrate Filament Sensors .....	60
Step 21 - Wizard: Calibrate Filament Sensors .....	61

Step 22 - Calibration pin: parts preparing .....	61
Step 23 - Calibration pin: parts assembly .....	62
Step 24 - Wizard: Tool Offset Calibration .....	62
Step 25 - Wizard: Sheet install .....	63
Step 26 - Wizard: Calibration pin installation .....	63
Step 27 - Wizard: Offset calibration done .....	64
Step 28 - Calibration pin .....	64
Step 29 - Wizard: Phase stepping .....	65
Step 30 - It's done .....	65
Step 31 - Prusa nextruder sock (Optional) .....	66
Step 32 - Regular printer maintenance .....	66
Step 33 - Quick guide for your first prints .....	67
Step 34 - Printable 3D models .....	67
Step 35 - Give us feedback .....	68
Step 36 - Prusa knowledge base .....	68
Step 37 - Join Printables! .....	69
Step 38 - Haribo time! .....	69
<b>Manual changelog Five-Head (Assembled) .....</b>	<b>70</b>
Step 1 - Version history .....	71
Step 2 - Changes to the manual (1) .....	71
Step 3 - Changes to the manual (2) .....	72
Step 4 - Changes to the manual (4) .....	72
Step 5 - Changes to the manual (5) .....	73
Step 6 - Changes to the manual (6) .....	73
Step 7 - Changes to the manual (7) .....	74



# 1. Introduction



## STEP 1 General information

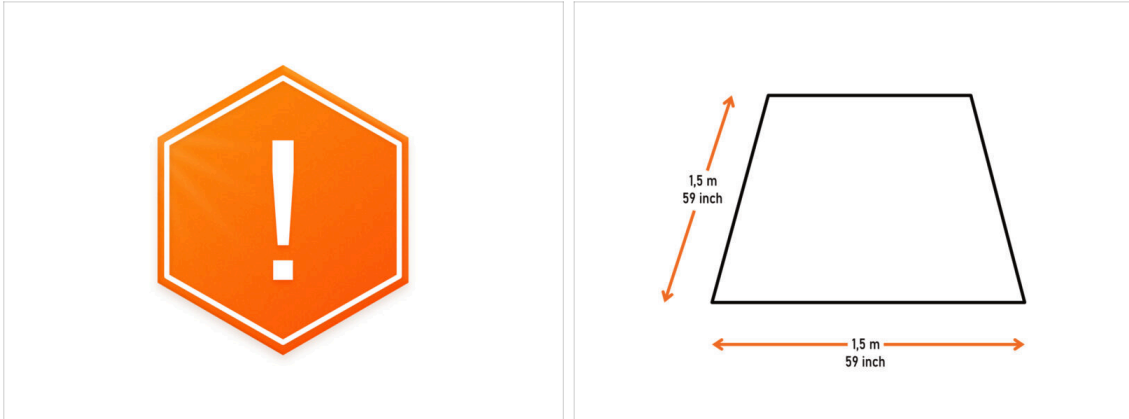

**⚠ The package with the printer is heavy! Always ask another person for help with handling.**

- **For the assembly, prepare a clean workbench with a space of at least 1,5 m x 1,5 m (59 in x 59 in).**
- **We recommend a bright light above your workbench. Some parts of the printer are dark, and inadequate light could make the assembly more difficult.**

## STEP 2 How to navigate through the manual

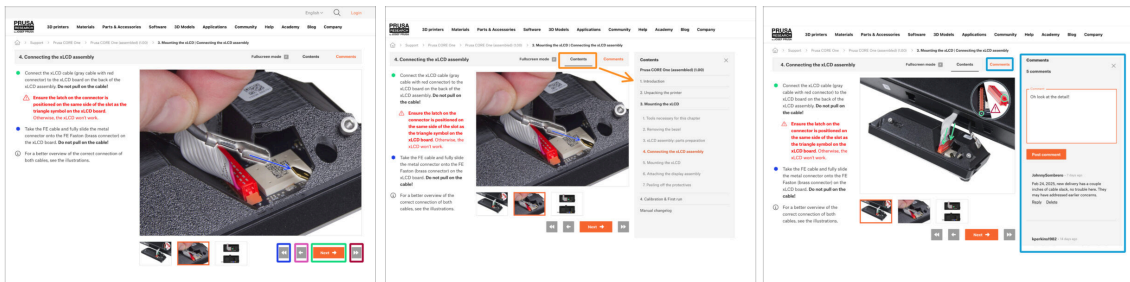

- **Use the graphical navigation buttons in the bottom right corner or the arrow keys on your keyboard:**
  - **Next button / Right arrow key** - Moves to the next image, or to the next step if it's the last image in the step.
  - **Left arrow button / Left arrow key** - Moves to the previous image, or to the previous step if it's the first image in the step.
  - **Play backward button / Up arrow key** - Moves to the previous step.
  - **Play forward (Next) button / Down arrow key** - Moves to the next step.
- **Click on Contents** to expand the full list of steps in this guide. This allows you to jump to any step regardless of the sequence.
- **Click on Comments** to open the discussion for a specific step and leave your feedback.

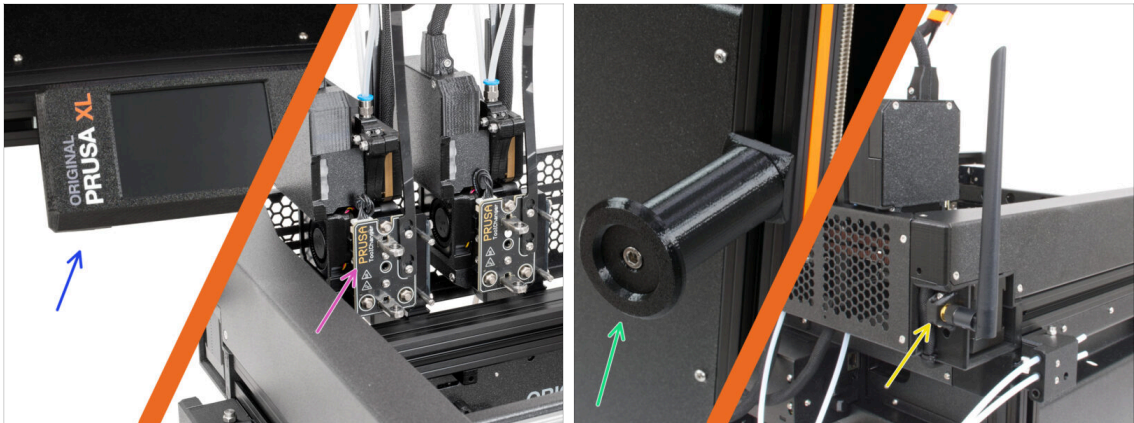
**STEP 3** What awaits you during the unpacking

**i** Because of transportation, some of the fragile parts must be safely packed separately in the printer package. This manual will take you through the installation of these parts on the printer.

**⚠ Do not discard the packaging!** Please keep the original packaging and protective foam. The printer must be packed in these for any service or warranty shipping to prevent damage.

**● These parts will be installed:**

- xLCD assembly
- Multi-Tool nexttruder assembly
- Spool holder
- Wi-Fi antenna

## STEP 4 Tools in the package



### ◆ The package includes:

- ① Some of the tools are intended primarily for regular printer maintenance. You might not need them for this manual. A list of the necessary tools is included at the beginning of each assembly chapter.
- ◆ Torx key TX6, TX8, TX10
- ◆ Allen key 2.5 mm, 4.0 mm
- ◆ Wrench 13-16
- ◆ Universal wrench
- ◆ T10 screwdriver
- ◆ Philips PH2 screwdriver
- ◆ Needle-nose pliers
- ◆ The printer's package contains a lubricant, which is intended for maintenance. No need to apply it during the assembly.

For tips on how to apply the lubricant, see our Regular printer maintenance guide.

## STEP 5 Labels guide

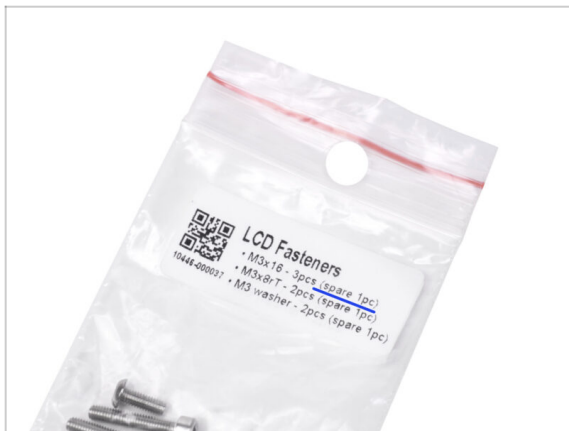

- ① All the boxes and bags that include parts needed for the build are labeled.
- ◆ The LCD Fasteners bag includes an extra spare of each part contained in the bag. The amount of spare parts is written on the label. This number is included in the total number of each type of part.

## STEP 6 Cheatsheet



- ◆ Your package contains a letter, on the back of which is a Cheatsheet with drawings of all the necessary fasteners.
- ◆ The fasteners drawings are 1:1 scale, so you can compare the size by placing the fastener on the paper to make sure you are using the correct type.
- i You can download it from our site [prusa.io/cheatsheet-xl](http://prusa.io/cheatsheet-xl). Print it at 100 %. Do not rescale it, otherwise it will not work.

## STEP 7 Prusa nextruder sock



- ◆ A silicone nextruder sock is supplied with each Nextruder package.
- ◆ Installing the Prusa nextruder sock is recommended, but optional. **We will provide details on how to install it later on in the guide.**
- i The main function of a silicone sock is to keep the temperature in the heater block stable, which improves the printer's performance.
- i Also, it keeps your hotend clean from filament debris and protects it in case the print detaches from the print surface.

## STEP 8 CAUTION: Lubricant Handling

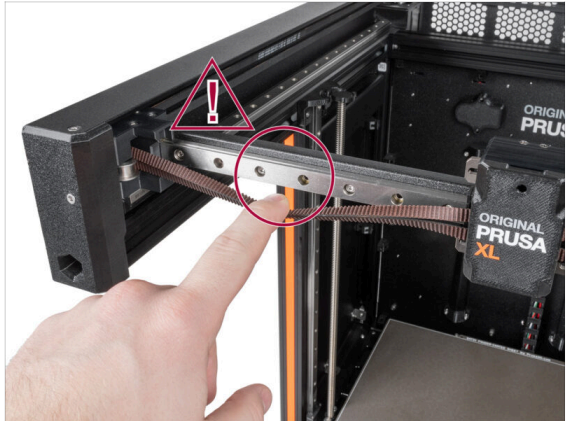
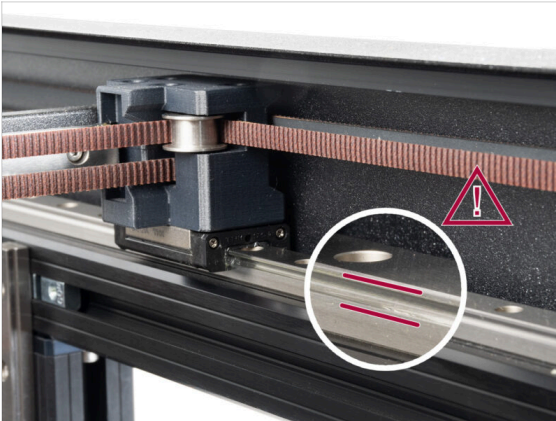

**⚠ CAUTION: Avoid direct skin contact with the lubricant used for the linear rails in this printer. If a contact occurs, wash your hands immediately. Especially before eating, drinking, or touching your face.**

- Lubricant accumulates in the printer's bearings, mainly in the linear rail channels.

## STEP 9 View high resolution images

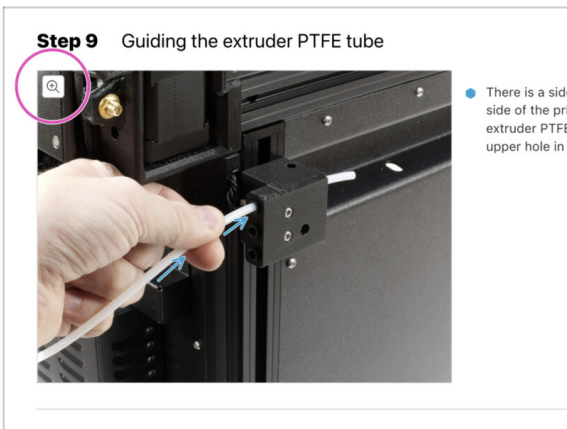

**i** When you browse the guide on [help.prusa3d.com](https://help.prusa3d.com), you can view the original images in high resolution for clarity.

- ◆ Hover your cursor over the image and click the Magnifier button ("View original") in the top left corner.

## STEP 10 We are here for you!

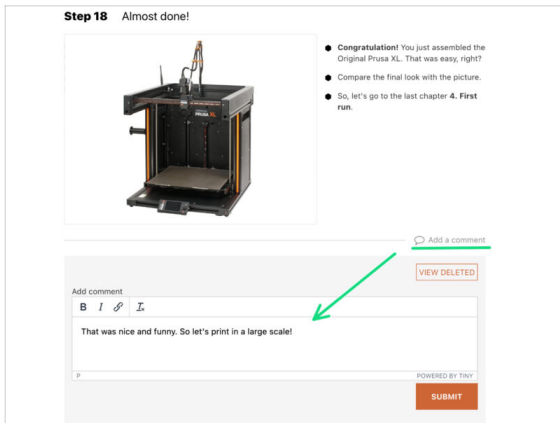
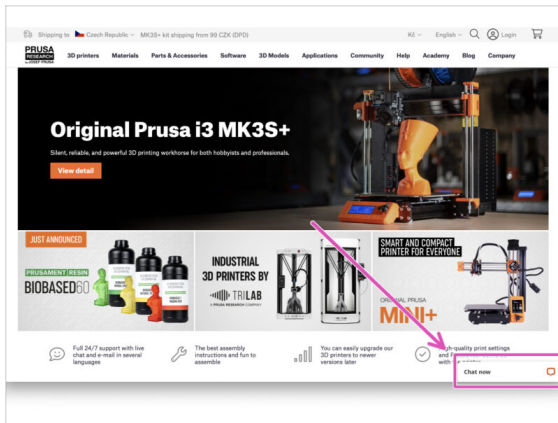

- Lost in the instructions? Missing screw or cracked printed part? **Let us know!**
- You can contact us using following channels:
  - Comments under each step.
  - Our 24/7 live chat at [shop.prusa3d.com](https://shop.prusa3d.com)
  - Writing an email to [info@prusa3d.com](mailto:info@prusa3d.com)
- Are you ready to get started on the assembly? Let's move on to chapter **2. Printer unboxing.**

## 2. Printer unboxing



### STEP 1 Introduction



- ⚠ **The printer package is heavy!** Ask someone to help you out.
- ⚠ **If any children are helping you with the assembly, always supervise them to avoid injury.**
- ⚠ **Do not discard the packaging!** Please keep the original packaging and protective foam. The printer must be packed in these for any service or warranty shipping to prevent damage.

### STEP 2 Opening the package

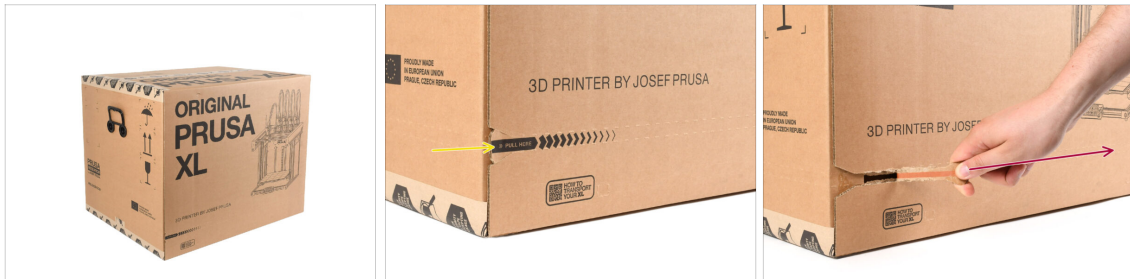

- Place the package on a stable surface. **Make sure that the package is oriented top side up.** Note the arrows on the box.
- The package is equipped with a tear strip that splits the box in two parts.
- Peel off the entire tear strip to split the box.

### STEP 3 Opening the package



Remove the top part of the box by lifting it up.

**⚠** Inside, there are cardboard inserts that contain parts necessary for the assembly. **Do not throw them out!**

**i** Your printer may differ slightly from the one shown in the photos. This does not affect the guide; the photos are for illustrative purposes only.

- Remove the Haribo gummy bears from the back of the box and put them aside. We will release them from captivity soon.
- Remove the welcome letter, which also contains the cheatsheet. **Do not dispose of the welcome letter!**

### STEP 4 Removing the inserts



- Remove the top hardened cardboard protective fixations.
- Remove the top foam fixations.
- Remove the top front cardboard insert. There are various parts inside, be careful not to lose these as you remove the cardboard insert.
- Remove the cardboard insert.
- Remove the five boxes containing nextruder parts.

## STEP 5 Removing the inserts



- Lift the two flaps on the side of the front cardboard insert, bend the vertical side down, and remove the insert.
- Remove the box with Prusament on top.
- Remove the test print by carefully lifting the corner of the print sheet where the print is located. Slightly bending the print sheet like this will make the print snap out from the surface.

## STEP 6 Removing the inserts



- There is a small cut-out in the top cardboard insert that locks it to the printer's frame. Pull it to unhook the insert.
- Unhook the protective cardboard strip that is wrapped around the X-axis.
- Printer parts are stored inside the top cardboard insert! Make sure not to lose them!
- Lift the whole insert and remove it.

## STEP 7 Unpacking the printer



- Use the side handles on the printer to lift it up.
- Keep the bottom of the box in place by holding it down while you lift the printer up.
- ⚠ **Do not lift the printer by the top metal profiles!!!** Otherwise, you may warp the printer parts and damage the LED lighting inside.
- ⚠ **Do not lift the printer alone;** ask someone to help you lift the printer by the handle on the side of the printer.

## STEP 8 Haribo time

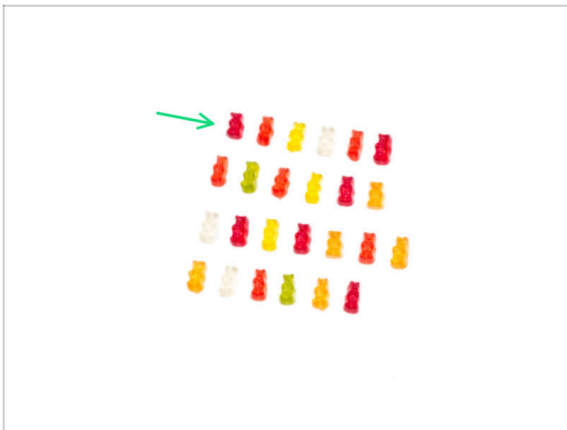

- ⚠ Carefully and quietly open the bag with the Haribo gummy bears. A high level of noise might attract nearby predators!
- Take out some of the gummy bears and place them on a clean surface. Separate the sleuth into four rows as shown in the photo. Seal the bag and set it aside for now.
- Eat the first row: six gummy bears.
- ⓘ **Did you know that** gummy bears were first created by a German candy maker named Hans Riegel in the 1920s.

## STEP 9 Printer is ready for setup



- ◆ Good job! The printer is ready for the next chapter.
- ◆ Visit chapter **3. Printer set up**.

### 3. Printer set up



## STEP 1 Tools necessary for this chapter



● **For this chapter, please prepare:**

- T10 Torx key

ⓘ You can also use a T10 screwdriver, which is included in the package

- 2.5 mm Allen key

- 4.0 mm Allen key

- Use a cardboard box as a heatbed protection during the setup. Use one of the Nextruder boxes that you received with your printer.

## STEP 2 Injection molded xLCD: parts preparation



ⓘ **Starting from September 2024, you may receive a new injection-molded xLCD. Check the photos and identify your version.**

- If you have the injection-molded xLCD, proceed with this step and continue to the next step →

● **If you have the older printed version of the xLCD, continue to this step: Printed xLCD: parts preparation**

● **For the following steps, please prepare:**

- xLCD assembly (1x)

- M3x10 screw (2x)

### STEP 3 Injection molded xLCD: xLCD cables

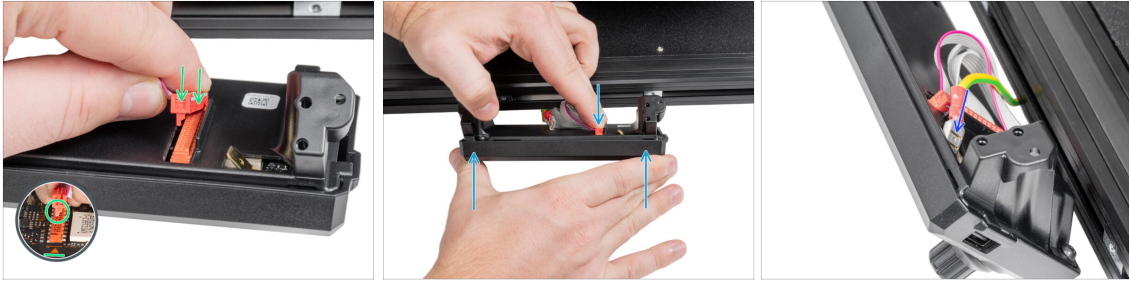

- ◆ Connect the xLCD cable to the slot on the xLCD board.
- ⓘ There is a latch on the xLCD cable connector, which must be facing the triangle symbol on the board. See the picture.
- ◆ Push the xLCD cable connector to fully connect to the xLCD. Hold the xLCD cover.
- ◆ Push the grounding connector fully into the PE faston.

### STEP 4 Injection molded xLCD: mounting the xLCD



- ◆ Align the xLCD assembly with the nuts in the front aluminum extrusion.
- ◆ Insert and tighten the M3x10 screw from the right side of the xLCD.
- ◆ Insert and tighten the M3x10 screw from the left side of the xLCD.
- ◆ The injection-molded xLCD is mounted and ready.
- ◆ **Proceed to this step: Preparing the printer**

## STEP 5 Printed xLCD: parts preparation



◆ For the following steps, please prepare:

- ◆ xLCD assembly (1x)
- ◆ M3x16 screw (2x)

## STEP 6 Printed xLCD: xLCD cables

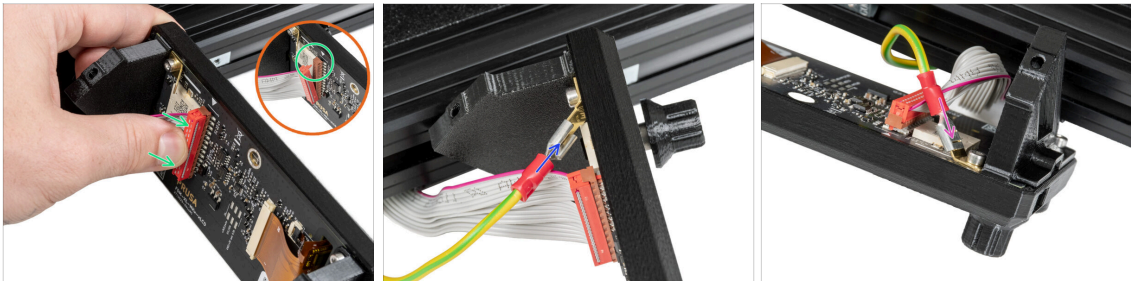

- ◆ Carefully turn the printer so that the front side is facing you.
- ◆ From the front of the printer, place the xLCD assembly close to the lower front aluminum extrusion where the xLCD cables are.
- ◆ Connect the xLCD cable to the slot on the xLCD board.
  - ⓘ There is a latch on the xLCD cable connector, which must be facing the triangle symbol on the board. See the detail.
- ◆ Connect the grounding cable and connect it to the PE connector on the xLCD.
- ◆ Push the grounding connector fully into the PE faston.

## STEP 7 Printed xLCD: mounting the xLCD



- ◆ Align the xLCD assembly with the profile nuts (M3nEs) in the front aluminum extrusion.
  - ⓘ Profile nuts (M3nE) are already installed in the aluminum profile by Prusa production department.
- ◆ Insert and tighten the M3x16 screw from the left side of the xLCD.
- ◆ Insert and tighten the M3x16 screw from the right side of the xLCD.

## STEP 8 Preparing the printer

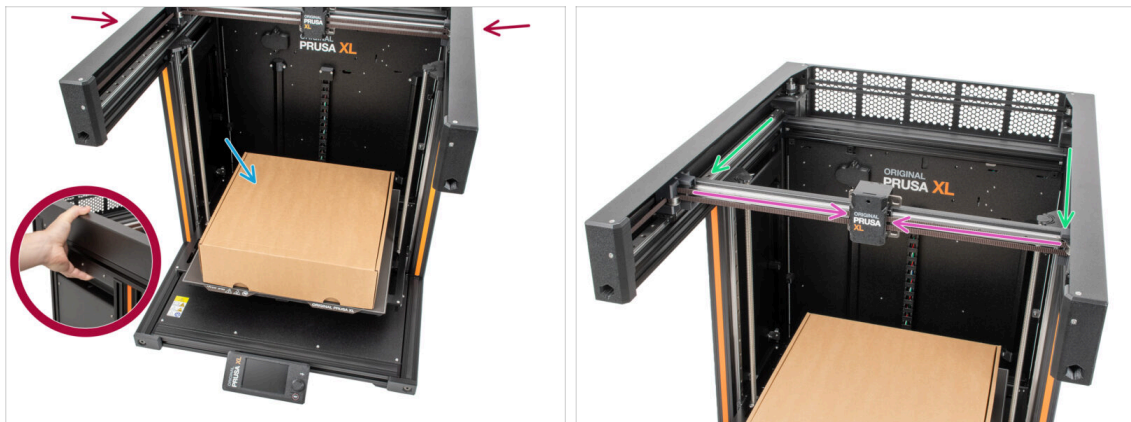

- ◆ Reminder: To handle the printer, **always grab the handles on both sides of the printer**. Do not lift the printer by the aluminum extrusions or the metal sheet profiles on top.
  - ⓘ In the following steps, we will work with tools and install the extruder above the heatbed. Protect the print surface against any possible damage. An empty Nextruder box can serve this purpose.
- ◆ Place the empty cardboard box approximately to the front center part of the heatbed.
- ◆ Manually move the X-axis assembly all the way to the front of the printer.
- ◆ Manually move the X-carriage approximately to the center of the X-axis.

## STEP 9 Nextruder cable: parts preparation



**i** From April 2025, you may receive a new cable bundle. The difference is described before the cable bundle is connected to the Nextruder.

**◆** For the Nextruder cable bundle assembly please prepare:

- ◆** Cable bundle (5x)

## STEP 10 Nozzle seal versions

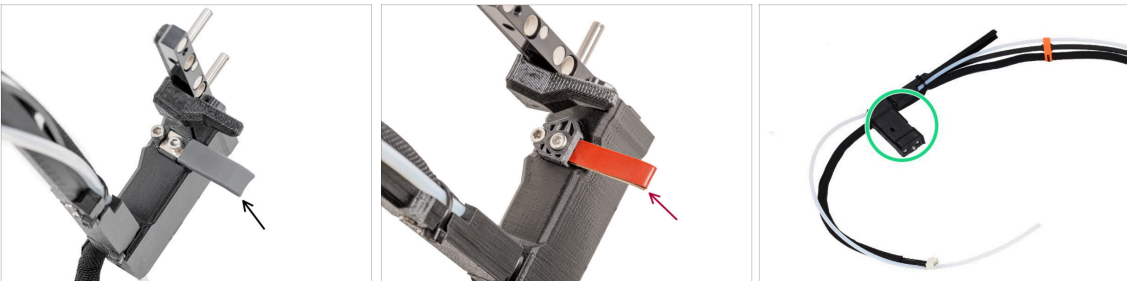

**i** The latest assemblies come with the nozzle seal pre-installed on the extruder dock.

**◆** Examine one of the extruder docks closely and compare it to the picture to see if the nozzle seal is already in place with the square nut.

**⚠** **The nozzle seals that are already pre-installed on the extruder docks might differ in color. This does not affect the assembly process.**

**◆** Grey nozzle seal.

**◆** Red nozzle seal.

**i** **If you have the pre-installed nozzle seal, continue to this step: Guiding the nextruder cable**

**◆** If your nextruder **does not have** the pre-installed nozzle seal, continue to the next step →

## STEP 11 Nozzle seal not pre-installed: nextruder dock preparation



● **Repeat this step for all tool heads:**

● Insert the M3nS nut into the nextruder dock.

● Make sure the nut is pushed into the dock all the way. If not, use the Allen key to push the nut into the nextruder dock.

ⓘ If the nut fell out during transport, look for it in the nextruder box. There is also a spare one in the nozzle seal assembly package if needed.

⚠ **Do not install the nozzle seal yet! This will be done later. We need to attach the extruder dock to the printer first.**  
Continue to the next step.

## STEP 12 Guiding the nextruder cable

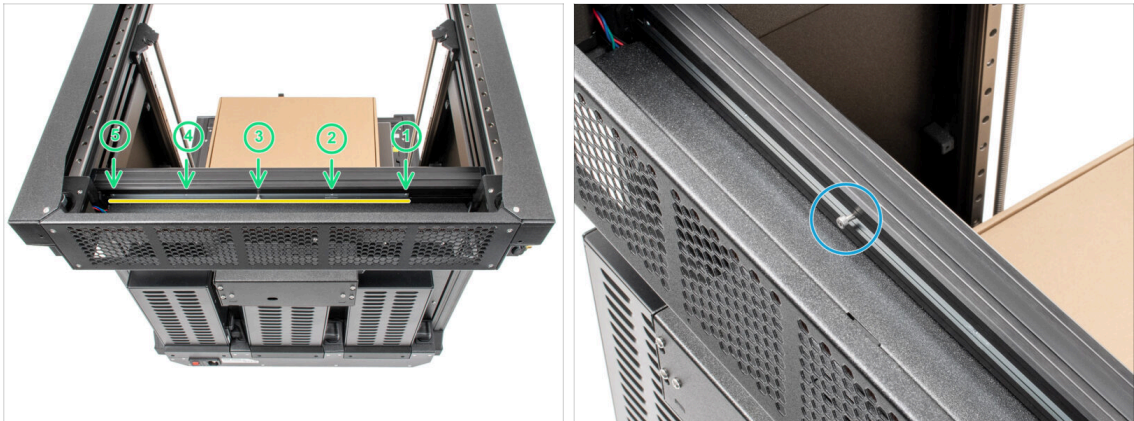

- Carefully rotate the printer 180° so that the PSU (Power Supply Unit) side is facing you.
  - Locate the long metal profile with five M3 holes inside the rear aluminum extrusion.
  - We will use all M3 holes in the metal profile.
  - Locate a screw in the long metal profile which is fixing the part during transport. **Keep the screw in the metal profile for now.**
- ⚠ **Maintain the position of the long metal profile for the next step. It must not move!** If the metal profile moves, then push it all the way to the left and fix it in position with the screw.

## STEP 13 Attaching the first and second nextruder dock

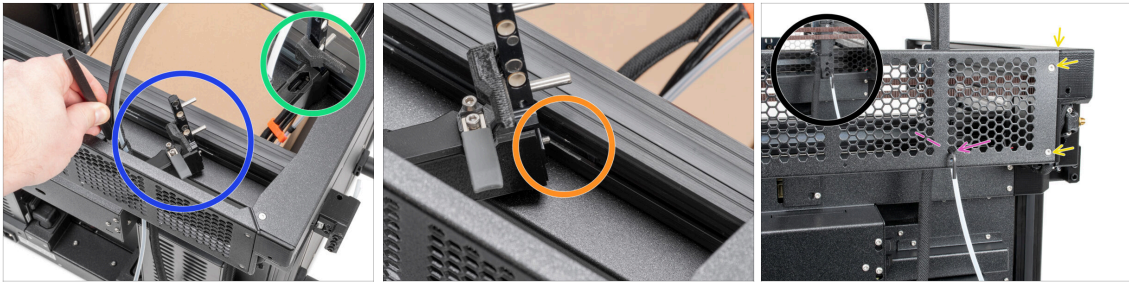

- ◆ **If your nextruder dock does not have the pre-installed nozzle seal, DO NOT install it yet!** Attach the dock as instructed in this step, and we will install the nozzle seals after the dock inspection.
- ◆ Place the xl-dock-cable-router on the bottom metal sheet below the aluminum extrusion on the right side of the printer.
- ◆ Locate the protruding screw from the XL-dock-cable-router. Attach the screw to the first M3 hole in the long metal profile (tch-mounting-insert). Check through the hole in the rear if the cable holder is lined up with the hole.
- ◆ Push the 2.5 mm Allen key all the way through the hole in the rear metal sheet until you reach the **middle** screw in the xl-dock-cable-router and tighten the screw.
- ◆ **The dock is a press fit; the screw must be tightened firmly.**
- i Repeat this step for the second tool head.

## STEP 14 Dock inspection

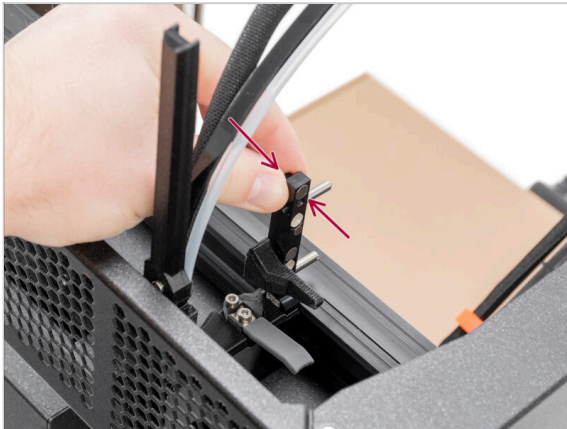

- i This step is the same for all versions of the dock assembly.
- ⚠ Check that the dock is properly tightened. **The dock must not move.**
- ⚠ The dock is a press fit, the screw must be tightened firmly.
- ◆ Please watch the video in the next step for a better understanding.

## STEP 15 Dock inspection: video

- i This step is the same for all versions of the dock assembly.
- ◆ The following instructions need to be done correctly and carefully. Achieve better understanding and successful assembly by watching the video alongside the guide.

## STEP 16 Third dock: removing the screw



- ⓘ This step is the same for all versions of the dock assembly.
- ⓘ At this point you should have already installed two docks.
- 🟢 Locate the M3 screw in the metal insert.
- 🟠 Using a 2.5mm Allen key, remove the screw from the metal insert.
- ⬛ Attach the third, fourth, and fifth docks the same way as the first two docks.
- ⓘ The dock is a press-fit, so the screw needs to be tightened firmly.
- 🟡 The attached docks have to look like in the picture
- ⓘ **If your nextruder docks HAVE THE PRE-INSTALLED NOZZLE SEALS, skip to this step: Reward yourself**
- ⓘ **If your nextruder docks DO NOT HAVE THE PRE-INSTALLED NOZZLE SEALS, continue to the next step →**

## STEP 17 Nozzle seal not pre-installed: parts preparation

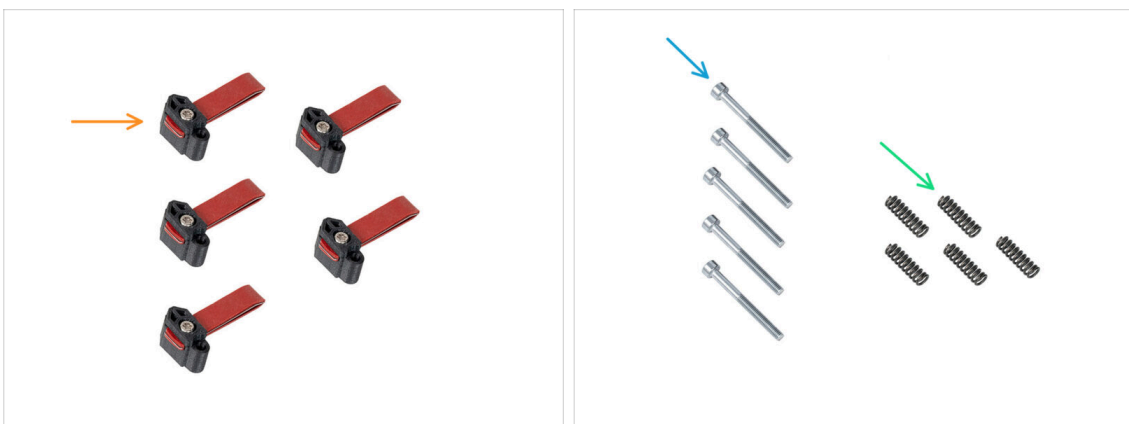

- ⬛ **The following instructions are intended only for printers without pre-installed nozzle seals.** If your printer came with the nozzle seals installed on the Nextuder docks, go to this step: **Wi-Fi antenna holder versions.**
- ⬛ **For the following steps, please prepare:**
  - 🟠 Nozzle seal (5x)
  - 🟡 M3x30 screw (5x)
  - 🟢 Spring 15x5 (5x)

## STEP 18 Nozzle seal not pre-installed: assembly

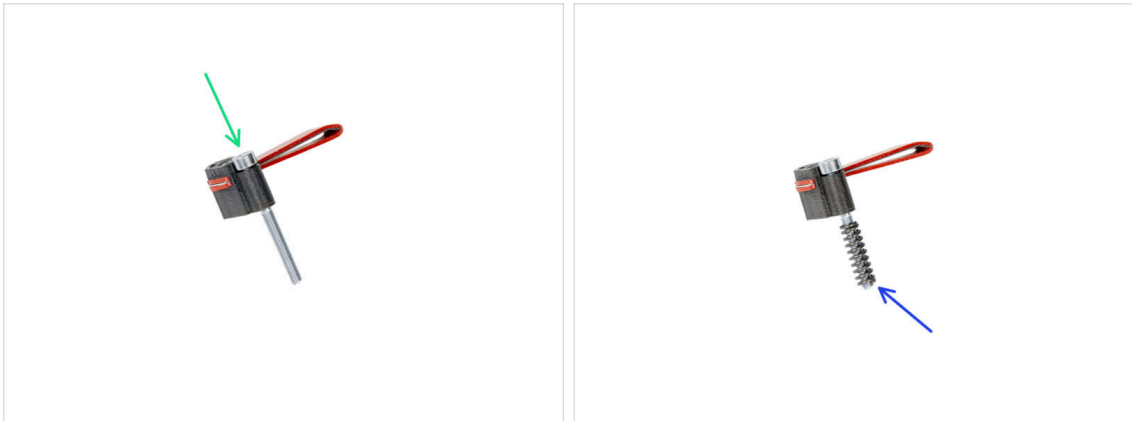

🟢 Insert the M3x30 screw into each nozzle seal.

🟡 Slide the spring on each nozzle seal.

📌 **Do this for all five nozzle seals.**

## STEP 19 Nozzle seal not pre-installed: installation



📌 **The current nozzle seal position is temporary, the exact height will be set in the next chapter once all the Nextruder parts are mounted.**

🔴 Locate the hole for a nozzle seal on the dock.

🟡 Insert the nozzle seal (with the spring) into the dock.

🟡 Using a 2.5 mm Allen key, tighten the screw so that the head of the screw is 1 mm above the dock.

⬛ Good! The first dock is ready.

🟢 Repeat this procedure for all remaining docks.

## STEP 20 Reward yourself

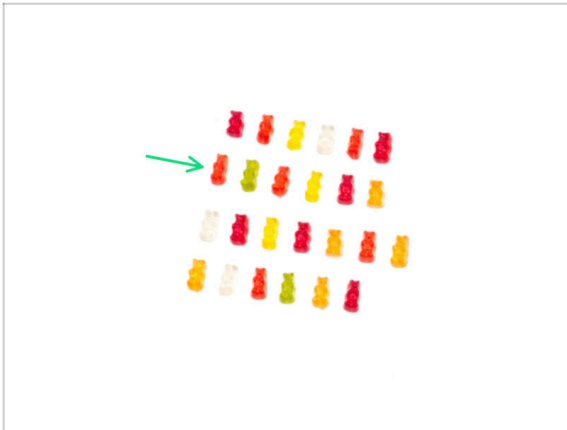

- ◆ Well done! You deserve a reward before we get to install other components.
- ◆ Eat the second row: six gummy bears.
- ⓘ Did you know that some gummy bear manufacturers offer sugar-free versions of the candy? These are sweetened with artificial sweeteners like maltitol or stevia.

## STEP 21 Wi-Fi antenna holder versions

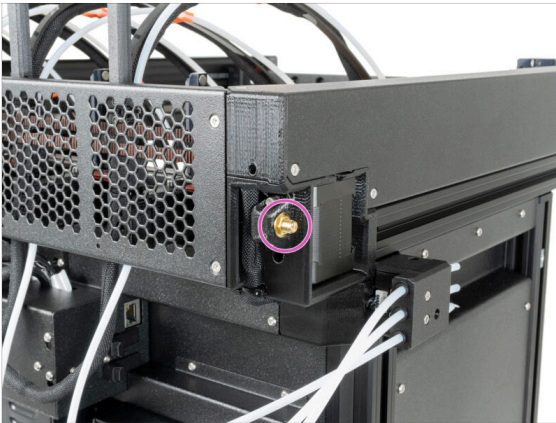

- ◆ Let's connect the Wi-Fi antenna now. There are two versions of this component. Identify which version of the Wi-Fi antenna your printer has.
- ◆ **Side version:** The antenna connector is prepared by the manufacturer, and the Wi-fi antenna holder is on the side.
- ⓘ **If you have the side version, continue to the next step in the guide: Side version: Connecting the nextruder cables.**
- ◆ **Back version:** The antenna connector has to be assembled, and the Wi-fi antenna will be mounted in the middle of the rear side of the printer.
- ⓘ **If you have the back version, skip to this step: Back version: Wi-Fi antenna holder: parts preparation**

## STEP 22 Side version: Connecting the nextruder cables

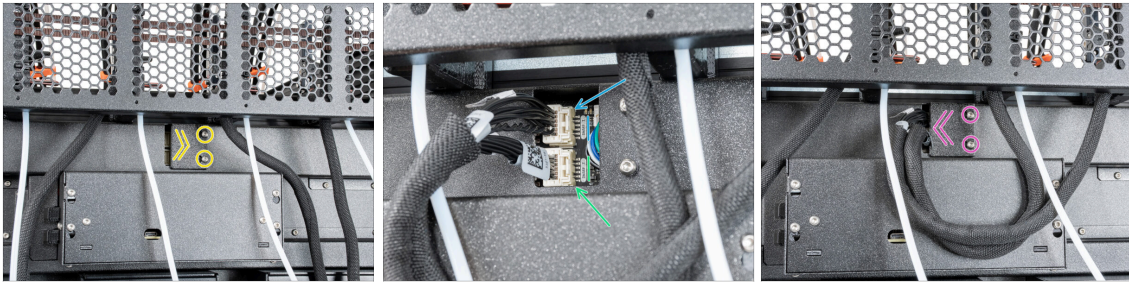

- Locate the xl-rear-cable-management-plug (cover) on the rear of the printer.
- Slightly loosen two screws on the cover. No need to remove them completely. Slide the cover to the right and remove it from the printer.
- Connect the first dock (from the right side) cable to the upper slot labeled DWARF 1.
- Connect the second dock (from the right side) cable to the lower slot labeled DWARF 2.
- Attach the connectors cover to the screws. Slide it to the left and tighten the screws. Make sure that the cables are not pinched or damaged
- ⓘ In case you bought the XL printer along with the XL enclosure, please check the XL enclosure instructions to see how this step will be modified.

## STEP 23 Side version: Removing the XL buddy box cover

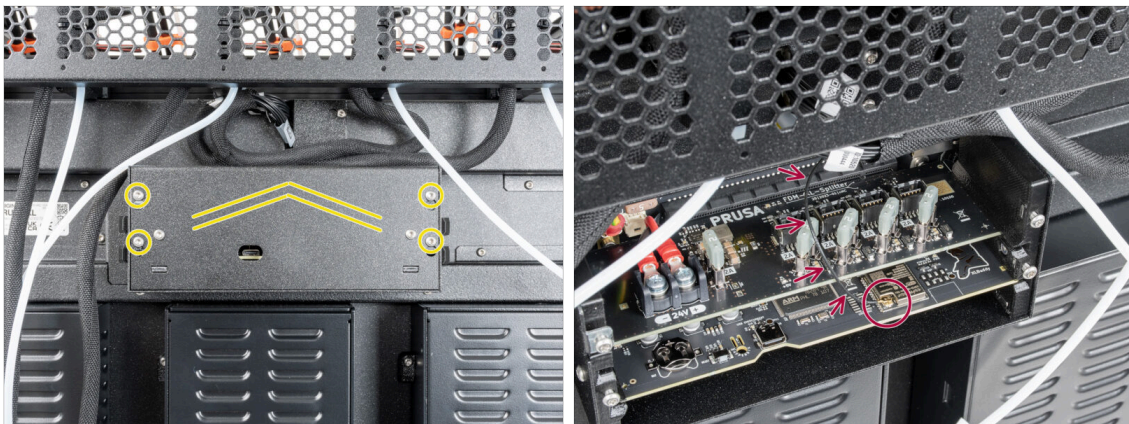

- Loosen four screws on the cover slightly. No need to remove them completely. Push the cover up and remove it from the printer.
- Don't pinch the **antenna cable** while connecting the Nextruders cables!

## STEP 24 Side version: Connecting the Nextruder cables

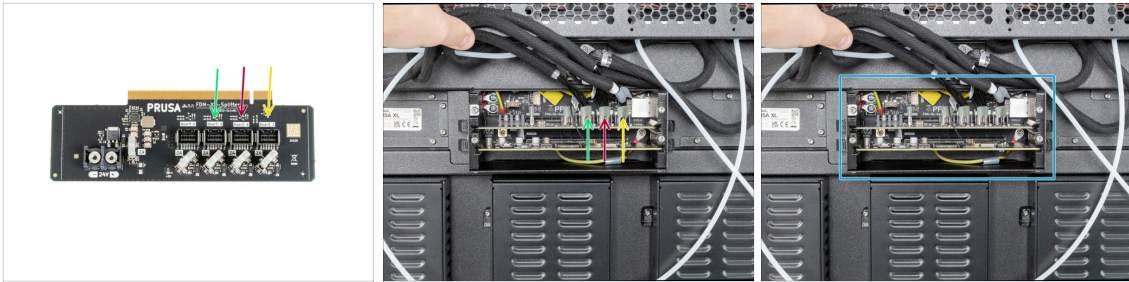

**⚠ Do not take the XL-Splitter board out of the printer, the photo is only an illustration of the connector locations.**

**📌** When connecting the cables into the Buddy board, support the board with your fingers from below to prevent bending the board.

- Connect the **third, fourth and fifth** (from the right) Nextruder to the XL-Splitter:
  - Third Nextruder.
  - Fourth Nextruder.
  - Fifth Nextruder.
- XL-splitter with connected Nextruders should look like this.

## STEP 25 Side version: Covering the XL buddy box



**⚠ Be carefull, do not pinch any cables!**

- Put the XL buddy box cover back on the printer.
- Check Nextruder cables, they have to be inside the cutout in the cover.
- With a T10 key tighten the four screws.

## STEP 26 Side version: Guiding the PTFE tubes



- 🔴 Locate the side filament sensor.
- 🟢 Insert the PTFE tube from the first dock (from the right side) all the way into the top hole in the filament sensor.
- 🟡 Insert the PTFE tube from the second dock (from the right side) all the way into the middle hole in the filament sensor.
- 🟣 Insert the PTFE tube from the third dock (from the right side) all the way into the bottom hole in the filament sensor.

## STEP 27 Side version: Guiding the PTFE tubes, part 2



- 🔴 Locate the left filament sensor.
- 🟡 Insert the fourth dock (from the right side) PTFE tube all the way into the top hole in the filament sensor.
- 🟣 Insert the fifth dock (from the right side) PTFE tube all the way into the middle hole in the filament sensor.

## STEP 28 Side version: Installing the Wi-Fi antenna: parts preparation



- ◆ For the following steps, please prepare:
- ◆ Wi-Fi antenna (1x)
- ⓘ The Original Prusa XL is shipped with two versions of the Wi-Fi antenna, each with a different shape. The functionality is the same.

## STEP 29 Side version: Installing the Wi-Fi antenna

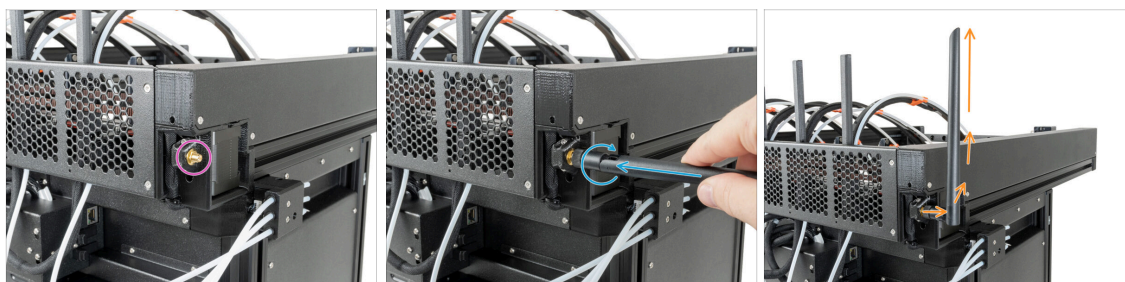

- ◆ Locate the Wi-Fi antenna connector on the right rear corner of the printer.
- ◆ The antenna can be rotated around and bent in two directions.
- ◆ We recommend pointing the antenna straight upwards.
- ⓘ Once the Wi-Fi antenna is installed, skip to this step: **Spoolholder assembly versions**

### STEP 30 Back version: Wi-Fi antenna holder: parts preparation



● For the following steps, please prepare:

- Wi-Fi-antenna-holder version E3/E4 (1x)
- Antenna cable (1x)

### STEP 31 Back version: Installing the Wi-Fi antenna: antenna preparing

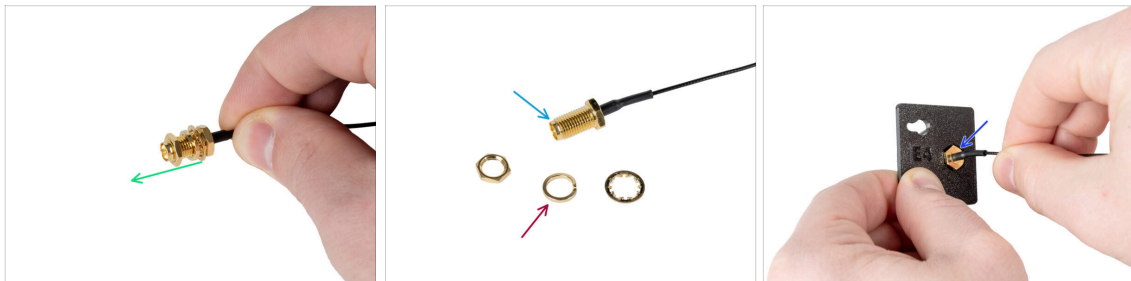

- Remove the nut with the washers from the antenna connector.
- The antenna connector is prepared.
- The latest version of the connector has a thicker washer. We do not need it anymore. You can throw it away.
- Insert the antenna connector into the same-shaped hole in the Wi-Fi-antenna-holder .

### STEP 32 Back version: Installing the Wi-Fi antenna: antenna preparing

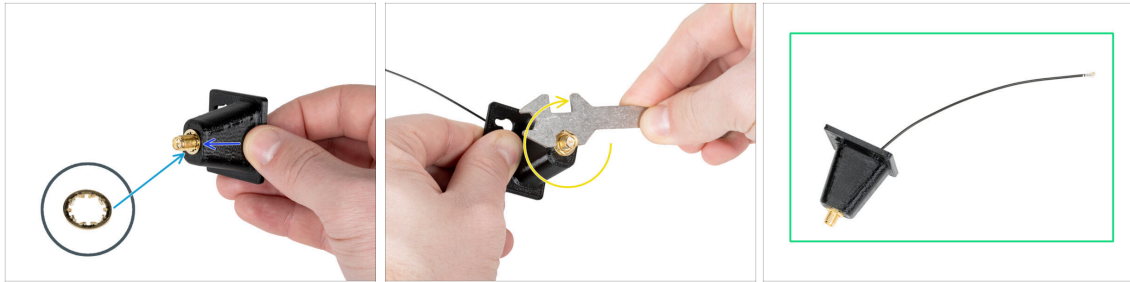

- Push the antenna connector through the Wi-Fi-antenna-holder.
- Insert the thinner washer back onto the connector.
- Using the universal wrench, tighten the nut on an antenna connector.
- Good job! The Wi-Fi antenna is prepared.

### STEP 33 Back version: Connecting the nextruder cables

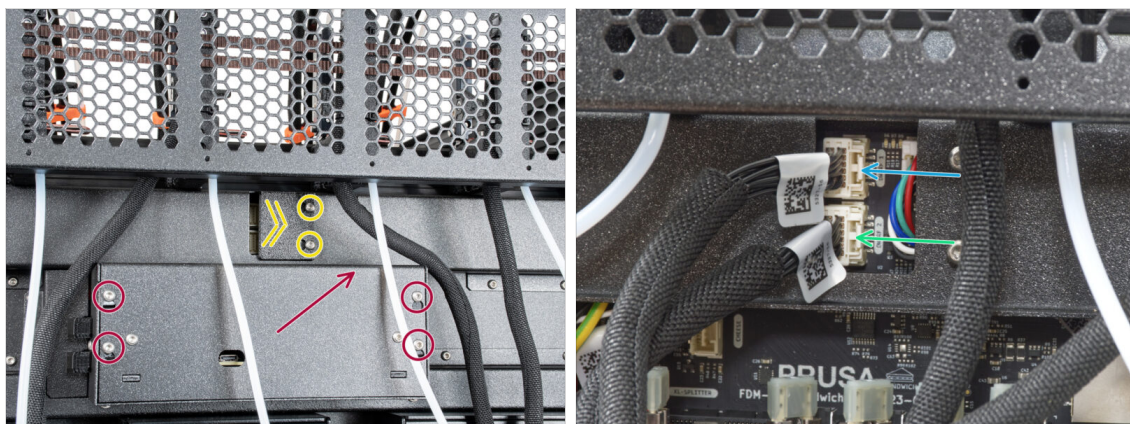

- Locate the xl-rear-cable-management-plug (cover) on the rear of the printer.
- Loosen two screws on the cover slightly. No need to remove them completely. Push the cover to the right and remove it from the printer.
- Loosen four screws securing the electronics cover. Remove the cover.
- Connect the first dock (from the right side) cable to the upper slot labeled DWARF 1.
- Connect the second dock (from the right side) cable to the lower slot labeled DWARF 2.

## STEP 34 Back version: Installing the Wi-Fi antenna holder

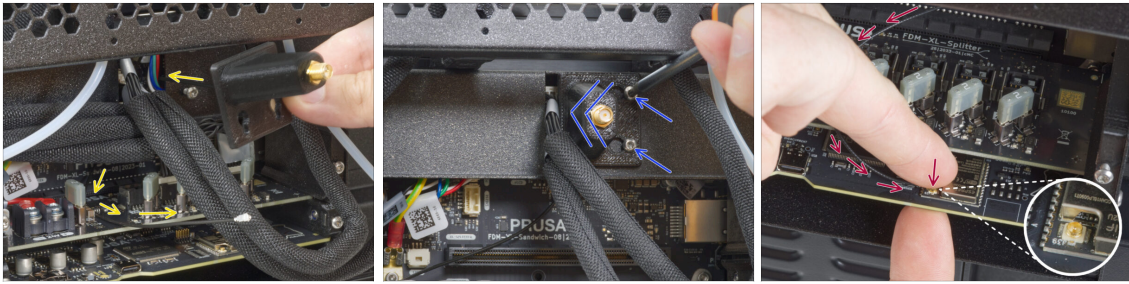

- ◆ Push the antenna cable through the opening in the cable cover (metal sheet) and guide it behind the cover to the electronics box.
- ◆ Attach the antenna-holder on the screws, slide the cover to the left, and tighten the screws.
- ◆ Gently, but firmly, connect the antenna cable with the antenna connector on the XL buddy board.
- i Support the board from below with your finger while attaching the antenna cable to prevent damaging the board.

## STEP 35 Back version: Connecting the Nextruder cables

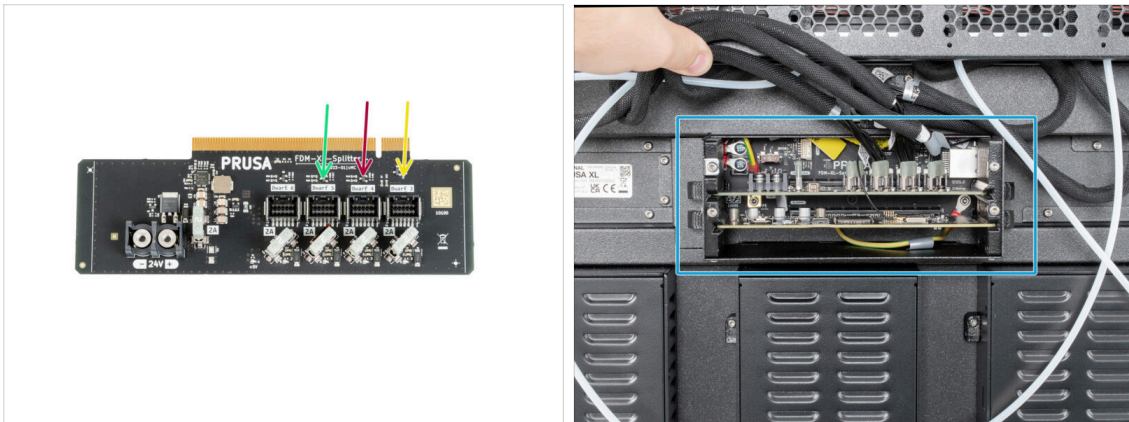

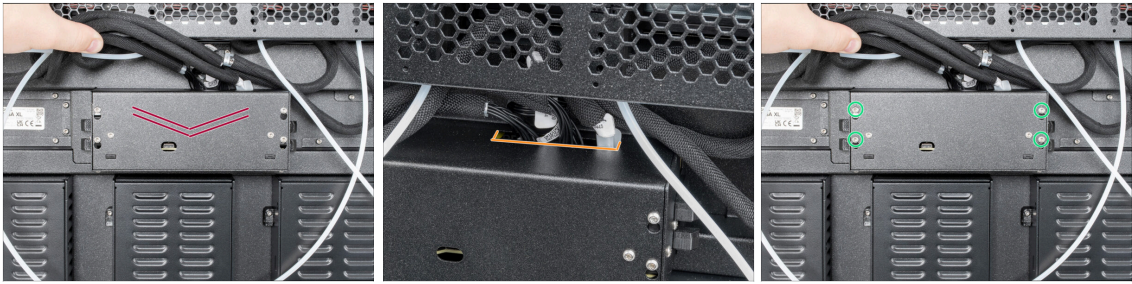

- i **Do not take the XL-splitter board out of the printer.** The photo has just the splitter board to show you where to connect the nextruder cables.
- ◆ Connect the third, fourth and fifth (from the right) Nextruder to the splitter:
  - ◆ Third Nextruder.
  - ◆ Fourth Nextruder.
  - ◆ Fifth Nextruder.
- ◆ XL-splitter with connected Nextruders has to look like this.

### STEP 36 Back version: XL buddy box covering







 **Be carefull, do not pinch any cables!**

-  Put the XL-buddy-box-cover back on the printer.
-  Check Nextruders cables, they have to be inside the cutout in the cover.
-  With a T10 key tighten the four screws.

### STEP 37 Back version: Guiding the PTFE tubes



-  Locate the right filament sensor.
-  Insert the first dock (from the right side) PTFE tube all the way into the upper hole in the part.
-  Insert the second dock (from the right side) PTFE tube all the way into the middle hole in the filament sensor.
-  Insert the third dock (from the right side) PTFE tube all the way into the bottom hole in the filament sensor.

## STEP 38 Back version: Guiding the PTFE tubes, part 2

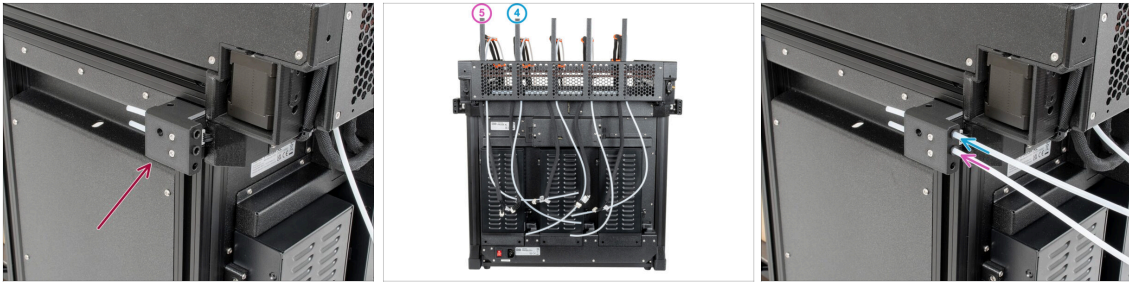

- ◆ Locate the left filament sensor.
- ◆ Insert the PTFE tube from the **fourth** dock (from the right side) all the way into the upper hole in the part.
- ◆ Insert the PTFE tube from the **fifth** dock (from the right side) all the way into the middle hole in the part.

## STEP 39 Back version: Installing the Wi-Fi antenna: parts preparation



- ◆ For the following steps, please prepare:
- ◆ Wi-Fi antenna (1x)
  - ⓘ The Original Prusa XL is shipped with two versions of the Wi-Fi antenna, each with a different shape. The functionality is the same.

## STEP 40 Back version: Installing the Wi-Fi antenna

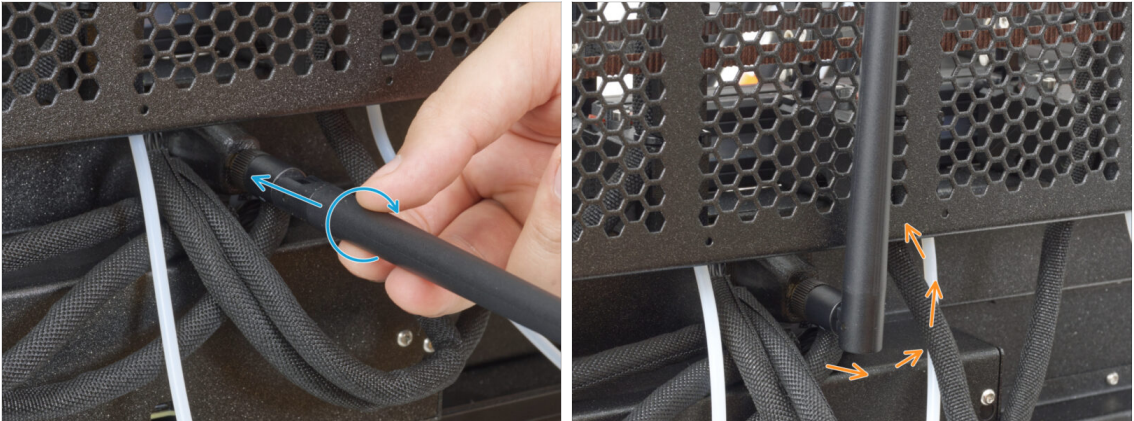

- ◆ Locate the Wi-Fi antenna connector in the middle of the printer.
- ◆ Screw the Wi-Fi antenna on the antenna connector. The antenna can be rotated around and bent in two directions.
- ◆ We recommend pointing the antenna straight upwards.
- ◆ Well done, the Wi-Fi antenna is installed, let's move on to the spool holders.

## STEP 41 Spool holder assembly versions



- ① **Original Prusa XL comes with two versions of the spool holder.** Each version has slightly different parts and procedures.
- ◆ Refer to the pictures to compare which parts you have, and then choose the instructions that match:
  - ◆ **Printed spool holder:** Set of three printed parts. If you have this version, continue to the **Printed spool holder: parts preparation.**
  - ◆ **Injection molded spool holder:** Set of two injection molded parts. If you have this version, continue to **Version B: Injection molded spool holder: parts preparation..**

## STEP 42 Printed spool holder: parts preparation



● For the following steps, please prepare:

- Spool-holder-slider (5x)
- Spool-holder-base (5x)
- Spool-holder-mount (5x)
- M5x85 screw (5x)
- M5nEs nut (5x)

## STEP 43 Printed spool holder: left side



- Carefully turn the printer so that the side with the Wi-Fi antenna faces you.
- Insert the M5nEs nut into the front support extrusion (with the orange plastic cover). Insert the side with the spring (metal plate) first, then push the nut inside.
- The M5nEs nut is free to move, you can adjust the position as you want. But remember, the nut must be slightly pushed in to smoothly move. Anyway, we recommend approximately the same position as you can see in the picture.
- Insert **second** and **third** M5nEs nut in the extrusion approximately to the same position as shown.

## STEP 44 Printed spool holder: Assembly



### Repeat this step for all five spool holders:

- Insert the spool-holder-base into the spool-holder-slider and push it through a little through the part.
- Attach the spool-holder to the spool-holder-mount.
- Insert the M5x85 screw into the spool-holder-assembly.

## STEP 45 Printed spool holder: Mounting the assembly

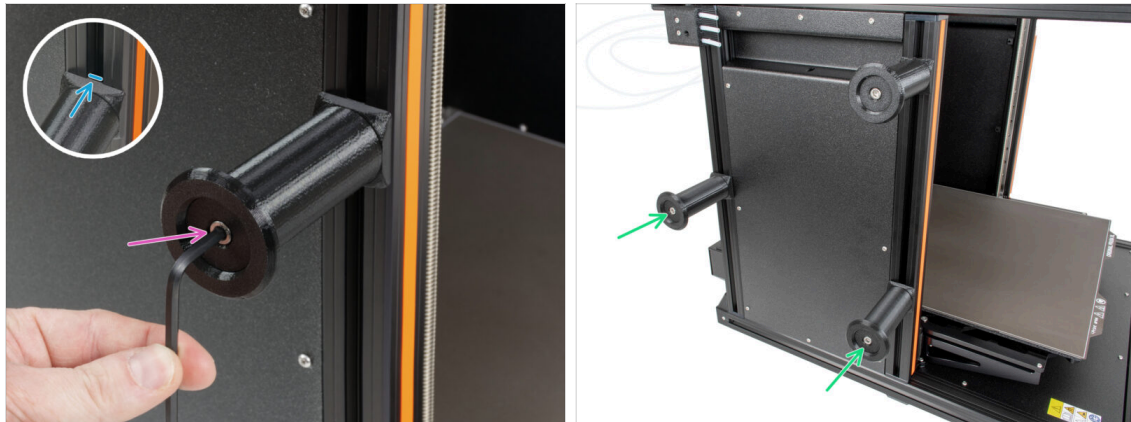

- Attach the spool holder assembly to the M5nEs nut in the extrusion. Note that there is a protrusion on the spool-holder-mount, which must fit into the groove in the extrusion.
  - Tighten the spool holder assembly with a 4 mm Allen key.
  - Attach and tighten the second and the third spool holder to the M5nEs nut using a 4 mm Allen key.
- ⚠ Do not use the spool holder as a handle when moving the printer!**
- i** Keep in mind that if you mount the Spool holder too high or too low, it may not fit the filament spool on it. There has to be enough space around it.

## STEP 46 Printed spool holder: right side assembly

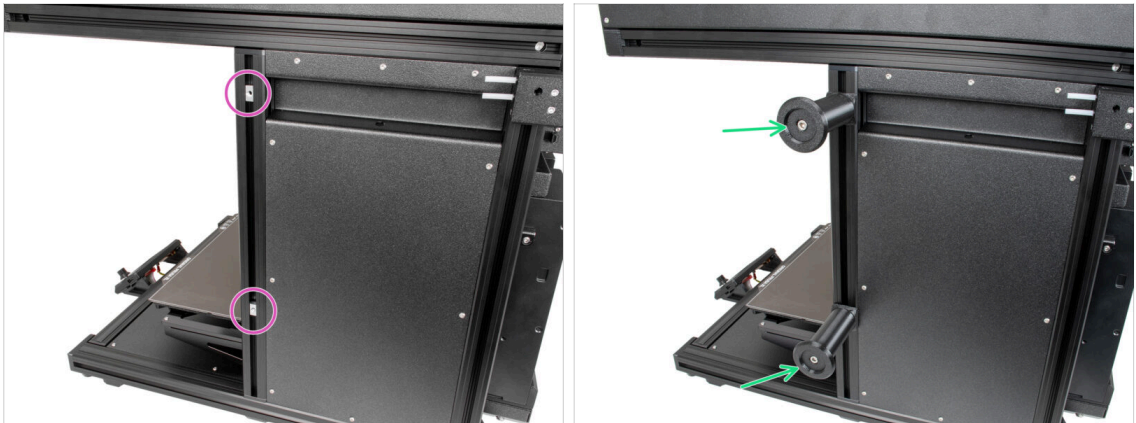

- Carefully turn the printer so that the side without the Wi-Fi antenna faces you.
- Insert the fourth and fifth M5nEs nut in the extrusion approximately to the same position as shown.
- Attach and tighten the fourth and the fifth spool holder to the M5nEs nut using a 4 mm Allen key.
- ⚠ **Do not use the spool holder as a handle when moving the printer!**
- ⓘ Keep in mind that if you mount the Spool holder too high or too low, it may not fit the filament spool on it properly. There has to be enough space around.
- Now, go to **Nextruder assembly: parts preparation**.

## STEP 47 Injection molded spool holder: parts preparation



- For the following steps, please prepare:
- Spool-holder-slider 5x)
- Spool-holder-base (5x)
- M4x12 screw (5x)
- M4nEs nut (5x)

## STEP 48 Injection molded spool holder: adjusting the nut



- Carefully turn the printer so that the side with the Filament sensor (with 3 PTFE tubes) is facing you.
- Insert the first M4nEs nut into the front support extrusion (with the orange plastic cover). Insert the side with the spring (metal plate) first, then push the nut inside.
- Insert the second and the third M4nEs nut into the extrusions as described in the picture.
- The M4nEs nuts are free to move; you can adjust the position as you want. The nuts must be slightly pushed in to smoothly move. Refer to the image to see the ideal position.

## STEP 49 Injection molded spool holder: Assembly

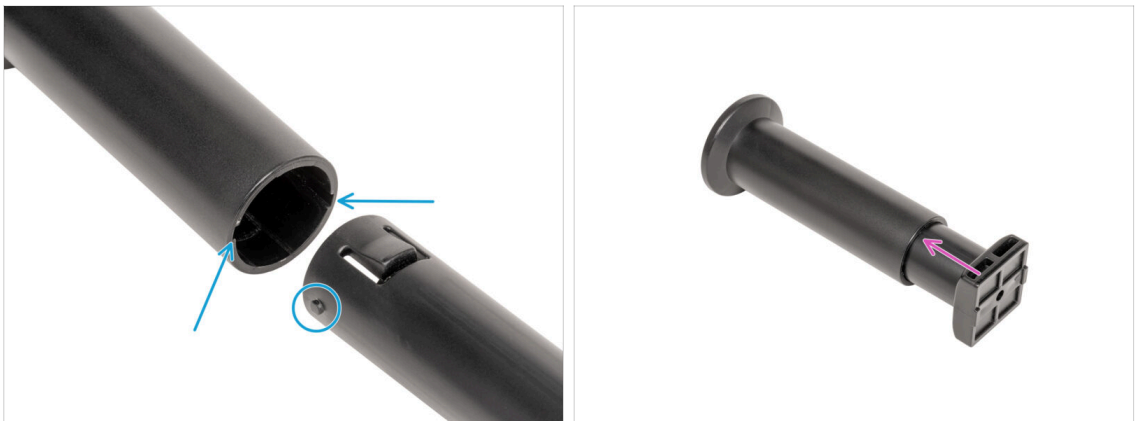

- Locate pins two pins on the spool-holder-base and line them with the rails in the spool-holder-slider.
- Insert the spool-holder-base into the spool-holder-slider and push it through a little through the part.

## STEP 50 Injection molded spool holder: Preparation



- Insert the M4x12 screw on the longer side of the 3mm Allen key.
- Insert the 3mm Allen key with the M4x12 screw through the assembled spool holder to the prepared hole in the spool-holder-base.
- The M4x12 screw has to protrude through the spool-holder-base.

## STEP 51 Injection molded spool holder: left side assembly

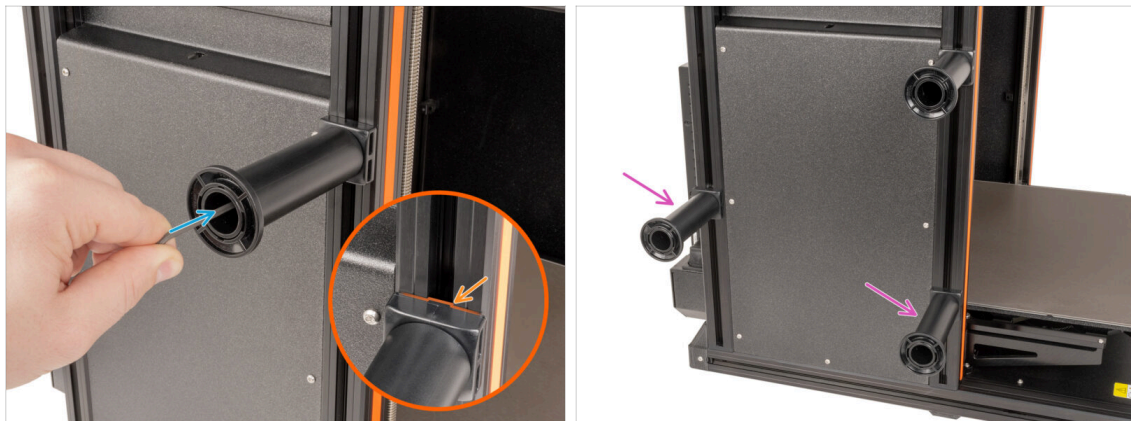

- Attach the first spool holder assembly to the M4nEs nut in the extrusion. Note that there is a protrusion on the spool-holder-base, which must fit into the groove in the extrusion.
- Tighten the spool holder assembly.
- Assemble the second and the third spool holder and attach them to the M4nEs nuts with M4x12 screws.

**⚠ Do not use the spool holder as a handle to lift or move the printer!**

## STEP 52 Injection molded spool holder: right side assembly



- Turn the printer, so the Filament sensor (with two PTFE tubes) is facing you.
- Insert the fourth and fifth M4nEs nut in the extrusion approximately to the same position as shown.
- Attach and tighten the fourth and the fifth spool holder to the M4nEs nut using a 3 mm Allen key.
- ⚠ **Do not use the spool holder as a handle to lift or move the printer!**
- ⓘ Keep in mind that if you mount the Spool holder too high or too low, it may not fit the filament spool on it. There has to be enough space around it.
- Well done! With the spoolholders mounted, we can move on to assemble the nexttruders →

## STEP 53 Nexttruder assembly: parts preparation

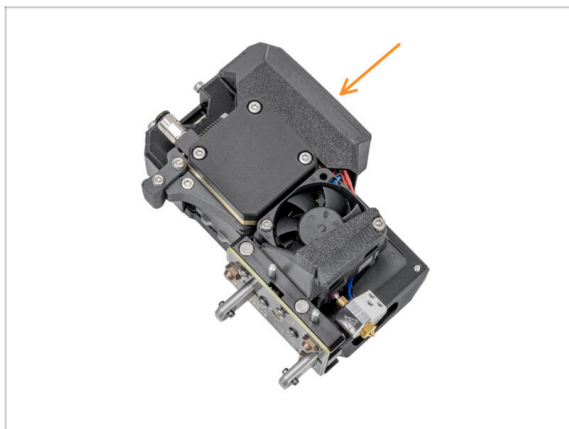

- ⓘ Starting in April 2025, you may receive a new nexttruder. The difference is described before the cable bundle is connected to the nexttruder.
- For the next steps, please prepare:
  - Nexttruder (5x)

## STEP 54 Docking the Nextruder

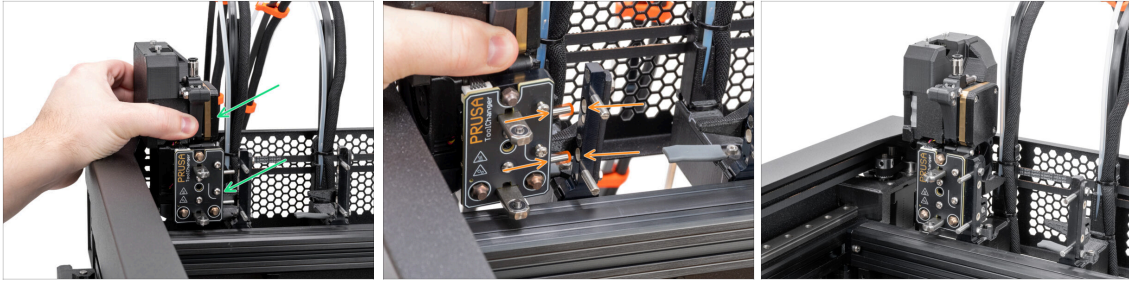

- Take the Nextruder and place it carefully next to the dock.
- Place the two metal inserts through the white holes in the dock. The magnets will help you dock the Nextruder.
- Well done, the first Nextruder is ready!
- Dock the **second, third, fourth and fifth** Nextruder in the same way as the first.

## STEP 55 Nextruder cable bundle assembly

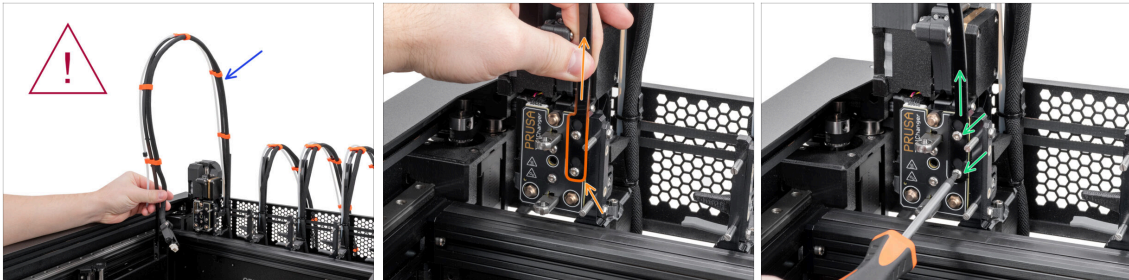

- **Repeat this step for all tool heads:**
  - Take the first Nextruder cable bundle.
  - ⚠ **Check that the cable bundle is not twisted!**
  - Loosen the two highlighted screws. Hook up the keyhole openings in the flexible plate of the cable bundle onto the screw heads and push it up to correct the position.
  - Hold the Nextruder and using a T10 Torx screwdriver tighten the two screws.

## STEP 56 Nextruder cable bundle assembly versions

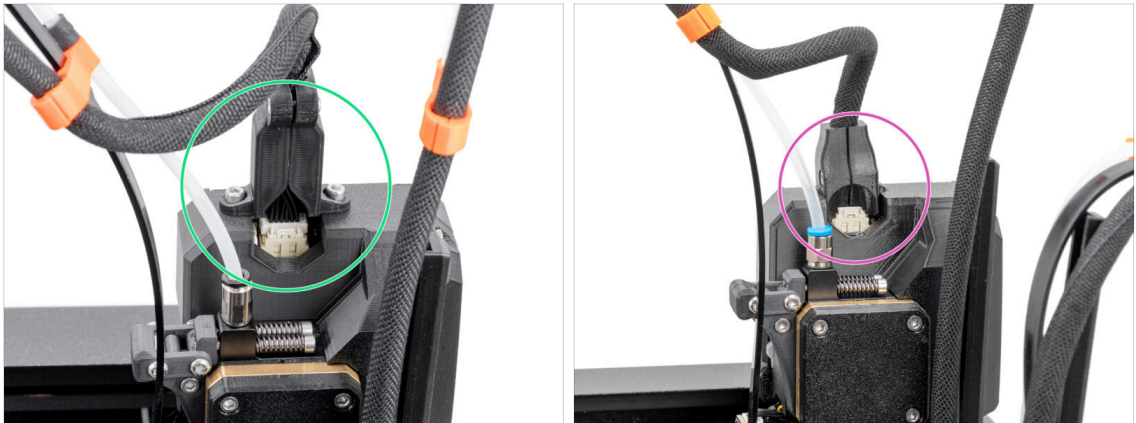

**i** Starting from April 2025, you may receive a new cable bundle.

**◆** The cable bundle connector is secured with two screws. Continue to the next step →

**⚠** **Older version:**

**◆** The cable bundle connector is secured without any screws. Continue to: **No screws version: Nextruder cable bundle assembly**

## STEP 57 Two screws version: Nextruder cable bundle assembly



**◆** Repeat this step for all tool heads:

**◆** Insert the semi-transparent PTFE tube into the fitting on the nextruder. Push it all the way in.

**◆** Remove two M3x10 screws.

**◆** Attach the cable connector to the top of the nextruder. Secure the connector with two M3x10 screws.

**◆** Assemble and connect all nextruders.

**◆** Good job, now proceed to **Reward yourself**

## STEP 58 No screws version: Nextruder cable bundle assembly



### Repeat this step for all tool heads:

- Insert the semi-transparent PTFE tube into the fitting on the Nextruder. Push it all the way in.
- Attach the cable connector into the top of the Nextruder.
- ⓘ Starting from September 2024, you may receive a new black Fitting M5-4. The assembly and functionality remain identical to the blue one.
- Assemble and connect all Nextruders.
- Good job!

## STEP 59 Reward yourself

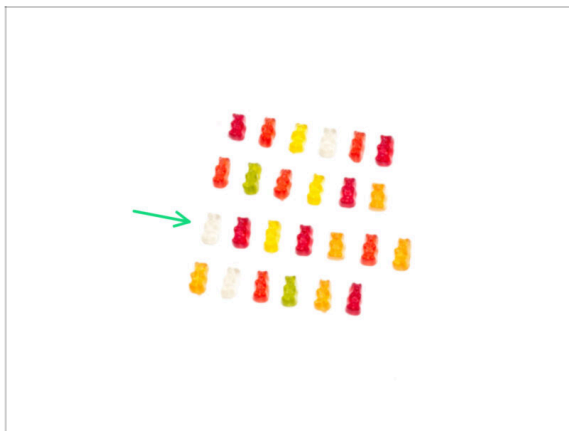

- Great job! Reward yourself with another row of gummy bears.
- Eat the third row: seven gummy bears.
- ⓘ Did you know that the bright colors of gummy bears are achieved through the use of food coloring, which adds to their visual appeal?

## STEP 60 Almost done!



- Compare the final look with the picture.
- **Congratulation!** Your Original Prusa XL is ready to be fired up!

## 4. First run



## STEP 1 Before you start with Multi-Tool



- i This chapter shows a brief description of the wizard. Please note that the screenshots are illustrative and might differ from those in the firmware.
- i Make sure you are running **Firmware 6.2.4 or newer**.
- i Some parts of the wizard must be done multiple times, this depends on the number of tool-heads. For example:
  - ◆ Dock Calibration
  - ◆ Loadcell calibration
  - ◆ Filament sensor calibration

## STEP 2 Nozzle seal height calibration

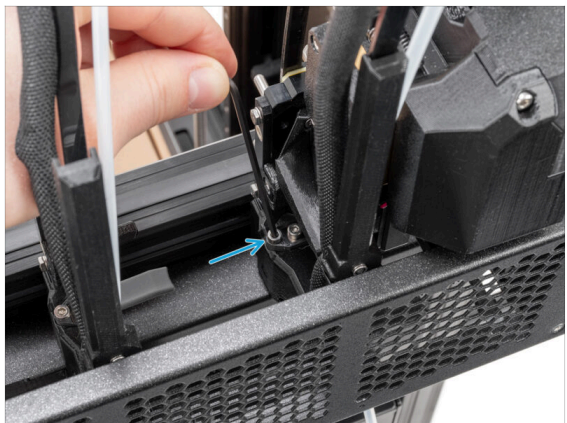

- i Starting from May 2024, you may receive a gray nozzle seal. The assembly and functionality remain identical to the red one.
  - ◆ On the Nozzle seal height calibration steps were used docked Nextruder without the printer for better visibility, proceed next steps on your printer. **Do not dismantle the docks.**
  - ◆ In the next step, we'll calibrate the height of the nozzle seal.
  - ◆ Using the 2.5 mm Allen key, tighten or untighten the M3x30 screw to calibrate the height of the nozzle seal.
  - ◆ Proceed to the next step.

### STEP 3 Nozzle seal height calibration



- If the nozzle seal is too low or too high, we need to reposition its height.
- Using a 2.5 mm Allen key, turn the M3x30 screw clockwise to set the Nozzle seal lower.
- ⓘ If you are having trouble reaching the screw, then you can detach the adjacent printhead to gain better access.
- If the Nozzle seal is not bent and it is touching the nozzle, it is in the correct position.
- ⓘ Try gently pushing on the bottom of the nozzle seal with your finger to check that the nozzle seal is touching the nozzle.

### STEP 4 Nozzle Seal Adjustment

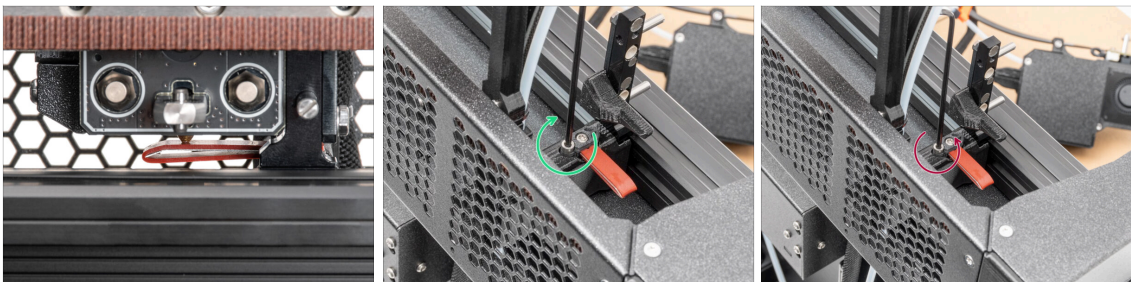

- ⚠ **This adjustment is important!** Ensure the Nozzle Seal height is set properly, or the nexttruder might drip molten filament.
- ⓘ Watch the video on how to correctly set up the Nozzle Seal
- Adjust the Nozzle seal:
  - If the Nozzle seal is too high, adjust the height by turning the screw clockwise.
  - If the Nozzle seal is too low, adjust the height by turning the screw counterclockwise.

## STEP 5 Preparing the printer



⚠ Make sure that the printer is placed in a stable place where no ambient vibrations are transmitted (for example, where other printers are printing).

- From the rear side of the printer, plug in the PSU cable.
- Turn the power switch ON (symbol "I").

## STEP 6 Firmware update

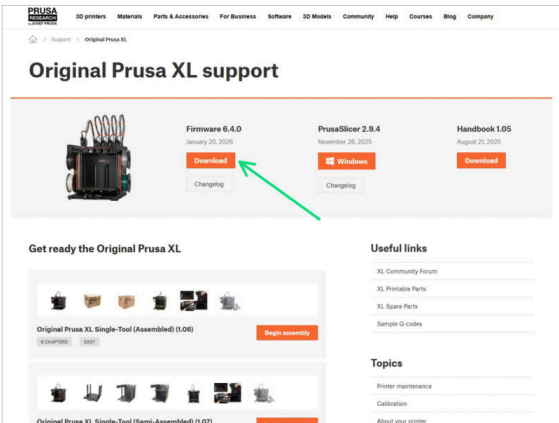
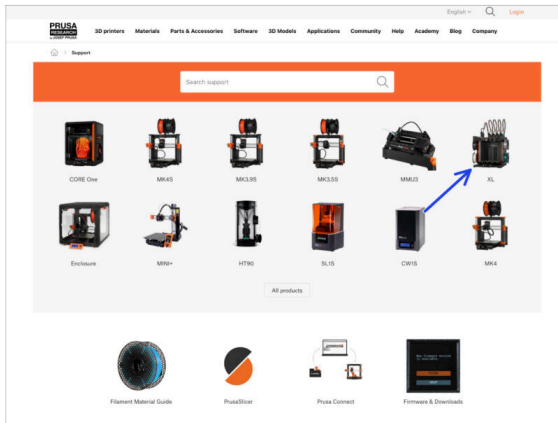

- i** All shipped printer packages include a USB drive with the latest firmware. However, it is recommended to check and possibly upgrade the firmware version.
- Visit the [help.prusa3d.com](https://help.prusa3d.com) page.
- Navigate to the Prusa XL page.
- Save the firmware file (*.bbf*) onto the bundled USB drive.
- i** Pro tip: To access Prusa XL homepage you can use the URL: [prusa.io/XL](https://prusa.io/XL)

## STEP 7 Checking the print fan type

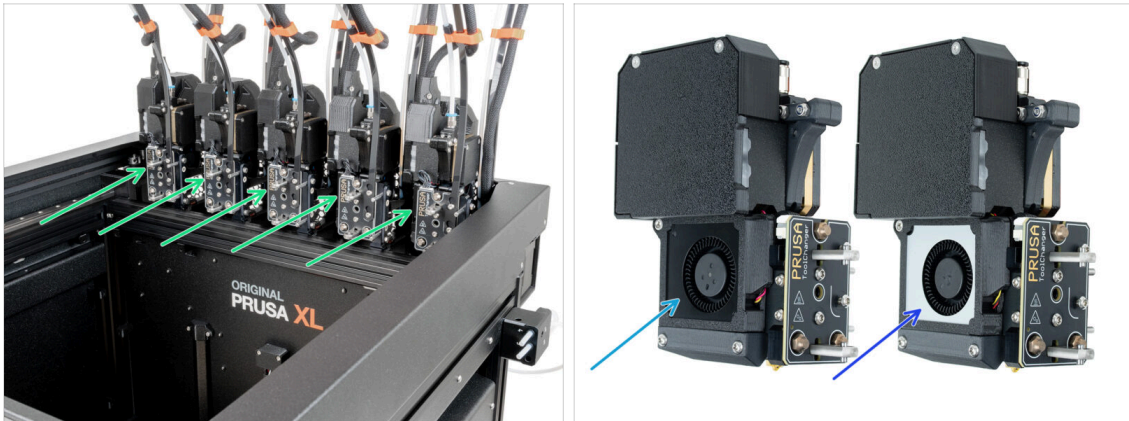

⚠ Starting January 2026, printheads are shipped with a silver print fan. Check the color of the print fan installed on the toolhead. In the following step, you will confirm the print fan type in the printer menu.

- Check the color of the print fans on the left side of each toolheads.
- Black print fan.
- Silver print fan.

## STEP 8 Setting silver print fan



- After the printer starts up, the setup wizard will show up - Printer setup.
- If all print fans are black, select **Done** using the knob to skip to the next step.
- If any print fans are silver, set them in this step:  
**Tools -> Tool 1 -> Print Fan Type -> Silver** for first toolhead,  
**Tools -> Tool 2 -> Print Fan Type -> Silver** for second toolhead,  
**Tools -> Tool 3 -> Print Fan Type -> Silver** for third toolhead,  
**Tools -> Tool 4 -> Print Fan Type -> Silver** for fourth toolhead,  
**Tools -> Tool 5 -> Print Fan Type -> Silver** for fifth toolhead.

## STEP 9 Wizard: Network and Prusa Connect setup



- i After the printer starts up, the screen prompts for the printer test and setup wizard.
  - ◆ The initial setup starts with the optional NETWORK SETUP, which also includes PRUSA CONNECT SETUP. Follow the instructions on the screen if you want your printer connected to Wi-Fi and Prusa Connect.

## STEP 10 Wizard: Calibration tests

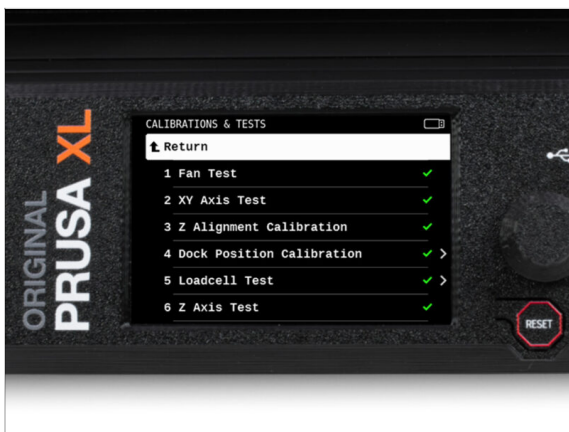

- i The wizard will test all important components of the printer. Some parts of the wizard require direct user interaction. Follow the instructions on the screen.
  - ! ⚠ **WARNING: Do not touch the printer during the wizard unless prompted! Some parts of the printer may be HOT and moving at high speed.**
  - 📌 The wizard starts with these tests:
    - ◆ Fan test
    - ◆ X-axis and Y-axis test
    - ◆ Z-axis alignment calibration
  - ◆ These first tests are fully automatic during the first calibration.
  - ! ⚠ **While testing the axes, make sure that there is nothing in the printer that is obstructing the movement of the axes.**

## STEP 11 Wizard: Dock Position Calibration

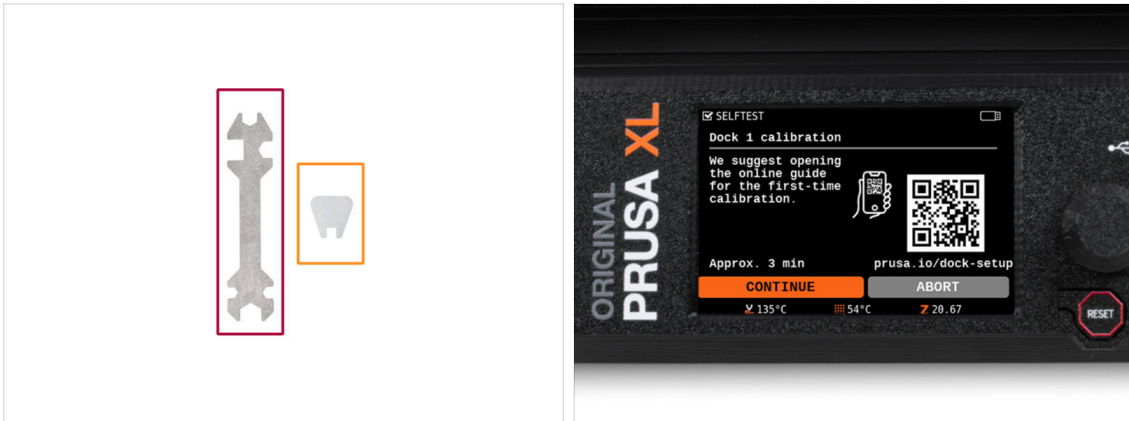

**i** This test will require your input. The printer will guide you through properly calibrating the position of individual tool heads on the printer.

● You will need:

- Universal wrench (1x)
- Mini wrench (1x)

**⚠** It is necessary to follow every step in the dock calibration properly! **Do not rush. Read every step twice, then proceed with the instruction.**

## STEP 12 Wizard: Remove the dock pins



● Follow the wizard instructions on the screen.

● Using a Mini wrench, unscrew and remove both dock pins on Dock 1. Set them aside, we will use them again soon.

## STEP 13 Wizard: Loosen screws

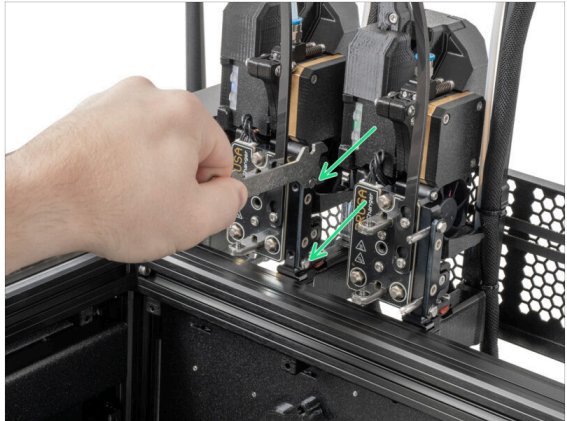

- Follow the wizard instructions on the screen.
- Using a Uni wrench, loosen two screws. **A few turns are enough; do not remove the screws.**

## STEP 14 Wizard: Lock the tool

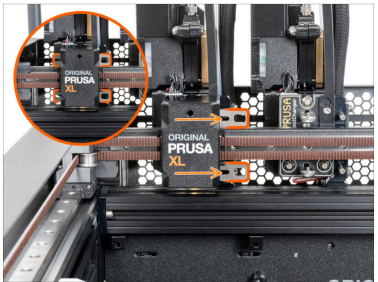
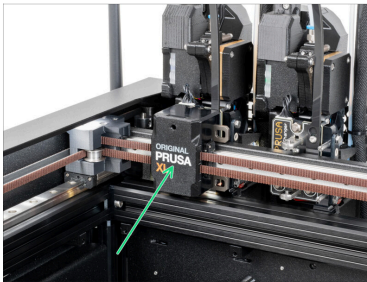

- Follow the wizard instructions on the screen.
- Slowly and carefully move the tool changing mechanism by hand to the first (leftmost) tool.
- Manually lock the metal bars as indicated in the picture.
- ⚠ **The tool has to be locked in the tool changer.**

## STEP 15 Wizard: Tighten the upper screw

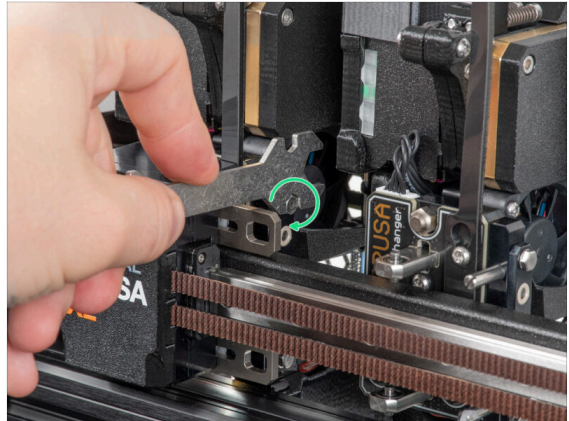

- Follow the wizard instructions on the screen.
- Using a Uni wrench, tighten the upper screw on the side of the dock.
- ⚠ After confirming by the *continue* button on the LCD, the XY axis will leave the dock with the tool. **Make sure that there are no obstacles in the way.**

## STEP 16 Wizard: Tighten the lower screw

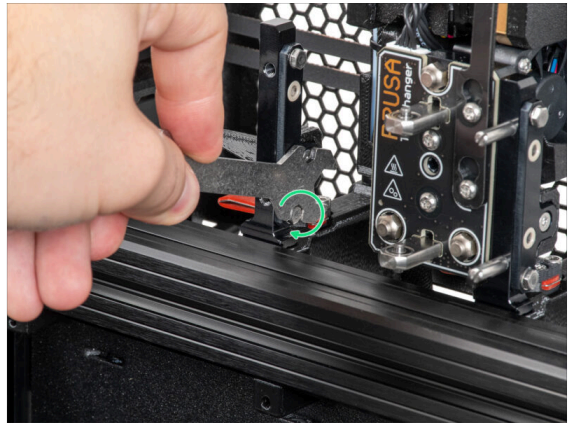

- Follow the wizard instructions on the screen.
- Using a Uni wrench, tighten the lower screw on a side of the dock.

## STEP 17 Wizard: Install the dock pins

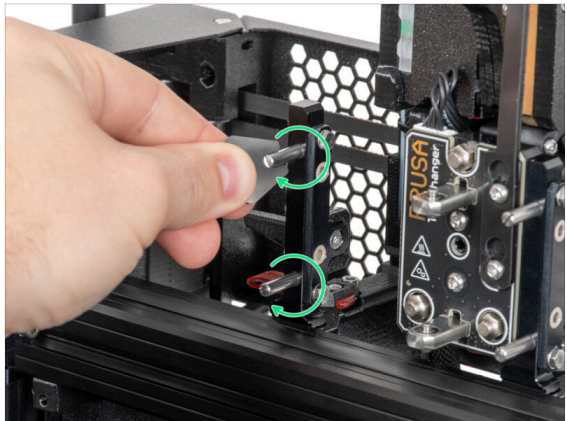

- Follow the wizard instructions on the screen.
- Insert the two metal pins and tighten them with a Mini wrench.
- After clicking on the *continue* button on the LCD, the printer will put the tool back into dock 1 and perform a few calibration moves.

## STEP 18 Wizard: Dock successfully calibrated

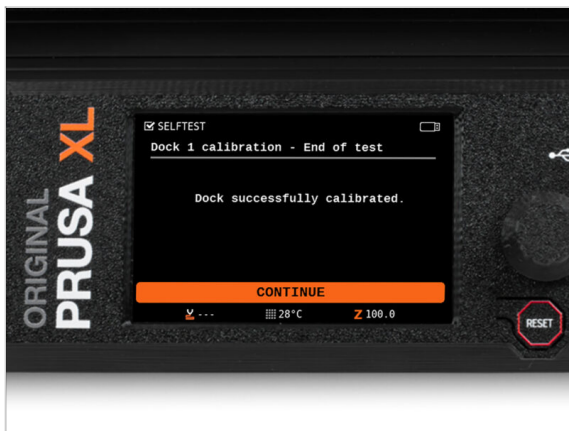

- Good job! Dock 1 is calibrated.
- Repeat the calibration process for all printheads.

## STEP 19 Wizard: Loadcell test



- ◆ The next step of the wizard will prompt you to touch the nozzle to test and calibrate the Loadcell. Parts of the printer are not heated during this test; you can touch the parts of the printer. Click on **Continue**.
- ◆ **Do not touch the nozzle yet.** Wait until the countdown finishes and the printer notifies you with a sound and display prompt.
- ◆ Tap the nozzle gently but firmly. Do not use excessive force. In case the loadcell does not detect your touch, you will be prompted to repeat the step.
- ⓘ Repeat the loadcell test according to the number of print heads.
- 📌 After this step, proceed to the **Z Axis test** and the **Nozzle heater test** respectively. These two tests are automatic and require minimal input.

## STEP 20 Wizard: Calibrate Filament Sensors



- ◆ The printer will ask if you would like to remap the third side filament sensor. Select **Left**. Change the side only in case you do not have enough space around the printer for the third spoolholder on the left side.
- ◆ During the calibration of the filament sensors, you will be prompted to use at least 130 cm of filament. Use the Prusament shipped with your printer and mount it on the spool holder.
- ◆ When you have prepared the filament, click on **Yes**.
- ◆ Wait for the printer to prompt you to insert the filament into the side filament sensor.

## STEP 21 Wizard: Calibrate Filament Sensors

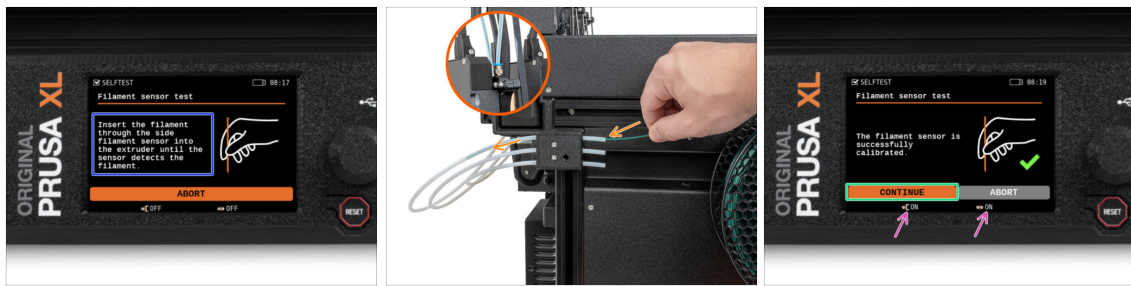

- ◆ Insert the filament into the side filament sensor through the PTFE tube. Push it in until it reaches the filament sensor in the extruder (you will feel a slight resistance).
- ◆ You can check the side filament sensor (left) and extruder filament sensor (right) status on the bottom bar on the screen.
- ◆ At the end of the test, you will be prompted to **remove the filament from the sensor**.
- i According to the number of print heads, repeat the filament sensor calibration process.
- ◆ Once all five filament sensors are successfully calibrated and tested, the printer will move on to the tool offset calibration. This will require your input. Move on to the next step →

## STEP 22 Calibration pin: parts preparing

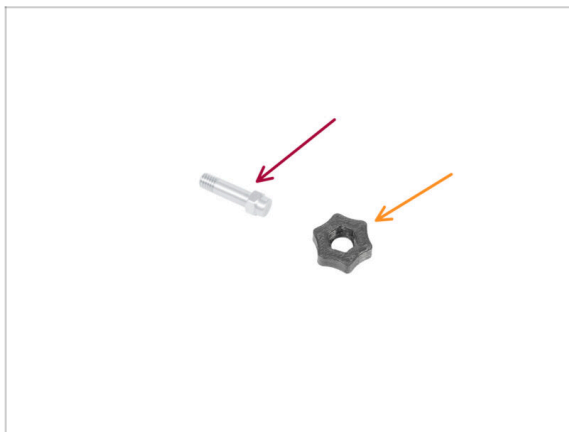

- ◆ For the next step, please prepare:
  - ◆ Calibration pin (1x)
  - ◆ Calibration-pin-key (1x)

## STEP 23 Calibration pin: parts assembly

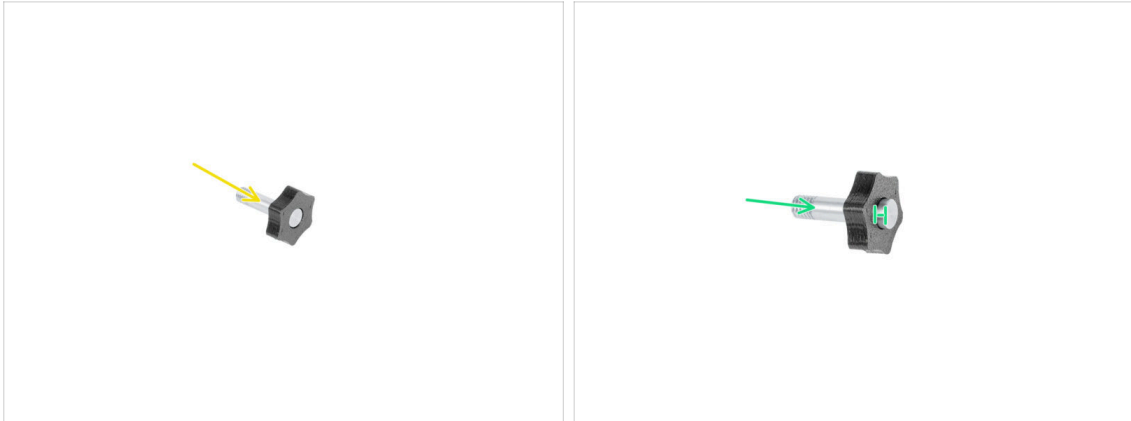

- Insert the calibration pin into the plastic part.
- Push the pin into the plastic part, creating a small protrusion on top.
- Well done, the pin is prepared.

## STEP 24 Wizard: Tool Offset Calibration



- During offset calibration, you will need to screw the calibration pin into the center of the heatbed.
- Have the calibration pin ready.
- Click on *Continue* to start the Tool Offsets Calibration.
- Only when you are re-doing the calibration at a later point do the nozzles have to be properly cleaned. **The second screen does not apply to the initial calibration. Click on continue.**

## STEP 25 Wizard: Sheet install



- ◆ Follow the wizard instructions on the screen.
- ◆ If you do not already have the print sheet on the heatbed, follow the instructions and place the print sheet on the heatbed.
- ⓘ Once the print sheet is in place, the printer starts short calibration.

## STEP 26 Wizard: Calibration pin installation

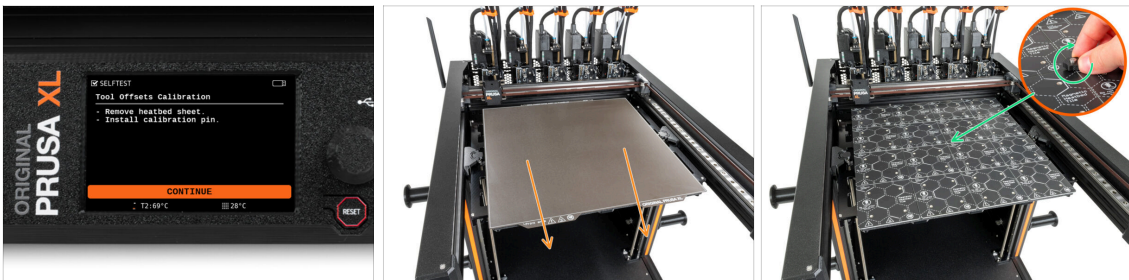

- ◆ Follow the wizard instructions on the screen.
- ◆ The wizard will remind you that for this calibration, the nozzles and parking plate have to be clean. It is assumed that they are for the first calibration, and you can click on ***Continue***.
- ◆ Remove the print sheet from the heatbed.
- ◆ Install the calibration pin into the middle of the heatbed. Turn the pin clockwise gently and without excessive force, until it is completely screwed in. **Then remove the plastic calibration-pin-key from the calibration pin.**
- ⓘ The printer will now calibrate all the tool heads.

## STEP 27 Wizard: Offset calibration done

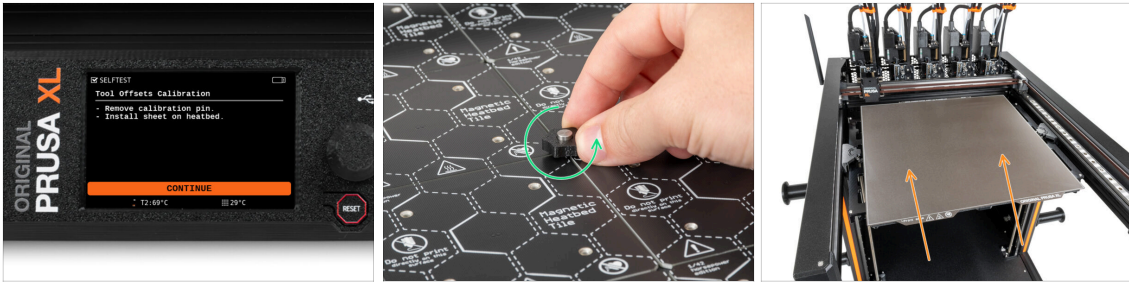

- ◆ Follow the wizard instructions on the screen.
- ◆ Once prompted, reattach the plastic calibration-pin-key to loosen the calibration pin. Rotate it counterclockwise and remove it from the heatbed.
- ◆ Place the print sheet onto the heatbed.
- ⓘ The printer will finish the calibration.
- ◆ Good job! The offset calibration is done.

## STEP 28 Calibration pin



- ◆ Insert the calibration pin into the left side filament sensor.
- ◆ After the offset calibration is completed, **the printer will automatically initiate the heatbed heater check.**
- ⓘ The heatbed doesn't reach its maximum temperature (115°C) during the heatbed heater test. The aim is to check the heating speed.

## STEP 29 Wizard: Phase stepping



- ◆ **The last step is the phase stepping calibration.** This feature was introduced in firmware version 6.0.0. The calibration is automatic. Follow the instructions on the screen.
- ⓘ You can find more information about the phase stepping via the following links:
  - 📌 **PHASE STEPPING GUIDE:** Necessary information about the phase stepping calibration.
  - 📌 **PHASE STEPPING BLOG ARTICLE:** A more in-depth look at the phase stepping feature.
- ⓘ The printer will move the first print head to the middle of the heatbed and move the tool diagonally for the X and Y axes at different speeds.
- After the printer completes the test, the screen will show by how much the motor vibrations were reduced.

## STEP 30 It's done

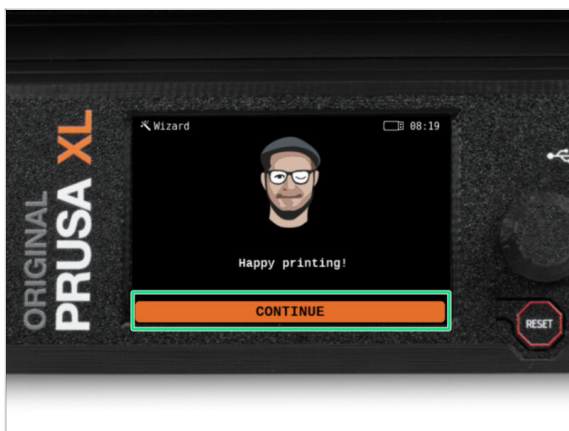

- ◆ **Well done! The printer is ready to print.** However, follow the instructions in this manual to the end.

## STEP 31 Prusa nextruder sock (Optional)



- i** The nextruder sock helps to keep the temperature in the heater block stable. It also keeps your hotend clean from filament dirt and protects it in case the print detaches from the print surface.
- ◆** A silicone sock is supplied with each Nextruder package.
- ◆** **If you want to install the sock, we recommend doing it after the calibration.**
- i** How to install the sock - check the article.

## STEP 32 Regular printer maintenance

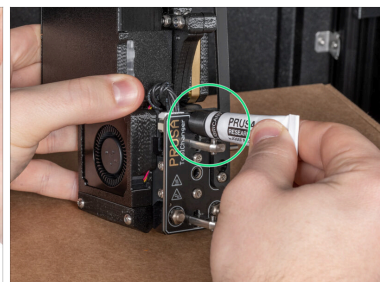

- i** To keep your printer working properly over time, it is highly recommended to do regular maintenance.
- ◆** For regular printer maintenance, follow the Regular printer maintenance (XL) article for information and instructions.
- 📌** On multi-tool printers, it is necessary to focus on lubricating the coupler pins of the ToolHeads.
  - i** Lubricating the coupler pins can be made along with the rest of the maintenance, or it can also be done if you notice that your prints have banding or ringing issues.
  - ◆** To lubricate the coupler pins use our dedicated online guide How to lubricate the coupler pins on Original Prusa XL.
  - i** You will need to print an applicator to lubricate the pins. Please refer to the dedicated guide for more information.

## STEP 33 Quick guide for your first prints



Now, please read the **3D Printing Handbook**, which is tailor-made for your printer and **follow the instructions to set up the printer properly**. The latest version is always available at **this link**.



**Read the chapters *Disclaimer* and *Safety instructions*.**

## STEP 34 Printable 3D models

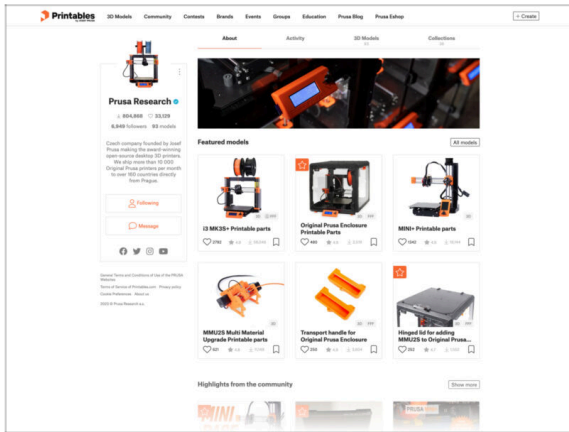

**Congratulations! You should be ready to print by now ;-)**



You can start by printing some of our test objects bundled on the included USB stick - you can check them out in this collection.

## STEP 35 Give us feedback



- ◆ We know you're eager to start printing, but we'd really appreciate it if you could take 3–4 minutes to **share your thoughts** on this manual: how clear it was, how easy it was to follow, and any ideas to improve it.
  - ❗ This feedback is a little different from the usual comments you might leave on individual steps.
- ◆ **Share your feedback here.**
- ◆ Thank you for helping us make our manuals even better!

## STEP 36 Prusa knowledge base

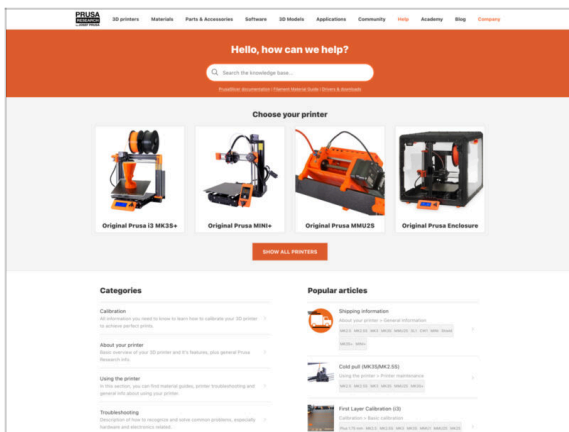

- ◆ If you encounter any problems at all, don't forget you can always check out our knowledge base at [help.prusa3d.com](https://help.prusa3d.com)
- ◆ We're adding new topics every day!

## STEP 37 Join Printables!

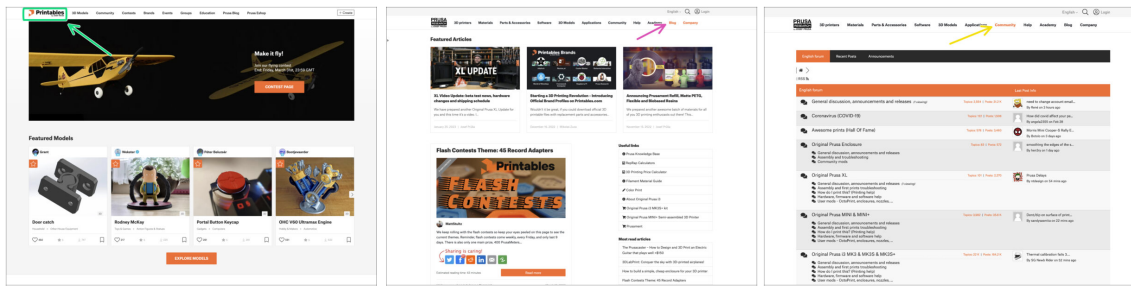

- ◆ **Don't forget to join the biggest Prusa community! Download the latest models in STL or G-code tailored for your printer. Register at [Printables.com](https://www.printables.com)**
- ◆ Looking for inspiration on new projects? Check our blog for weekly updates.
- ◆ If you need help with the build, check out our forum with a great community :-)
- i All services share one account.

## STEP 38 Haribo time!

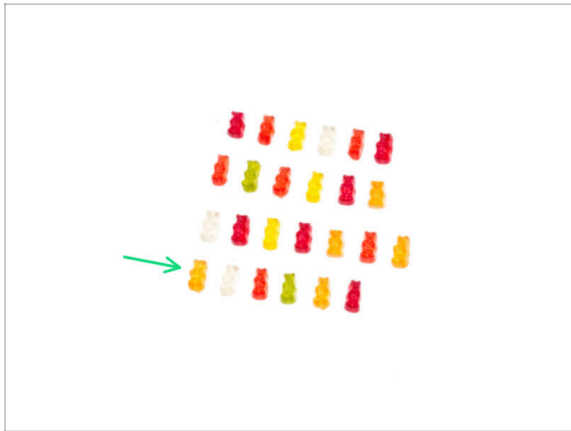

- ◆ **Congratulations! You did it.** The printer should already be up and running, and you can enjoy the last row of gummy bears: six gummy bears.
- i **Disclaimer: You have a lot of gummy bears left. Do not eat all the leftover gummy bears all at once by yourself now!** As much as it sounds like it could be fun, trust us... You do not want to **bear** the consequences.
- ◆ We recommend re-sealing the bag and placing it near the printer while making sure to protect the Haribo from heat and moisture. You can have a few anytime your printer is heating up, or you are eagerly waiting for your project to finish printing.
- i Did you know that gummy bears have a long shelf life? Typically lasting for up to two years if stored properly in a cool and dry place. But don't test that with our gummy bears.

# Manual changelog Five-Head (Assembled)

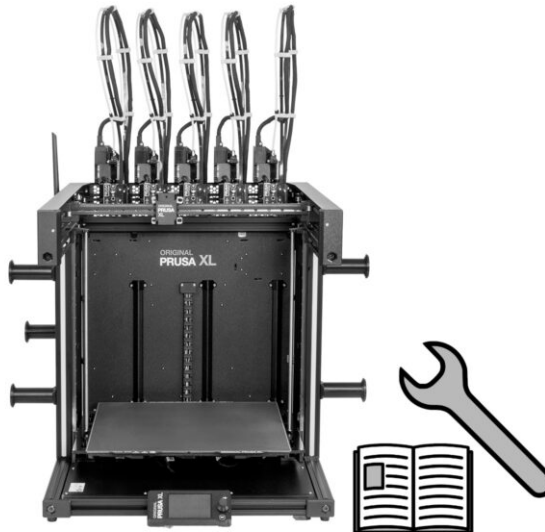

## STEP 1 Version history

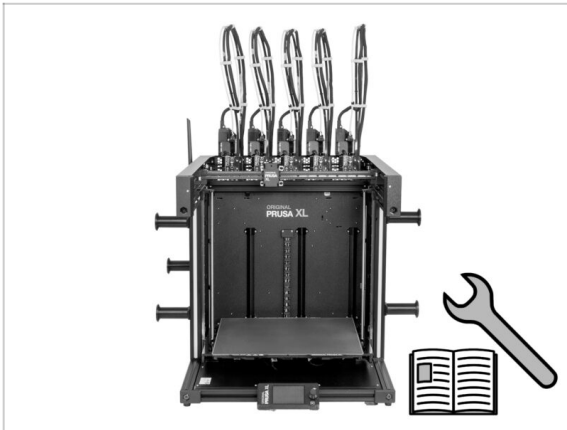

- **Versions of the Original Prusa XL semi-assembled (single tool) manual:**
- 06/2023 - Initial version 1.00
- 07/2023 - Updated to version 1.02
- 08/2023 - Updated to version 1.03
- 11/2023 - Updated to version 1.04
- 05/2024 - Updated to version 1.05
- 09/2024 - Updated to version 1.06
- 04/2025 - Updated to version 1.07

## STEP 2 Changes to the manual (1)

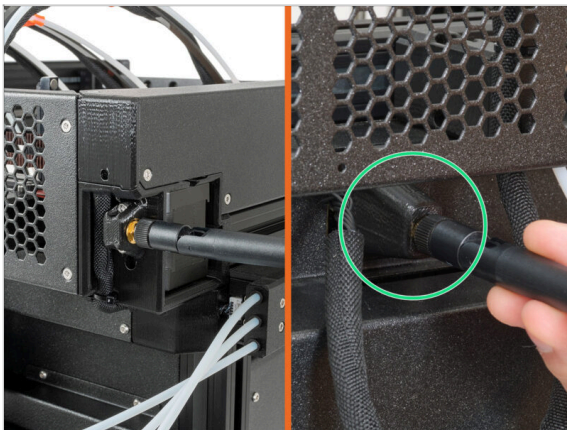

- 08/2023 - Antenna adapter
- Added instructions for the new antenna adapter.
- ⓘ Manual version 1.01

---

### STEP 3 Changes to the manual (2)

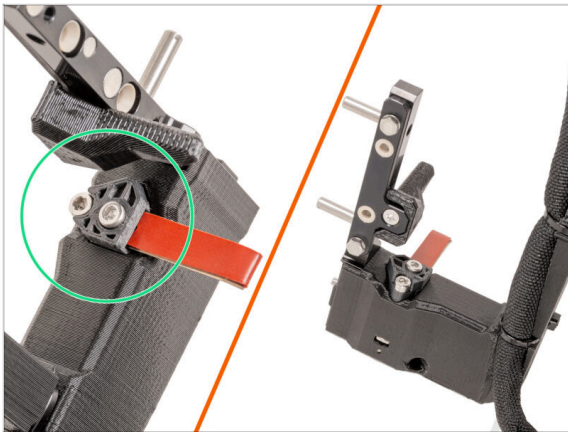

- 08/2023 - Nextruder dock
- Added instructions for the new dock.
- ⓘ Manual version 1.02

---

### STEP 4 Changes to the manual (4)



- 11/2023 - Spoolholder
- Added instructions for the new injection molded Spoolholder.
- Manual version 1.04

---

## STEP 5 Changes to the manual (5)

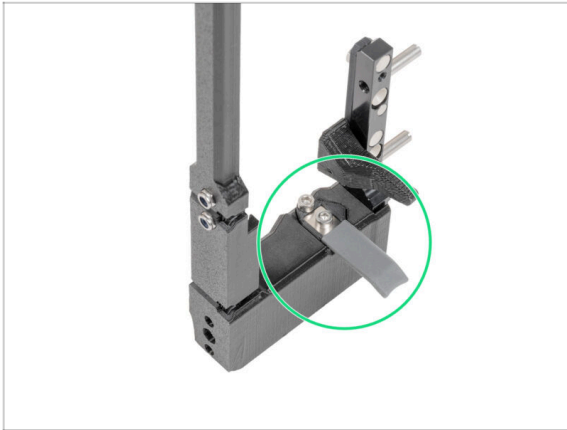

- 05/2024
  - Added information about the new gray nozzle seal.
- Manual version 1.05

---

## STEP 6 Changes to the manual (6)



- 09/2024 - xLCD
  - Added instructions for the new injection molded xLCD.
- Manual version 1.06

---

## STEP 7 Changes to the manual (7)

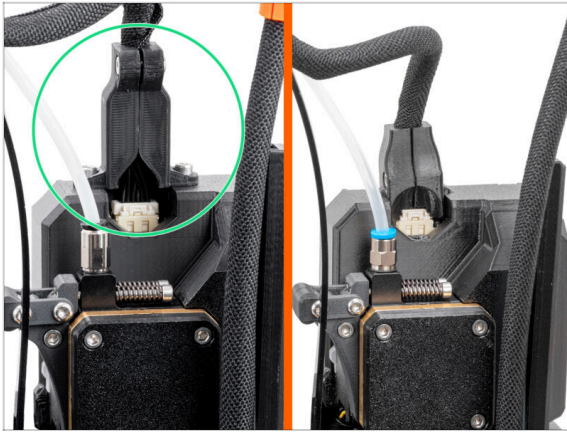

- 04/2025 - xLCD
- Added instructions for the new main cable connector cover.
- Manual version 1.07











