

# Table of Contents

<b>1. Introduction</b>	5
Step 1 - Preparing the upgrade kit	6
Step 2 - Getting the necessary tools	6
Step 3 - Getting the necessary tools	7
Step 4 - Labels guide	7
Step 5 - Cheatsheet	8
Step 6 - Front, left, right and rear side	8
Step 7 - Manipulating with the printer	9
Step 8 - Spare nozzles	9
Step 9 - Silicone sock	10
Step 10 - CAUTION: Lubricant Handling	10
Step 11 - View high resolution images	11
Step 12 - We are here for you!	11
Step 13 - How to successfully finish the assembly	12
Step 14 - Prepare your desk	13
<b>2. Printer preparing</b>	14
Step 1 - Preparing the printer	15
Step 2 - Protecting the heatbed	15
Step 3 - Printer unplugging	16
Step 4 - Can I open the Haribo?	16
Step 5 - Haribo	17
Step 6 - Let's get started	17
<b>3. Detaching the Nextruder</b>	18
Step 1 - Tools necessary for this chapter	19
Step 2 - Wi-Fi antenna detaching	19
Step 3 - PTFE unplugging	20
Step 4 - Disconnecting the Nextruder cable	20
Step 5 - Nextruder cable bundle unplugging	21
Step 6 - Nextruder undocking	21
Step 7 - Nextruder nozzle seal	22
Step 8 - Nextruder dock detaching	22
Step 9 - Haribo	23
Step 10 - Good job!	23
<b>4. PSU &amp; electronics assembly</b>	24
Step 1 - Tools necessary for this chapter	25
Step 2 - Back antenna disconnecting	25
Step 3 - Back antenna disassembly	26
Step 4 - Back covers disassembly	26
Step 5 - PSU assembly: parts preparation	27
Step 6 - PSU assembly: PSU preparing	27
Step 7 - PSU assembly: PSU preparing	28
Step 8 - PSU assembly: printer preparing	28
Step 9 - Attaching the PSU	29
Step 10 - Securing the PSU	29
Step 11 - PSU covers: parts preparations	30
Step 12 - PSU covers: side cover	30
Step 13 - PSU covers: lower cover	31
Step 14 - PSU power cable cover: parts preparation	31
Step 15 - PSU power cable cover: lower cover	32
Step 16 - PSU power cable cover: power cable	32

Step 17 - PSU power cable cover: middle cover .....	33
Step 18 - PSU power cable cover: upper cover .....	33
Step 19 - XL-splitter: parts preparation .....	34
Step 20 - Installing the XL_splitter .....	34
Step 21 - Filament sensor cable: parts preparation .....	35
Step 22 - Filament sensor cable: connecting the cable .....	35
Step 23 - Metal plate cable covers: parts preparations .....	36
Step 24 - Adjusting the XL-buddy-box-cover .....	36
Step 25 - Lower metal plate cable covers .....	37
Step 26 - Upper metal plate cable covers .....	37
Step 27 - XL buddy cover .....	38
Step 28 - Reward yourself! .....	38
Step 29 - Well done! .....	39
<b>5. Nextruder &amp; accessories assembly .....</b>	<b>40</b>
Step 1 - Tools necessary for this chapter .....	41
Step 2 - Filament sensor: parts preparation .....	41
Step 3 - Right filament sensor .....	42
Step 4 - Nextruder cable: parts preparation .....	42
Step 5 - Nozzle seal versions .....	43
Step 6 - Version C: preparing the dock .....	43
Step 7 - Guiding the Nextruder cable .....	44
Step 8 - Attaching the Nextruder docks .....	44
Step 9 - Dock inspection .....	45
Step 10 - Dock inspection: video .....	45
Step 11 - Version C: Nozzle seal: parts preparation .....	46
Step 12 - Version C: Installing the Nextruder nozzle seal .....	46
Step 13 - Connecting the Nextruder cables .....	47
Step 14 - Wi-fi antenna holder versions .....	47
Step 15 - Installing the rear Wi-Fi antenna holder .....	48
Step 16 - Connecting the side Wi-Fi antenna .....	48
Step 17 - Connecting the Nextruder cables .....	49
Step 18 - XL buddy box covering .....	49
Step 19 - Guiding the docks PTFE tubes .....	50
Step 20 - Guiding the docks PTFE tubes .....	50
Step 21 - Installing the Wi-Fi antenna: parts preparation .....	51
Step 22 - Installing the Wi-Fi antenna .....	51
Step 23 - Spool holder: parts preparation .....	52
Step 24 - Assembling the spool holder .....	52
Step 25 - Preparing the spool holder .....	53
Step 26 - Spool holder: left side .....	53
Step 27 - Spool holder: right side assembly .....	54
Step 28 - Nextruder assembly: parts preparation .....	54
Step 29 - Docking the Nextruder .....	55
Step 30 - Nextruder cable bundle assembly .....	55
Step 31 - Nextruder cable bundle assembly .....	56
Step 32 - Nozzle seal height calibration .....	56
Step 33 - Nozzle seal height calibration .....	57
Step 34 - Haribo time! .....	57
Step 35 - Remaining fasteners .....	58
Step 36 - Almost done! .....	58
<b>6. First run .....</b>	<b>59</b>
Step 1 - Before you start with Multi-Tool .....	60
Step 2 - Preparing the printer .....	60
Step 3 - Factory reset .....	61

Step 4 - Prusa Nextruder sock (Optional) .....	61
Step 5 - Wizard .....	62
Step 6 - Wizard: Dock Position Calibration .....	62
Step 7 - Wizard: Loosen pin .....	63
Step 8 - Wizard: Loosen screws .....	63
Step 9 - Wizard: Lock the tool .....	64
Step 10 - Wizard: Tighten the upper screw .....	64
Step 11 - Wizard: Tighten the lower screw .....	65
Step 12 - Wizard: Install pins .....	65
Step 13 - Wizard: Dock successfully calibrated .....	66
Step 14 - Wizard: Test Loadcell .....	66
Step 15 - Wizard: Recalibrate Filament Sensors .....	67
Step 16 - Wizard: Recalibrate Filament Sensors .....	67
Step 17 - Wizard: Recalibrate Filament Sensors .....	68
Step 18 - Calibration pin: parts preparing .....	68
Step 19 - Calibration pin: parts assembly .....	69
Step 20 - Wizard: Tool Offset Calibration .....	69
Step 21 - Wizard: Sheet install .....	70
Step 22 - Wizard: Calibration pin installation .....	70
Step 23 - Wizard: Offset calibration done .....	71
Step 24 - Calibration pin .....	71
Step 25 - It's done .....	72
Step 26 - Reward yourself! .....	72
Step 27 - Checking the Heatbed installation (Semi-Assembled printer) .....	73
Step 28 - Quick guide for your first prints .....	73
Step 29 - Printable 3D models .....	74
Step 30 - Prusa knowledge base .....	74
Step 31 - Join Printables! .....	74
<b>Manual changelog XL (Dual-Head to Five-Head upgrade) .....</b>	<b>75</b>
Step 1 - Version history .....	76
Step 2 - Changes to the manual (1) .....	76



# 1. Introduction

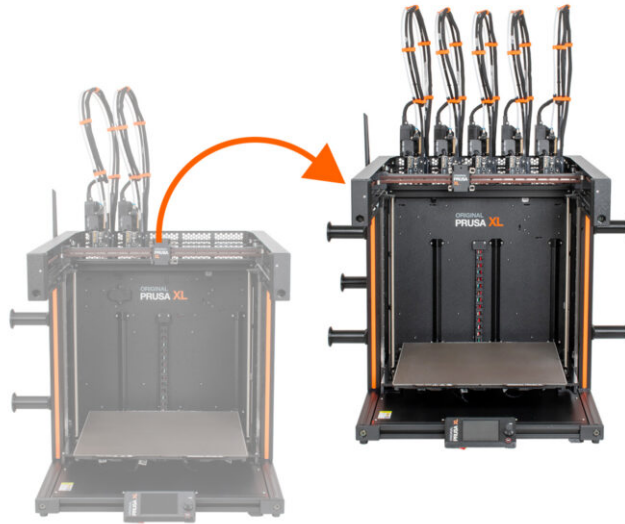

## STEP 1 Preparing the upgrade kit

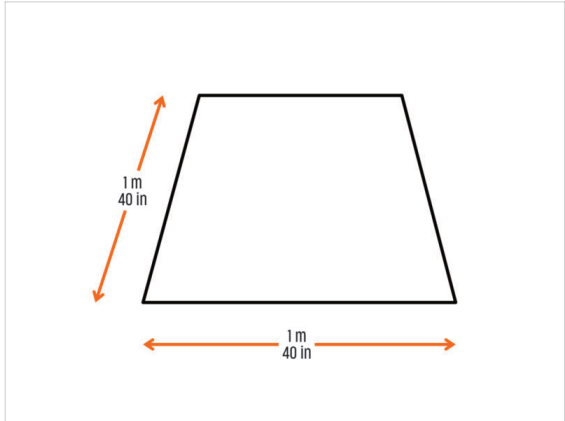

- Welcome to the tutorial on how to upgrade your Original Prusa XL Dual-Head to **Original Prusa XL Five-Head**.
- Please prepare the upgrade kit received from Prusa Research.
- For the assembly, prepare a clean workbench with a space of at least 1 m x 1 m (40 in x 40 in).

## STEP 2 Getting the necessary tools

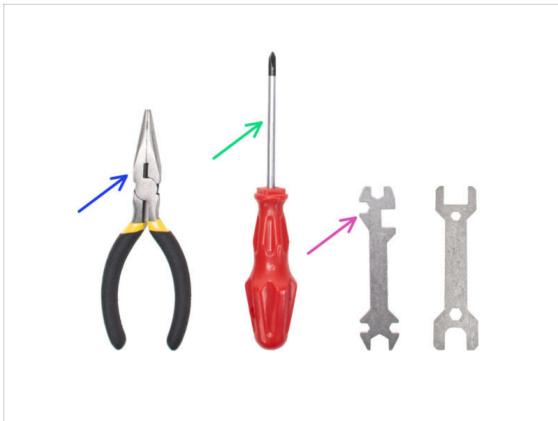

- **The package includes:**
- Needle-nose pliers (1x)
- Philips (PH2) screwdriver (1x)
- Universal wrench (1x)
- Nexttruder box as a heatbed cover.
- Continue to the next step.

### STEP 3 Getting the necessary tools

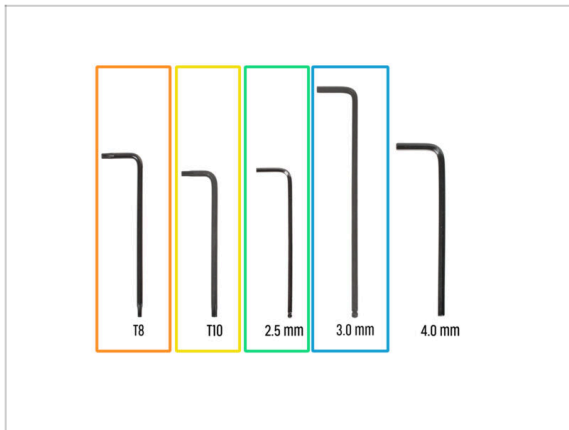

● **The package includes:**

- T8 Torx key
- T10 Torx key (T10 Torx screwdriver)
- 2.5 mm Allen key
- 3.0 mm Allen key

### STEP 4 Labels guide



- All the boxes and bags including parts for the build are labeled.
- The amount of parts is written on the label. This number is included in the total number of each type of part.

## STEP 5 Cheatsheet



- ◆ For accurate assembly, it is recommended to use a Cheatsheet that contains 1:1 scale drawings for accurate comparison of fasteners and some other parts.
- ⓘ You can download it from our site [prusa.io/cheatsheet-xl](https://prusa.io/cheatsheet-xl). Print it at 100 %, don't rescale it, otherwise, it won't work.
- ◆ The frame covers are 1:1 scale, so you can compare the size by placing the frame cover on the paper to make sure you are using the correct type.

## STEP 6 Front, left, right and rear side

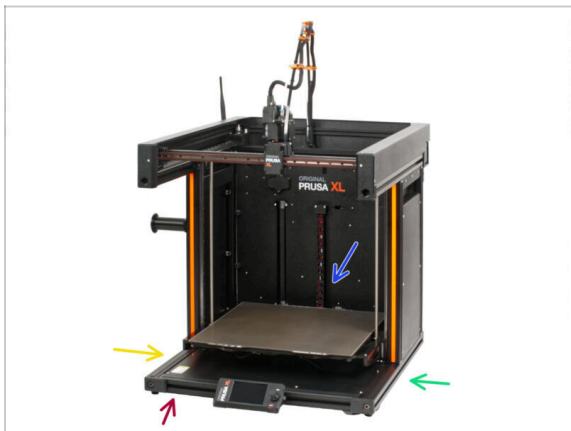

**⚠ IMPORTANT:** The XL printer is large and it is almost impossible to have the entire body in every single picture. Throughout the manual, there will used terms to describe the side you will be working on:

- ◆ **Front side** - the location featuring the xLCD screen.
- ◆ **Left side** - identifiable by the **safety sticker** positioned along its edge.
- ◆ **Right side** - in contrast to the left side, **lacks a safety sticker**.
- ◆ **Rear side** - the remaining section housing the **PSU** (Power Supply Unit).



## STEP 7 Manipulating with the printer

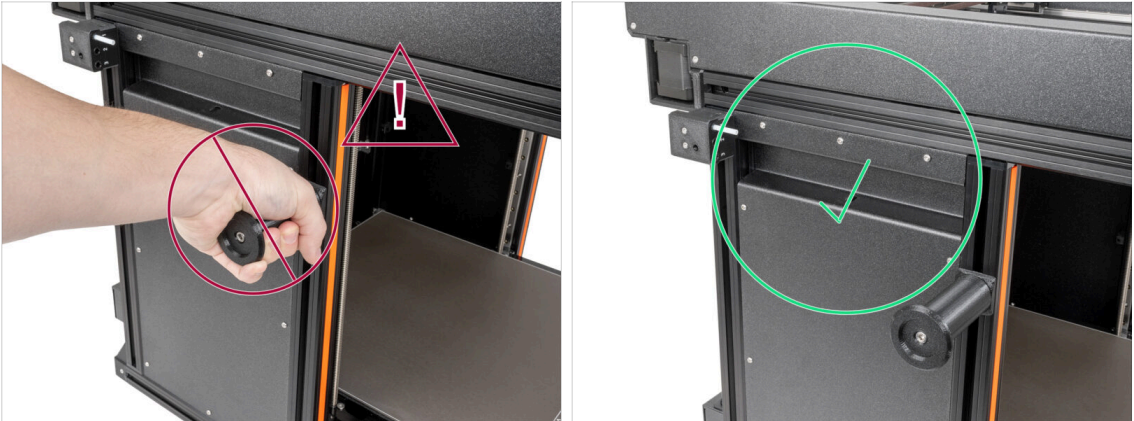

**⚠** Never manipulate the printer by using the upper metal flanges. You can damage the LED lights hidden inside.

◆ When assembling, handle the base using the extrusions.

## STEP 8 Spare nozzles



- i** The Nextrunder upgrades come with pre-installed 0.4mm nozzles.
- ◆ You'll find spare nozzles in the upgrades. You can replace the nozzle on your existing Nextrunder with a new 0.4 mm diameter nozzle
- ◆ For replacing the Prusa nozzle, go to [How to replace the Prusa Nozzle \(XL multi-tool\)](#)

## STEP 9 Silicone sock



- A silicone sock is supplied with each Nextruder package.
- The main function of a silicone sock is to keep the temperature in the heater block stable, which improves the printer's performance.
- ⓘ Also, it keeps your hotend clean from filament dirt and protects it in case the print detaches from the print surface.
- You will be asked to install the sock later in this guide.
- ⓘ How to install the sock - [check the article](#).

## STEP 10 CAUTION: Lubricant Handling

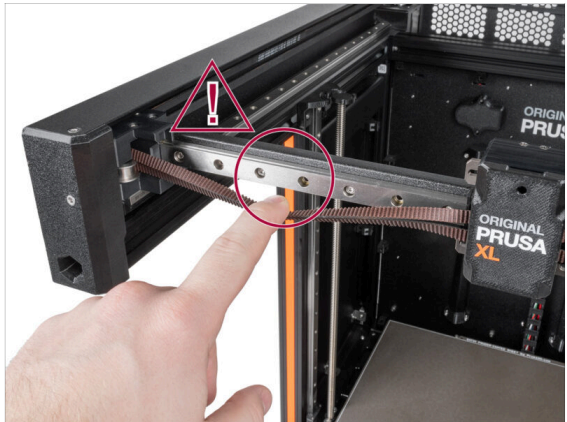
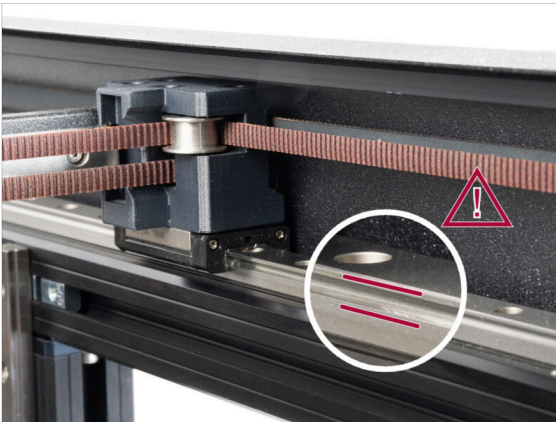

- ⚠ **CAUTION: Avoid direct skin contact with the lubricant used for the linear rails in this printer. If a contact occurs, wash your hands immediately. Especially before eating, drinking, or touching your face.**
- Lubricant accumulates in the printer's bearings, mainly in the linear rail channels.

## STEP 11 View high resolution images

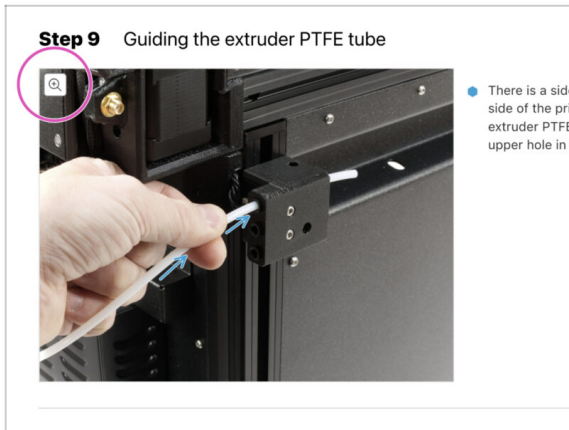

**i** When you browse the guide on [help.prusa3d.com](https://help.prusa3d.com), you can view the original images in high resolution for clarity.

Just hover your cursor over the image and click the Magnifier button ("View original") in the top left corner.

## STEP 12 We are here for you!

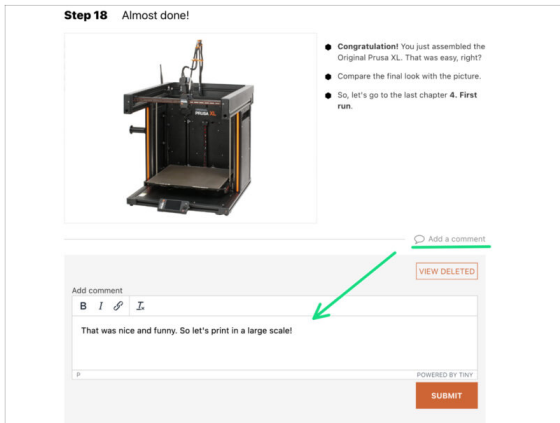
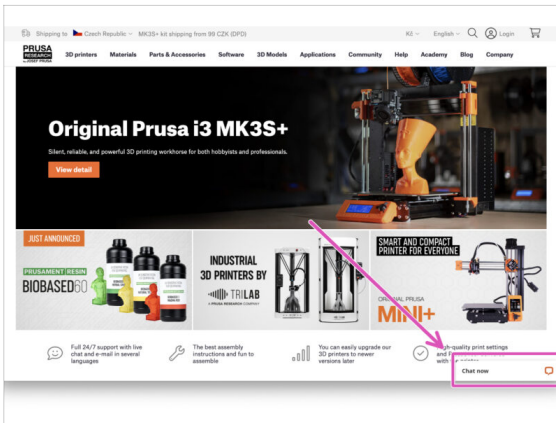





- Lost in the instructions? Missing screw or cracked printed part? **Let us know!**
- You can contact us using following channels:
  - Using comments under each step.
  - Using our 24/7 live chat at [shop.prusa3d.com](https://shop.prusa3d.com)
  - Writing an email to [info@prusa3d.com](mailto:info@prusa3d.com)

## STEP 13 How to successfully finish the assembly



 **To successfully finish the upgrade please follow all these:**

-  **Always read all the instructions at the current step first**, it will help you to understand what you need to do. Don't cut or trim unless you are told to!!!
-  **Don't follow pictures only!** It is not enough, the written instructions are as brief as they could be. **Read them!**
-  Read the comments from the other users, they are a great source of ideas. We read them too and based on your feedback improve the manual and the entire assembly.
-  **Use a reasonable force**, the printed parts are tough, but not unbreakable. If it doesn't fit, check your approach twice.
-  **Most important: Enjoy the build, have fun.** Cooperate with your kids, friends or partners.

## STEP 14 Prepare your desk



- ◆ Tidy up your desk! Tidying up decreases the probability of losing small parts.
- ◆ **Clear your workspace.** Make sure you have enough room. A nice clear flat workbench will get you the results you are aiming for.
- ◆ **Let there be light!** Make sure you are in a well-lit environment. Another lamp or even an extra flashlight will probably come in handy.
- ◆ Prepare something to contain the plastic bags and the removed packing materials so you can recycle them afterwards. Make sure there are no important parts being discarded.
- ◆ OK, we are ready. Let's start! Go to the next chapter **2. Printer preparing**

## 2. Printer preparing



### STEP 1 Preparing the printer

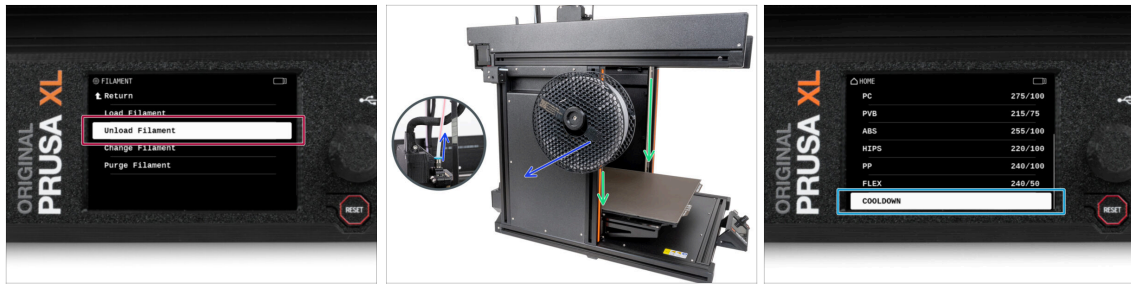

- ◆ If you have loaded the filament, unload it from the hotend. On the screen, navigate to *Filament* -> *Unload Filament*.
- ◆ Remove the filament from the hotend. It is necessary to completely remove it from the printer.
- ⚠ **WARNING: The hotend and heatbed are very HOT. Do not touch these parts!!!**
- ◆ Move the Z-axis down. On the screen, navigate to *Control* -> *Move axis* -> *Move Z*.
- ◆ Cool down the printer. On the screen, navigate to *Preheat* -> *Cooldown*.
- ⚠ **Wait until the hot parts are cooled down to ambient temperature. It takes approximately 10 minutes.**

### STEP 2 Protecting the heatbed



- ◆ **Before you proceed, it is recommended to protect the heatbed.**
- ◆ **Make sure the heatbed is cooled down to ambient temperature.** Place the empty cardboard box approximately to the front center part of the heatbed.

### STEP 3 Printer unplugging



- Turn the power switch OFF (symbol "O").
- From the rear side of the printer, unplug the PSU cable.

### STEP 4 Can I open the Haribo?



- ⚠ Keep the Haribo bag closed for now!**
- This dose of energy is primarily for printer assembly. **Wait until you are prompted to open it.**



## STEP 5 Haribo

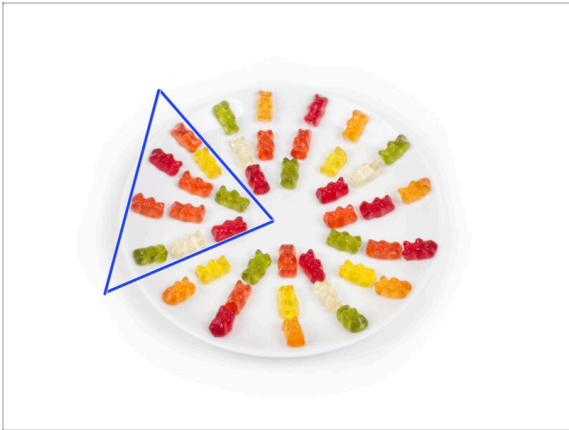

**⚠** Carefully and quietly open the bag with the Haribo sweets. High level of noise might attract nearby predators!

- Spread the entire contents of the bag on a clean plate and arrange them according to the picture. The color doesn't matter that much.
- ⓘ The total number in your package may vary slightly. However, the exact number is important. If any gummy bears are missing, please go to your nearest candy store immediately.
- Eat ten gummy bears.
- ⓘ **Did you know that** gummy bears were first created by a German candy maker named Hans Riegel in the 1920s.

---

## STEP 6 Let's get started



- Everything checked? So, let's start with disassembling the printer. Let's go to the next chapter: **3. Nextrunder detaching**

### 3. Detaching the Nextruder

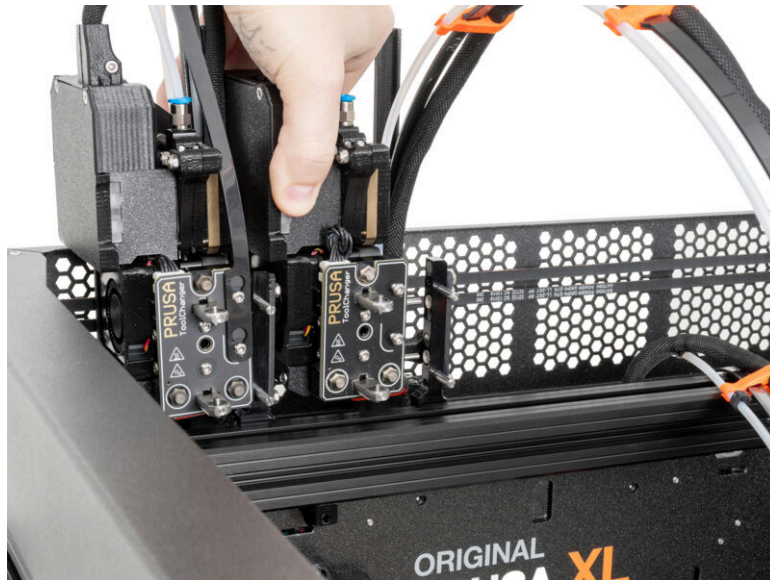

## STEP 1 Tools necessary for this chapter

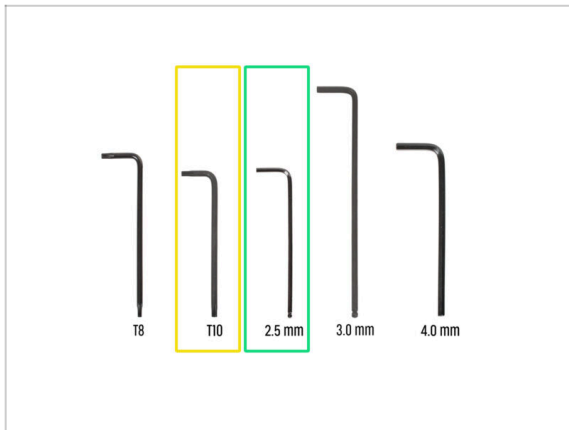

● For the next steps, please prepare:

● T10 Torx key

● 2.5 mm Allen key

## STEP 2 Wi-Fi antenna detaching

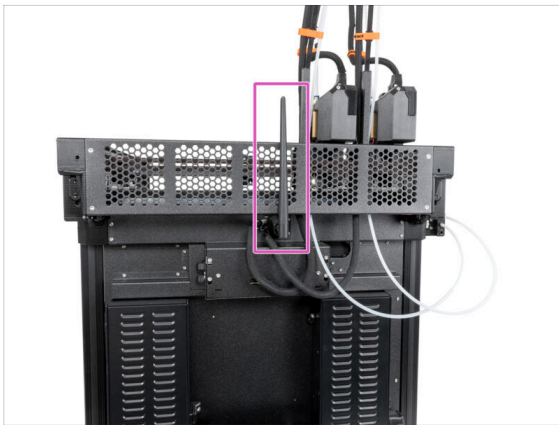

ⓘ This step is specific to printers equipped with a Wi-Fi antenna located on the back of the device. If you have a version of the printer with an antenna on the side, skip this step.

- Turn the printer, so the back side of the printer is facing you.
- Locate the Wi-Fi antenna connector in the middle of the printer.
- Loosen the Wi-Fi antenna from the antenna connector and set it aside.

#### STEP 3 PTFE unplugging



- Turn the printer so the left side (with filament sensor) is facing you.
- Push the black collet to release the PTFE tube.
- Pull out the Nextruder PTFE tube from the filament sensor.
- Repeat this process for the second Nextruder PTFE tube.

#### STEP 4 Disconnecting the Nextruder cable

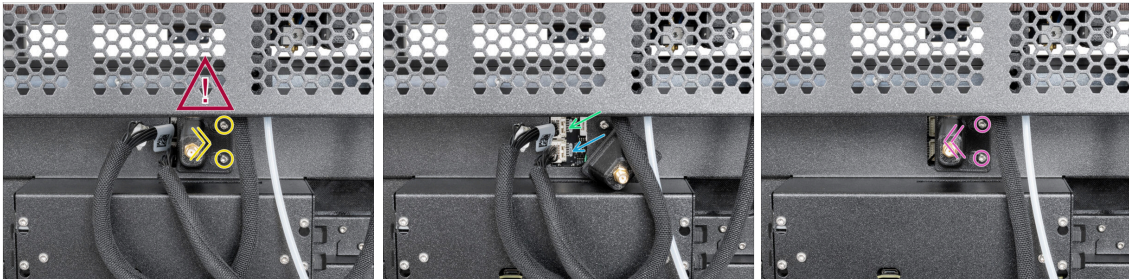

- ⚠ **There is an antenna cable behind the antenna-holder, do not pull the connector!**
- Loosen the two screws on the cover slightly. There's no need to completely remove them. Slide the cover to the right and take it off from the printer.
- Push the secure pin and disconnect the first Nextruder cable from the upper slot labeled DWARF 1.
- Push the secure pin and disconnect the second Nextruder cable from the lower slot labeled DWARF 2.
- Attach the cover to the screws. Push it all the way to the left and tighten the screws.

#### STEP 5 Nextruder cable bundle unplugging



- Turn the printer so the front side is facing you.
- Locate the FESTO fitting, press the blue collet and unplug the PTFE tube from the second Nextruder. Leave the PTFE hanging freely.
- Locate the Nextruder cable, press the secure pin and unplug the cable from the second Nextruder. Leave the cable hanging.
- Repeat this step for the first Nextruder.

#### STEP 6 Nextruder undocking

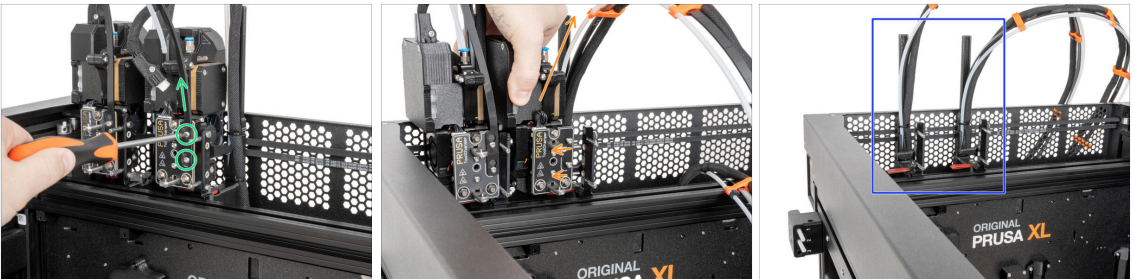

- From the front side of the Nextruder, using a T10 screwdriver, loosen (a few turns are enough) two M3x8r screws and take off the cable support.
- Gently undock the second Nextruder and put it aside.
- Repeat these steps for the first Nextruder.
- Good job! The docks look like this. We can continue.

#### STEP 7 Nextruder nozzle seal

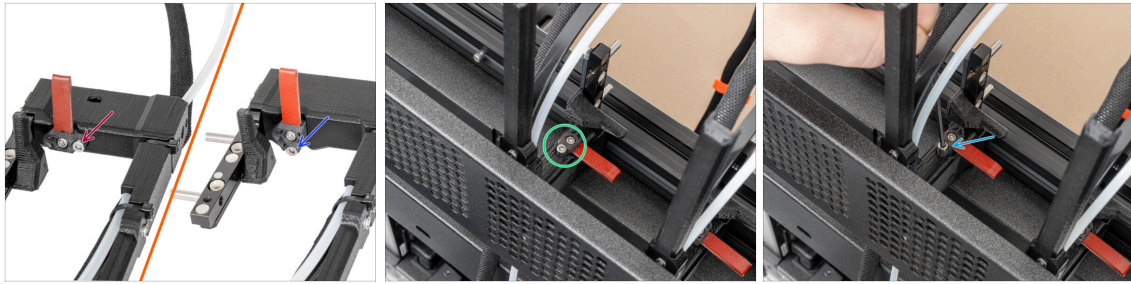

- ◆ This step is for printers that have the old dock. Use the first picture to compare and determine which type of dock you have, then follow the instructions:
  - ◆ If you have an older dock, please continue to the next line. **You have to remove the nozzle seal.**
  - ◆ If you have a new dock, please **continue to the next step.** There's no need to remove the nozzle seal.
- ◆ Locate the Nozzle seal in the dock.
- ◆ Using a 2.5 mm Allen key, untighten the screw and remove the nozzle seal (don't forget the spring).

#### STEP 8 Nextruder dock detaching

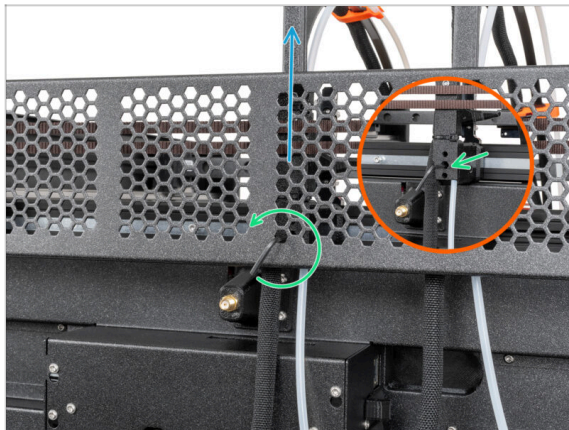

- ◆ Using a 2.5mm Allen key, untighten the screw inside the second Nextruder dock (middle hole).
- ◆ Remove the Nextruder dock.
- ◆ Repeat these steps for the first Nextruder dock.

## STEP 9 Haribo

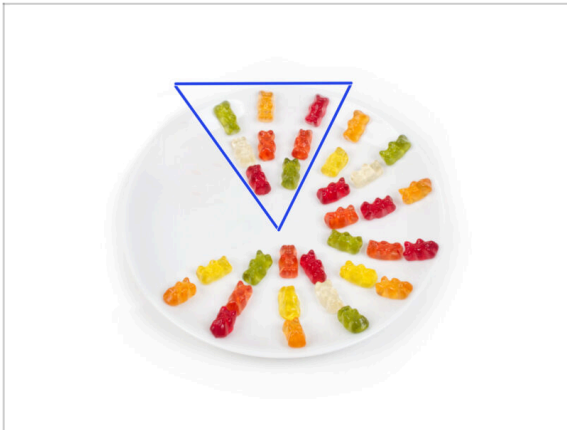

- ◆ Eat eight gummy bears.
- ⓘ **Did you know that** the original gummy bears were inspired by the dancing bears of Europe, and Riegel named them "Gummibärchen," which means "little rubber bears" in German.

---

## STEP 10 Good job!



- ◆ Well done! The printer is ready for the third PSU assembly.
- ◆ Let's go to the next chapter **4. PSU & electronics assembly**.

## 4. PSU & electronics assembly





## STEP 1 Tools necessary for this chapter

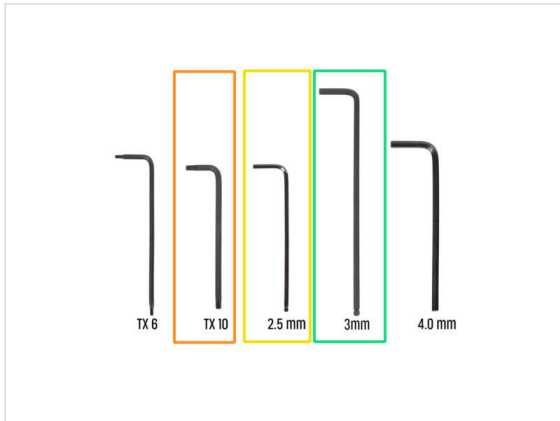
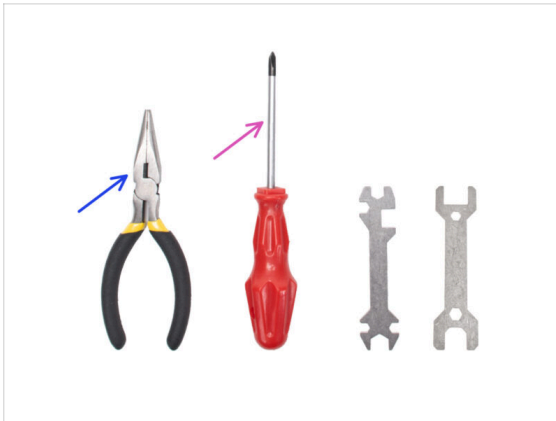

● For the next steps, please prepare:

- Needle-nose pliers (1x)
- Philips (PH2) screwdriver (1x)
- T10 Torx key / screwdriver
- 2.5 mm Allen key
- 3.0 mm Allen key

## STEP 2 Back antenna disconnecting

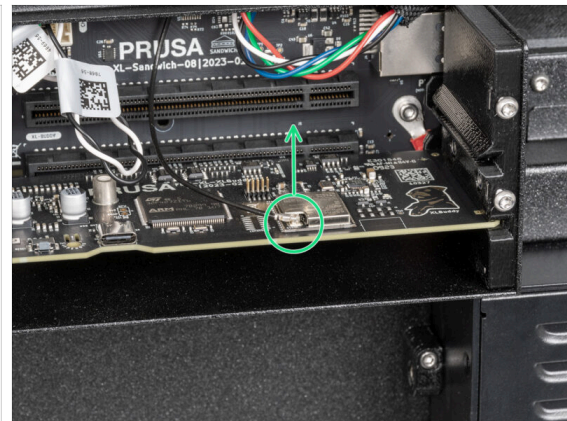

- Turn the printer, so the back side is facing you.
- Using a T10 Torx key, loosen four screws securing the electronics cover. Remove the cover.
- Locate and unplug the Wi-Fi connector.
- **i** If you have the **Wi-Fi antenna on the side** of the printer, **unplug the connector too**.

### STEP 3 Back antenna disassembly

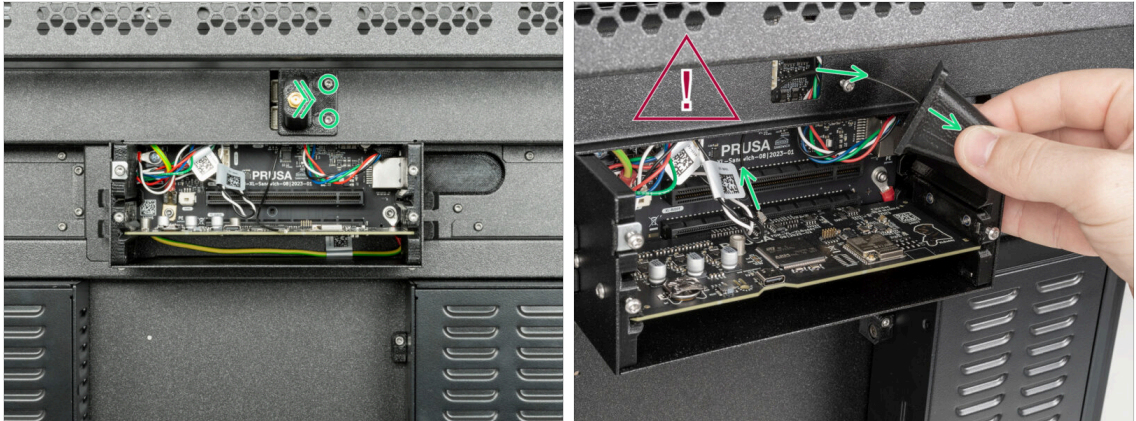

**i** This step is only for the printer, which has a Wi-Fi antenna on the back of the printer.

**!** **Be careful, do not damage the Wi-Fi antenna cable.**

**◆** Loosen two screws on the cover slightly. No need to remove them completely. Push the cover to the right and remove it from the printer.

### STEP 4 Back covers disassembly



**◆** Using a T10 Torx key, remove eight M3x4rT screws from the covers.

**◆** Gently remove the rear-cable-management-upper and rear-cable-management-lower. Be aware of the cables.

**◆** Using a T10 Torx key, remove two M3x4rT screws holding the rear-cable-management-base and remove it.

**◆** Cut two zip ties. **Be aware of cables!**

**◆** Good job. The back side of the printer is ready for the third PSU assembly.

## STEP 5 PSU assembly: parts preparation



For the following steps, please prepare:

- PSU (1x)
- M3x6 (2x)
- M3x20rT (1x)
- M4x12 (1x)
- PSU-upper-cover-mount (1x)
- Down-angled-ac-adaptor (1x)
- Power cable (1x)

## STEP 6 PSU assembly: PSU preparing

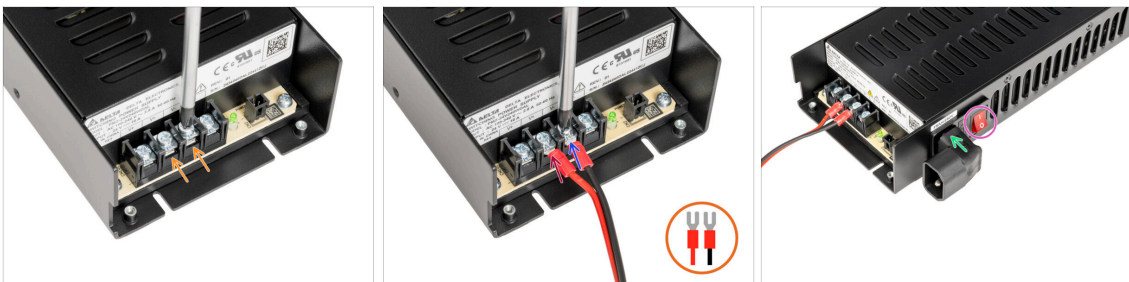

- Using a Phillips screwdriver, release two Terminal screws.
- Place the red cable on the left terminal and secure it with the terminal screw.
- Place the black cable on the right terminal and secure it with the terminal screw.
- From the side of the PSU, insert the Down-angled-ac-adaptor as described in the picture.
- Turn the power switch ON (symbol "I").

## STEP 7 PSU assembly: PSU preparing

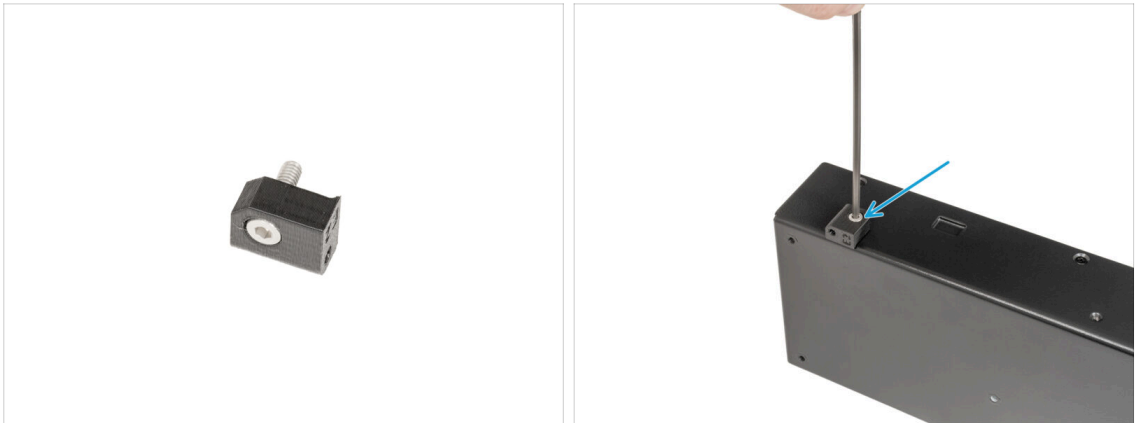

- ◆ Insert an M4x12 screw into the PSU-upper-cover-mount.
- ⓘ On the opposite side than the Down-angled-ac-adapter assembly.
- ◆ Attach the PSU-upper-mount-cover to the PSU and secure the M4x12 screw using a 3mm Allen key.

## STEP 8 PSU assembly: printer preparing

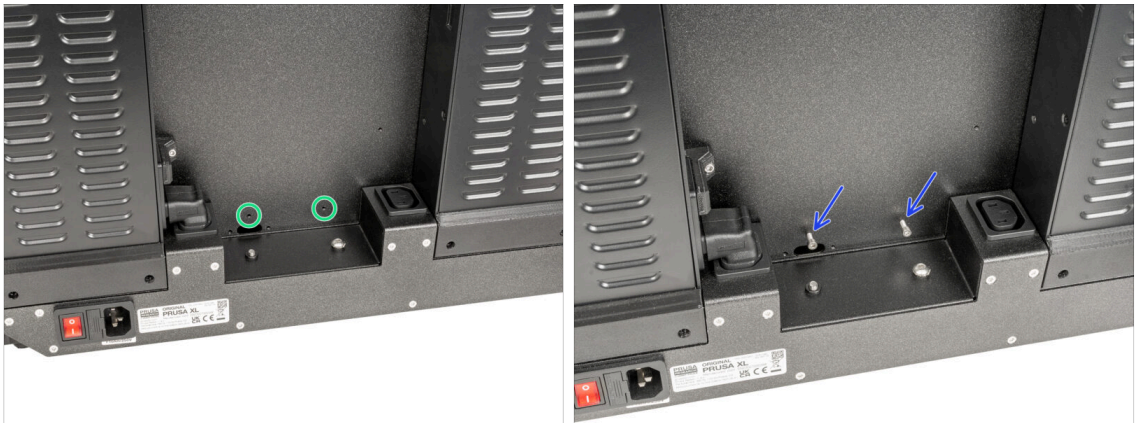

- ◆ Locate two holes on the back of the printer.
- ◆ Insert two M3x6 screws and secure them. **A few turns are enough for now.**

## STEP 9 Attaching the PSU

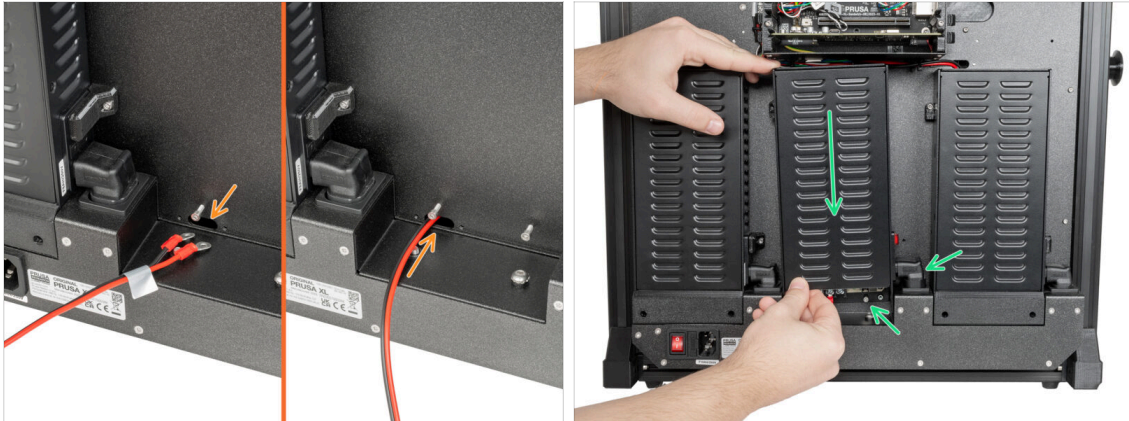

- ① Prepare the PSU behind the back side of the printer.
- 🟠 Insert the power cable through the hole in the back of the printer.
- 🟢 Gently attach the PSU to two M3x6 screws. Mind the Down-angled-ac-adapter.

## STEP 10 Securing the PSU

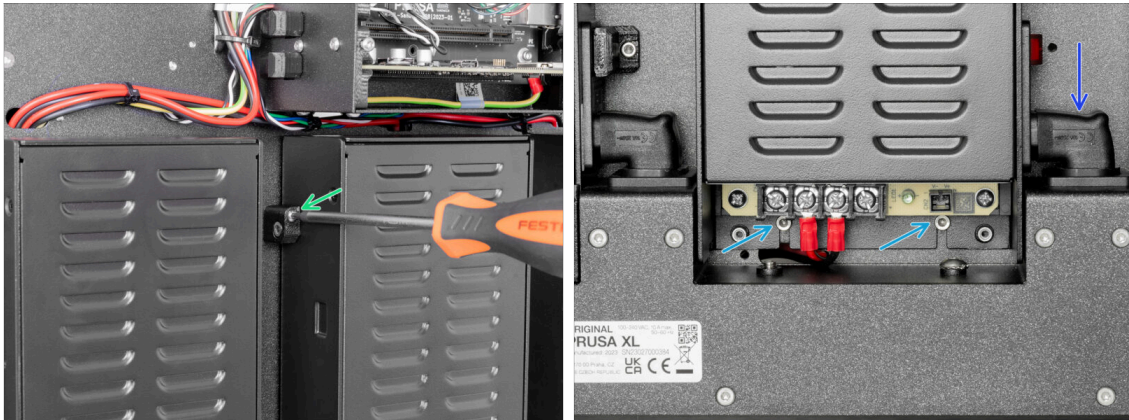

- 🟢 On the left side of the PSU, insert the M3x20rT screw into the PSU-upper-cover-mount and secure the cover with the back plate of the printer.
- 🟢 On the bottom of the PSU, tighten two M3x6 screws using a 2.5mm Allen key.
- 🟢 Pushing down the Down-angled-ac-adapter, secure its position.

## STEP 11 PSU covers: parts preparations

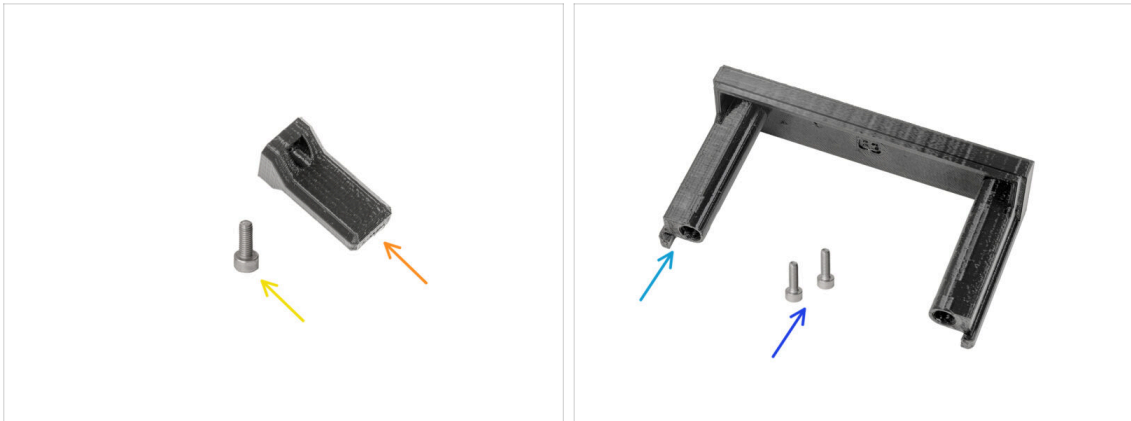

⬛ For the next steps, please prepare:

- 🟠 Switch cover (1x)
- 🟡 M3x8 screw (1x)
- 🟢 PSU cover (1x)
- 🟣 M3x10 screw (2x)

## STEP 12 PSU covers: side cover

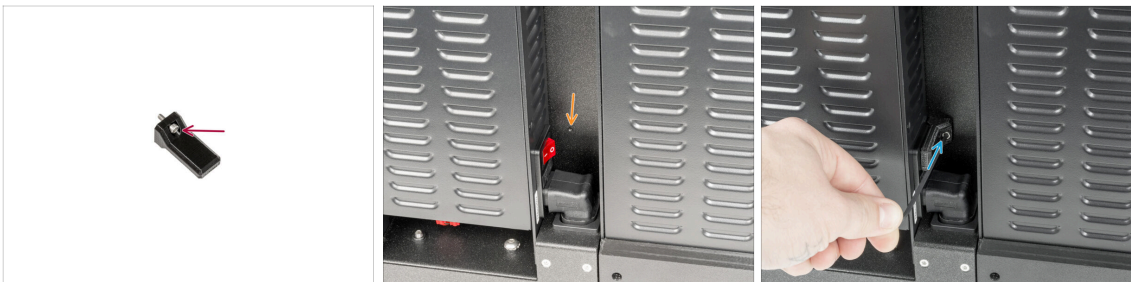

- 🔴 Insert the M3x8 screw into the switch-cover.
- 🟠 On the right side of the PSU, locate the hole in the back plate of the printer.
- 🟢 Using a 2.5mm Allen key, secure the cover screw with the back of the printer.

### STEP 13 PSU covers: lower cover



- Insert both M3x10 screws into the PSU cover.
- Insert the prepared PSU cover under the PSU.
- Tighten both M3x10 screws using a 2.5mm Allen key.

### STEP 14 PSU power cable cover: parts preparation

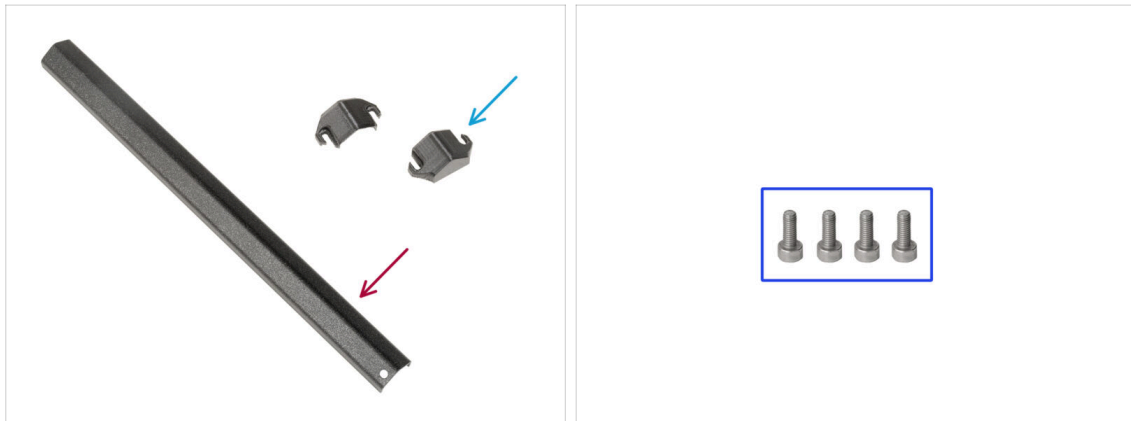

- **For the next step, please prepare:**
- Cover PSU cable (1x)
- PSU-cable-cover (2x)
- M3x8 screw (4x)

## STEP 15 PSU power cable cover: lower cover

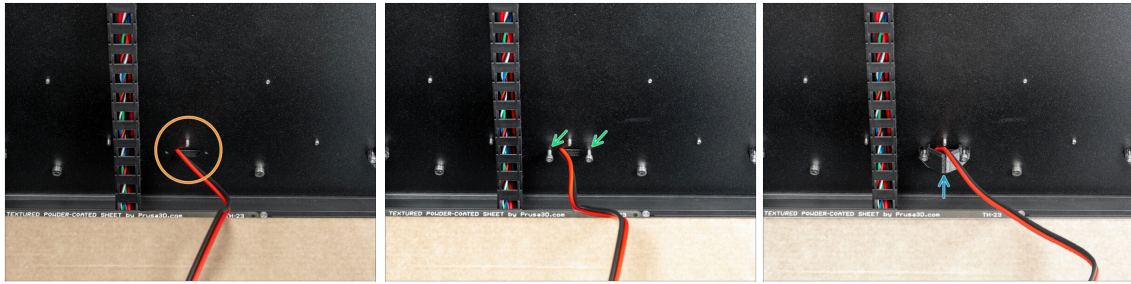

- ◆ Turn the printer, so the front side is facing you.
- ◆ Locate the hole with the power cable next to the heatbed cable bundle.
- ⓘ This part is a little bit tricky because of the manipulation space with the 2.5mm Allen key.
- ◆ Insert two M3x8 screws into the holes as described in the picture.
- ◆ Between the screws and back plate, insert a PSU-cable-cover. **Do not tighten the screws yet!**

## STEP 16 PSU power cable cover: power cable

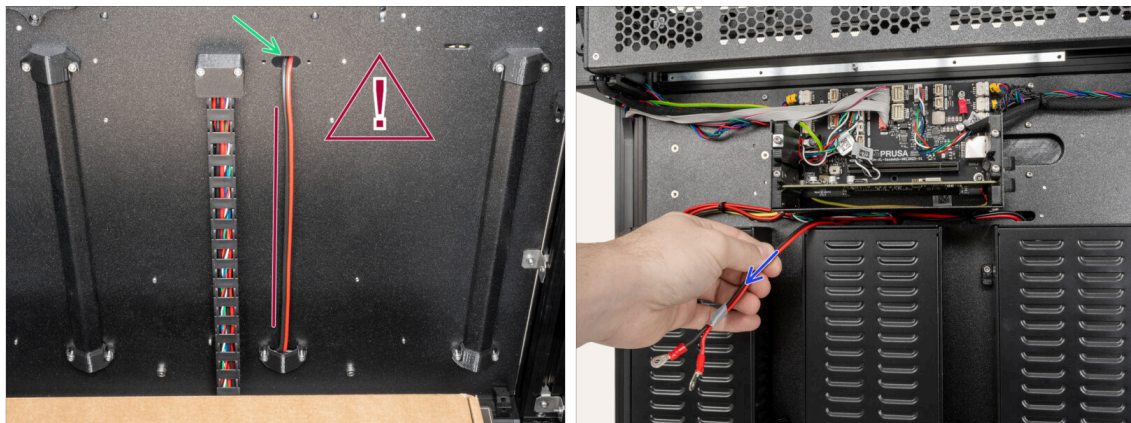

- ⚠ **Do not twist the cable.**
- ◆ Insert the power cable through the upper hole.
- ◆ From the back side of the printer, gently pull the power cable out.



### STEP 17 PSU power cable cover: middle cover

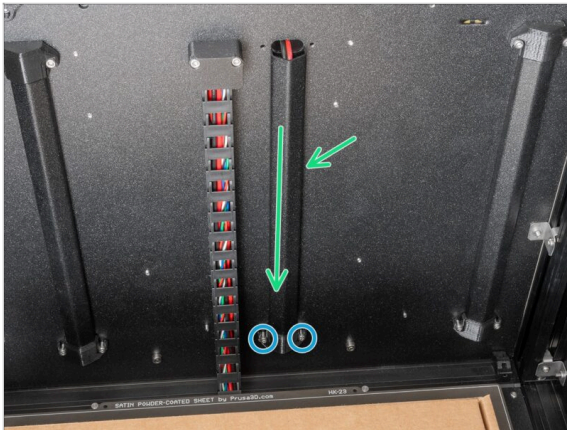

- Between the PSU-cable-cover and the back plate, insert the metal part.
- With the 2.5mm Allen key, tighten two M3x8 screws.

### STEP 18 PSU power cable cover: upper cover



- Insert two M3x8 screws into the back plate as described in the picture.
- Insert the PSU-cable-cover onto the screws.
- Tighten two M3x8 screws using a 2.5mm Allen key.

## STEP 19 XL-splitter: parts preparation



● For the next steps, please prepare:

- XL-splitter (1x)
- Terminal screws 6/32 (2x)

## STEP 20 Installing the XL\_splitter



- There are prepared guide grooves on the sides of the XL-buddy-box.
  - Using both hands, insert the XL-splitter into the slot in the XL-sandwich-board.
  - Take the power cable and turn it around the left side of the XL-buddy-box.
  - Place the black cable on the left terminal and secure it with the terminal screw.
  - Place the red cable on the right terminal and secure it with the terminal screw.
- ⚠ Note the correct orientation of the PE cable connector.

## STEP 21 Filament sensor cable: parts preparation

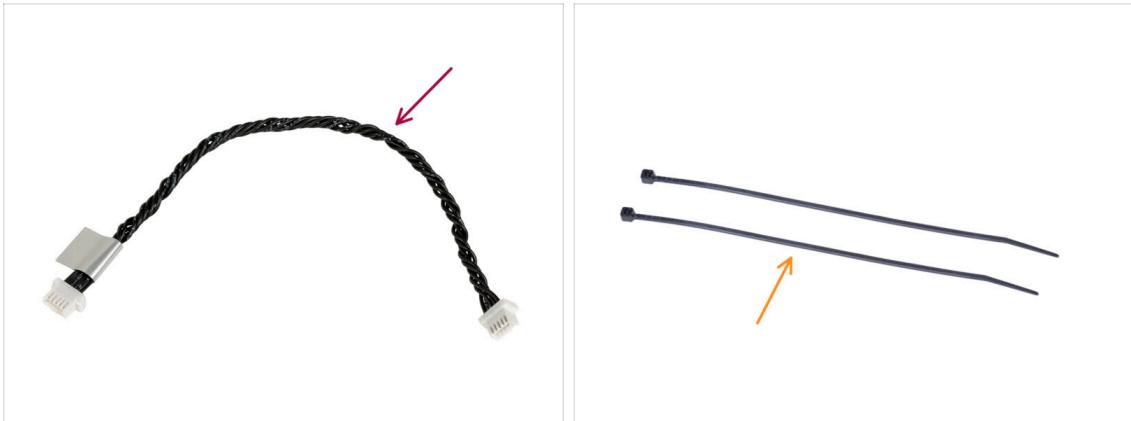

● For the next step, please prepare:

● Filament sensor cable (1x)

● Zip-ties (2x)

## STEP 22 Filament sensor cable: connecting the cable



● Locate the filament sensor cable connector on the left side of the XL-sandwich board.

● Plug one end of the filament sensor cable to the connector.

● Locate the perforations in the metal sheet for the zip-ties.

● Push two zip ties through the perforations in the metal sheet to secure all the cables guiding from the electronics box. Tighten them gently. Cut the excess of the zip ties.

ⓘ The black twisted cable is for the second filament sensor, which will be installed later in the next chapter.

● Good job! Now we can cover the cables.

## STEP 23 Metal plate cable covers: parts preparations

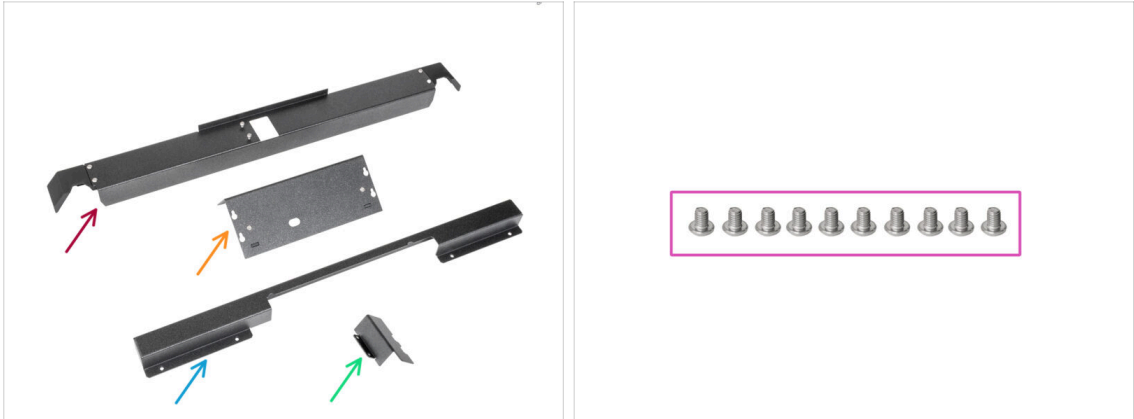

● For the next steps, please prepare:

- Rear-cable-management-upper (1x) you removed in the previous steps
- XL-buddy-box-cover (1x) you removed in the previous steps
- Rear-cable-management-lower (1x) you removed in the previous steps
- Rear-cable-management-base (1x) you removed in the previous steps
- M3x4rT screws (10x) you removed in the previous steps

## STEP 24 Adjusting the XL-buddy-box-cover

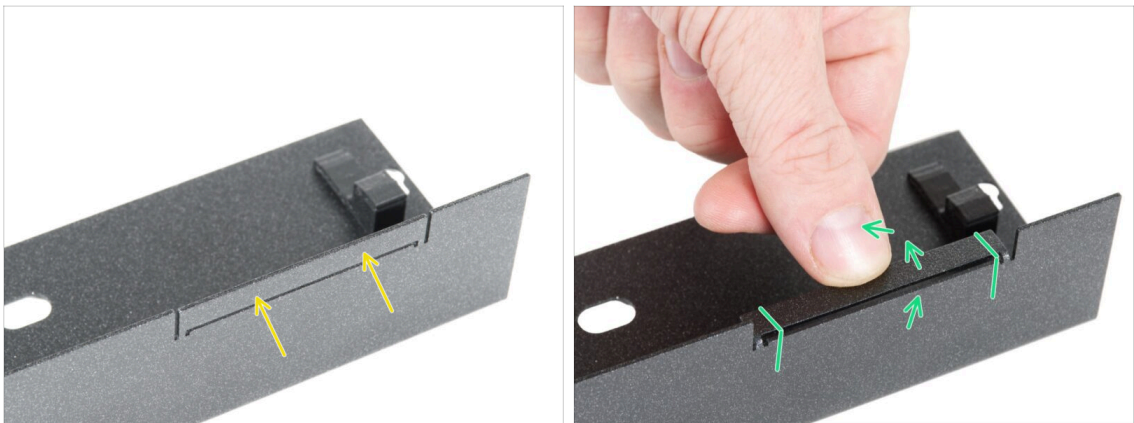



⚠ **CAUTION: Exercise caution as the sheets may have sharp edges.**

- Take the XL-buddy-box-cover and locate a rectangular cutout on it.
- According to the second picture, bend the cutout "inside" the cover. The sheet must be bent to 90 °.

## STEP 25 Lower metal plate cable covers





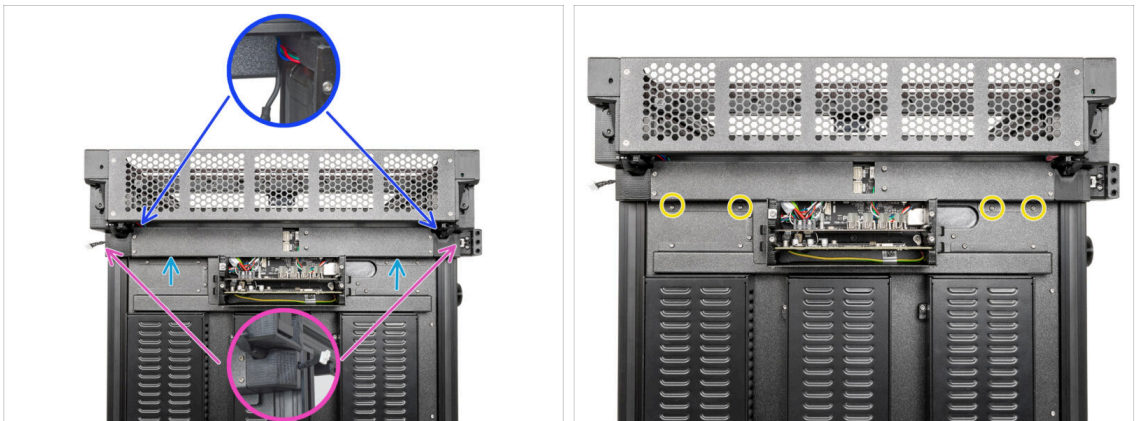

 **Do not pinch any cables!**

-  Gently attach the Rear-cable-management-lower and secure it with four M3x4rT screws using a T10 Torx key.
-  From the left side, attach the rear-cable-management-base and secure it with two M3x4rT screws using a T10 Torx key.

## STEP 26 Upper metal plate cable covers



-  Attach the Rear-cable-management-upper.
  -  Make sure that no cable is pinched in the plastic covers.
  -  Make sure that the metal cover does not pinch the motor cable.
-  Secure the rear-cable-management-upper with four M3x4rT screws using a T10 Torx key.

## STEP 27 XL buddy cover



- i In this step, temporarily cover the electronics. This is to protect the electronics during the installation of the tool heads in the following chapter. The electronics cover does not need to be tightened.
- ◆ Attach the XL buddy box cover to the screws on the electronics box. And slide it down to lock it on the screws.

## STEP 28 Reward yourself!

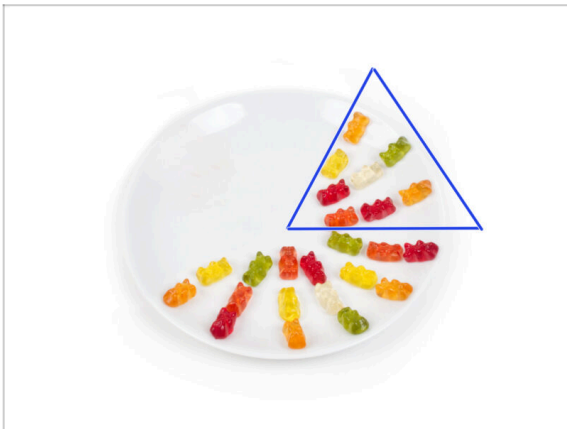

- ◆ Eat eight gummy bears.
- i **Did you know that** in 2014, a gummy bear-inspired emoji was added to the Unicode Standard, allowing gummy bear enthusiasts to express their love for the candy in digital conversations.

---

**STEP 29** Well done!



- ◆ Good job! The third PSU is attached. Let's go to the next chapter: **5. Extruder & accessories assembly**

## 5. Nextruder & accessories assembly





## STEP 1 Tools necessary for this chapter

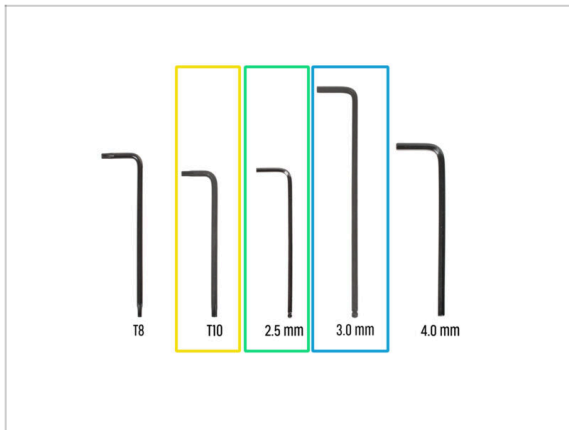

● For the next steps, please prepare:

- T10 Torx key
- 2.5 mm Allen key
- 3.0 mm Allen key

## STEP 2 Filament sensor: parts preparation



● For the following steps, please prepare:

- Side filament sensor assembly - right (1x)
- M3x10 screw (1x)
- M3nEs nut (1x)

### STEP 3 Right filament sensor



- From the right side of the printer:
- Insert the M3nEs nut into the extrusion.
- Connect the filament sensor cable to the filament sensor.
- Insert and tighten the M3x10 screw using a 2.5 mm Allen key.
- ⓘ You should now have both Side Filament sensors attached.

### STEP 4 Nextruder cable: parts preparation



- For the Nextruder cable bundle assembly please prepare:
- Cable bundle (5x)

## STEP 5 Nozzle seal versions

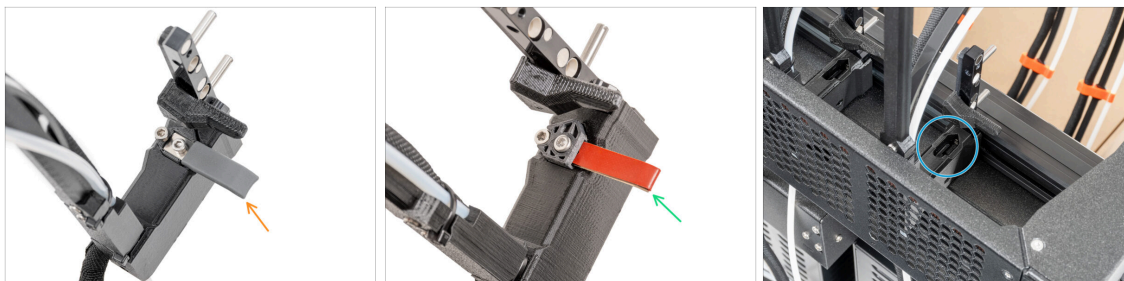

- i The latest assemblies come with the nozzle seal pre-installed on the extruder dock.
- ◆ To confirm this, examine one of the extruder docks closely and compare it to the picture to see if the nozzle seal is already in place with the square nut.
- ◆ Version A: grey nozzle seal - continue to the **Guiding the Nextruder cable**
- ◆ Version B: red nozzle seal - continue to the **Guiding the Nextruder cable**
- ◆ Version C: dock without the nozzle seal - **continue to the next step**

## STEP 6 Version C: preparing the dock



- ◆ **Repeat this step for all tool heads:**
  - ◆ Insert the M3nS nut into the nextruder dock.
  - ◆ Push the nut all the way into the dock. If not use the Allen key to push the nut into the nextruder dock.
- i If you didn't find the nut, there is a spare in the Nozzle Seal Assembly package.

## STEP 7 Guiding the Nextruder cable

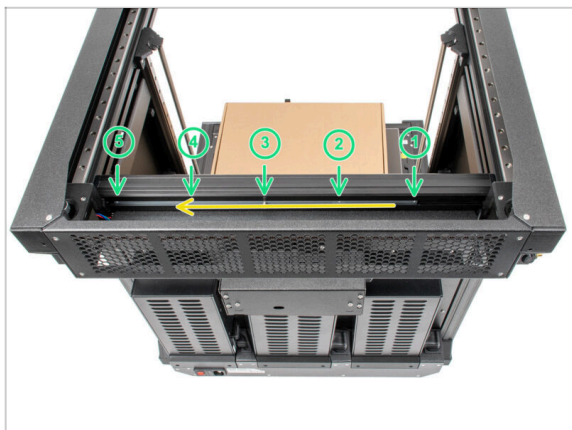

- Carefully turn the printer 180° so that the PSU (Power Supply Unit) side is towards facing you.
- Locate the long metal profile with five M3 holes inside the rear aluminium extrusion and push it to the left.
- We'll use all M3 holes in the metal profile.

⚠ **Maintain the position of the long metal profile for the next step. It must not move!**

## STEP 8 Attaching the Nextruder docks



- ⓘ This step is the same for all versions of the dock assembly.
- Take the cable bundle.
- Place the xl-dock-cable-router on the bottom metal sheet below the aluminum extrusion.
- There is a protruding screw from the xl-dock-cable-router. Attach the screw to the first screw hole on the long metal profile. Through the hole in the rear metal sheet, check if the cable holder is lined up with the hole.
- Push the 2.5 mm Allen key all the way through the hole in the rear metal sheet until you reach the **middle** screw in the xl-dock-cable-router and tighten the screw.
- ⓘ **The dock is a press fit, so the screw needs to be tightened very hard.**
- ⓘ **Attach all the remaining docks using the same procedure**

## STEP 9 Dock inspection

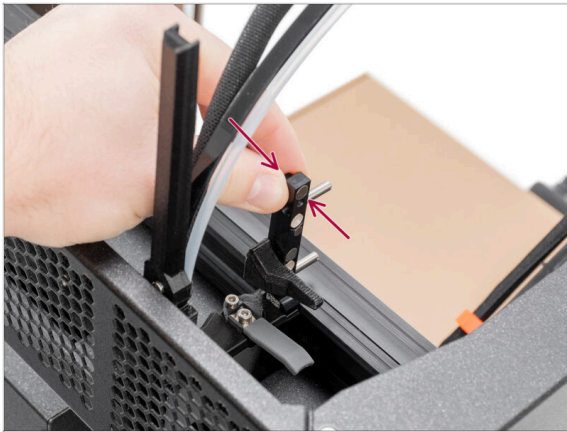

- ⓘ This step is the same for all versions of the dock assembly.
- ⚠ Check that the docks are properly tightened. **The dock must not move.**
- ⚠ **The dock is a press fit, so the screw needs to be tightened very hard.**
- ⬢ Please watch the video in the next step for a better understanding.

---

## STEP 10 Dock inspection: video

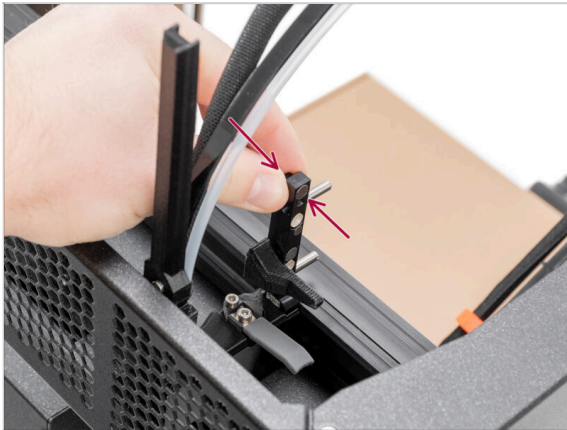

- ⬢ The following instructions need to be done correctly and carefully. Achieve better understanding and successful assembly by watching the video alongside the guide.

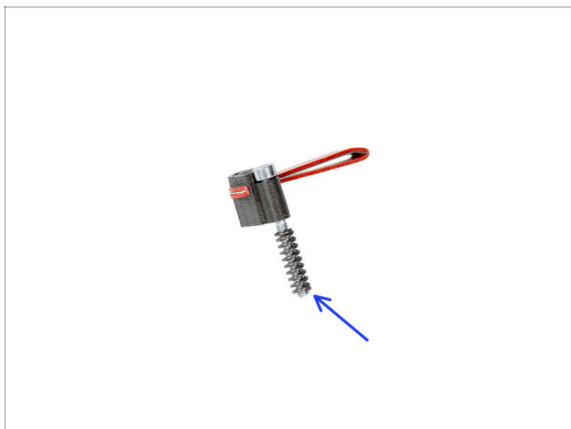
**STEP 11** Version C: Nozzle seal: parts preparation

- i Starting from May 2024, you may receive a gray nozzle seal. The assembly and functionality remain identical to the red one.
- ◆ **The following instructions are intended only for printers without pre-installed nozzle seals.** If you have already installed the nozzle seals on the Nextruder docks, go to [Connecting the Nextruder cables](#)
- ◆ **For the following steps, please prepare:**
  - ◆ Nozzle seal (2x)
- i The spring does not always have to be fitted on the nozzle seal. In this case, take the spring on the M3x30 screw in the nozzle seal. It is always included in the bag.

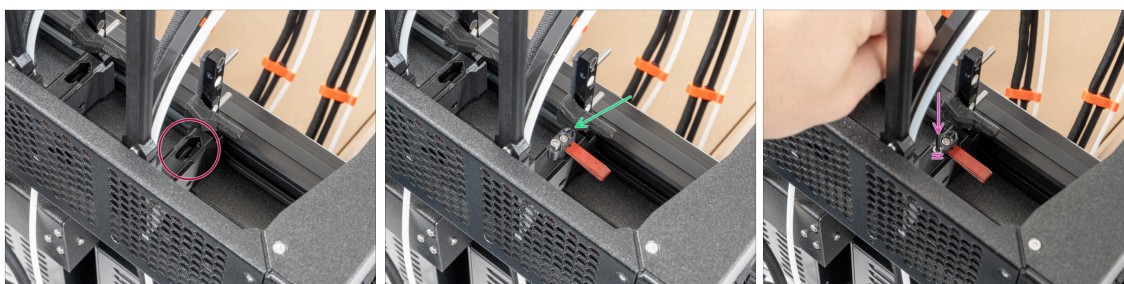
**STEP 12** Version C: Installing the Nextruder nozzle seal

- i **The current nozzle seal position is temporary, the exact height will be set later in this chapter.**
  - ◆ The docks have a hole for a nozzle seal.
  - ◆ Insert the nozzle seal (with the spring) into the dock.
  - ◆ Using a 2.5 mm Allen key, tighten the screw so that the head of the screw is 1 mm above the dock.
  - ◆ Good! The first dock is ready.
- i **Repeat this procedure for the second dock.**

## STEP 13 Connecting the Nextruder cables

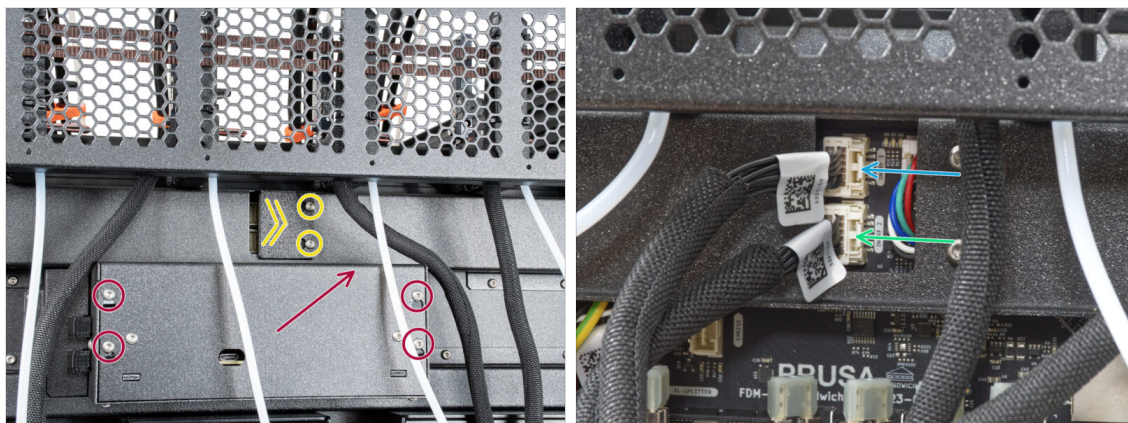

- Locate the xl-rear-cable-management-plug (cover) on the rear of the printer.
- Loosen two screws on the cover slightly. No need to remove them completely. Push the cover to the right and remove it from the printer.
- Loosen four screws securing the electronics cover. Remove the cover.
- Connect the first dock (from the right side) cable to the upper slot labeled DWARF 1.
- Connect the second dock (from the right side) cable to the lower slot labeled DWARF 2.

## STEP 14 Wi-fi antenna holder versions

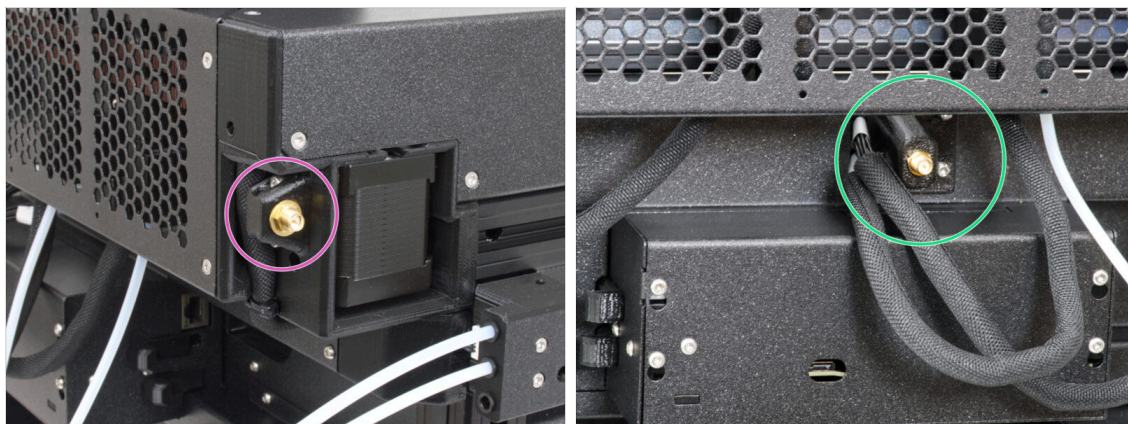

- The antenna connector is prepared by the manufacturer:
  - Version A: The Wi-fi antenna holder is on the side. **Continue to the step [Connecting the side Wi-Fi antenna](#)**
- The antenna connector has to be assembled by you:
  - Version B: The Wi-fi antenna is in the middle. **Continue to the next step.**

## STEP 15 Installing the rear Wi-Fi antenna holder

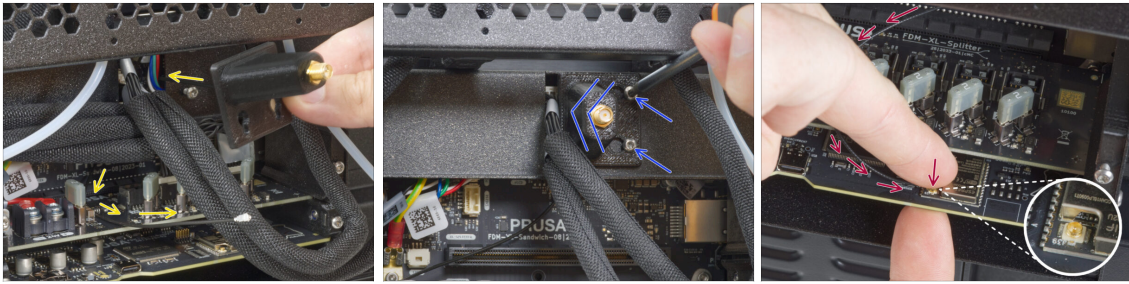

- i This step is only for the printer, which has a Wi-Fi antenna on the back of the printer. If you have the **antenna on the side** of the printer, **proceed to the next step**.
- Push the antenna cable through the opening in the cable cover (metal sheet) and guide it behind the cover to the electronics box.
- Attach the antenna-holder on the screws and push the cover to the left and tighten the screws.
- Connect the antenna to the appropriate slot on the XL Buddy board.

## STEP 16 Connecting the side Wi-Fi antenna

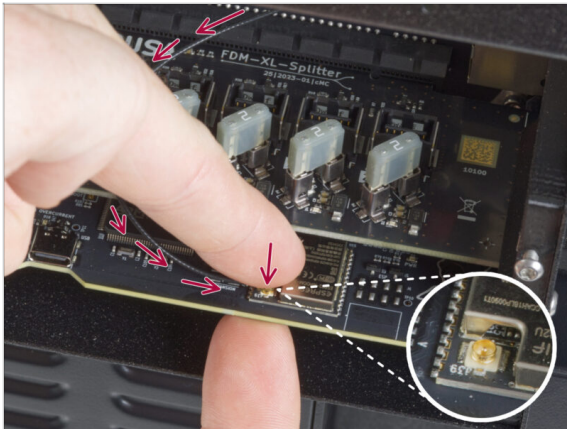

- Connect the antenna to the appropriate slot on the XL Buddy board.



## STEP 17 Connecting the Nextruder cables

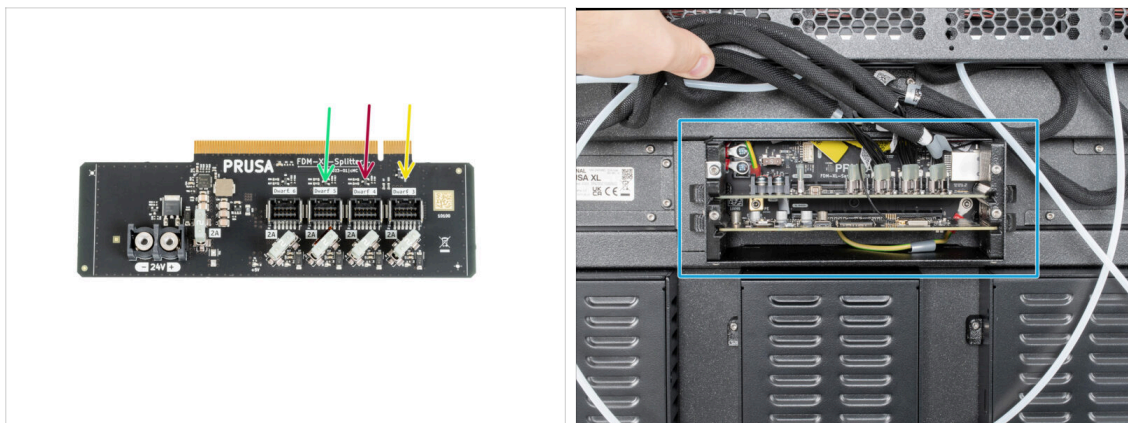

- i** Do not take the XL-splitter board out of the printer, the photo is only a tool for connecting the Nextruder cables.
- Connect the third, fourth and fifth (from the right) Nextruder to the splitter:
  - Third Nextruder.
  - Fourth Nextruder.
  - Fifth Nextruder.
- XL-splitter with connected Nextruders has to look like this.

## STEP 18 XL buddy box covering



- ⚠ Be carefull, do not pinch any cables!**
- Put the XL-buddy-box-cover back on the printer.
- Check Nextruders cables, they have to be inside the cutout in the cover.
- With a T10 key tighten the four screws.

## STEP 19 Guiding the docks PTFE tubes



- 🔴 Locate the right filament sensor.
- 🟢 Insert the **first** dock (from the right side) PTFE tube all the way into the **upper** hole in the part.
- 🟡 Insert the **second** dock (from the right side) PTFE tube all the way into the **middle** hole in the part.
- 🟣 Insert the **third** dock (from the right side) PTFE tube all the way into the **lower** hole in the part.

## STEP 20 Guiding the docks PTFE tubes



- 🔴 Locate the left filament sensor.
- 🟡 Insert the **fourth** dock (from the right side) PTFE tube all the way into the **upper** hole in the part.
- 🟣 Insert the **fifth** dock (from the right side) PTFE tube all the way into the **middle** hole in the part.

## STEP 21 Installing the Wi-Fi antenna: parts preparation



- ◆ For the following steps, please prepare:
- ◆ Wi-Fi antenna (1x)
- ⓘ The Original Prusa XL is shipped with two versions of the Wi-Fi antenna, each with a different shape. The functionality is the same.

## STEP 22 Installing the Wi-Fi antenna

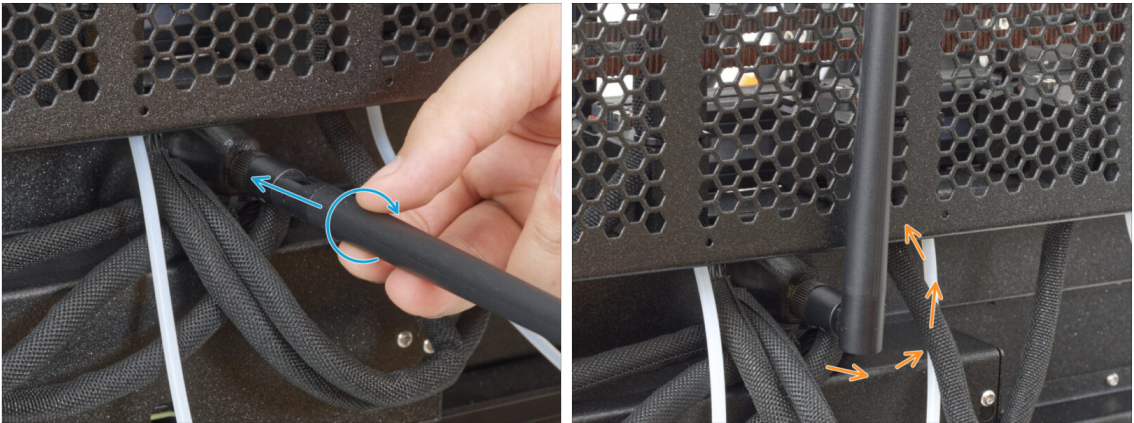

- ⓘ This step is only for the printer, which has a Wi-Fi antenna on the back of the printer.
- ◆ Locate the Wi-Fi antenna connector in the middle of the printer.
- ◆ Screw the Wi-Fi antenna on the antenna connector. The antenna can be rotated around and bent in two directions.
- ◆ We recommend pointing the antenna straight upwards.

## STEP 23 Spool holder: parts preparation



● For the following steps, please prepare:

- Spool-holder-slider (3x)
- Spool-holder-base (3x)
- M4x12 screw (3x)
- M4nEs nut (3x)

## STEP 24 Assembling the spool holder



● Repeat this step for all three spool holders:

- Locate pins two pins on the spool-holder-base and line them with the rails in the spool-holder-slider.
- Insert the spool-holder-base into the spool-holder-slider and push it through a little through the part.

**STEP 25** Preparing the spool holder

- 🟠 Insert the M4x12 screw on the longer side of the 3mm Allen key.
- 🟢 Insert the 3mm Allen key with the M4x12 screw through the assembled spool holder to the prepared hole in the spool-holder-base.
- 🟡 The M4x12 screw has to protrude through the spool-holder-base.

**STEP 26** Spool holder: left side

- ⬛ Carefully turn the printer so that the side with the filament sensor (**with 3 PTFE tubes**).
- 🟡 Insert the third M4nEs nut in the extrusion approximately to the same position as shown.
- 🟡 The M4nEs nuts are free to move, you can adjust the position as you want. But remember, the nuts must be slightly pushed in to smoothly move. Anyway, we recommend approximately the same position as you can see in the picture.
- 🟢 Attach and tighten the third spool holder to the M4nEs nut using a 4 mm Allen key. Note that there is a protrusion on the spool-holder-mount, which must fit into the groove in the extrusion.
- ⚠️ **Do not use the spool holder as a handle!**
- 📄 Keep in mind that if you mount the Spool holder too high or too low, it may not fit the filament spool on it. There has to be enough space around it.

**STEP 27** Spool holder: right side assembly

- Turn the printer, so the Filament sensor (with two PTFE tubes) is facing you.
  - Insert the fourth and fifth M4nEs nut in the extrusion approximately to the same position as shown.
  - The M4nEs nuts are free to move, you can adjust the position as you want. But remember, the nuts must be slightly pushed in to smoothly move. Anyway, we recommend approximately the same position as you can see in the picture.
  - Attach and tighten the fourth and the fifth spool holder to the M4nEs nut using a 3 mm Allen key. Note that there is a protrusion on the spool-holder-base, which must fit into the groove in the extrusion.
- ⚠ Do not use the spool holder as a handle!**
- i** Keep in mind that if you mount the Spool holder too high or too low, it may not fit the filament spool on it. There has to be enough space around it.

**STEP 28** Nextruder assembly: parts preparation

- For the next steps, please prepare:
  - Nextruder (5x)

## STEP 29 Docking the Nextruder

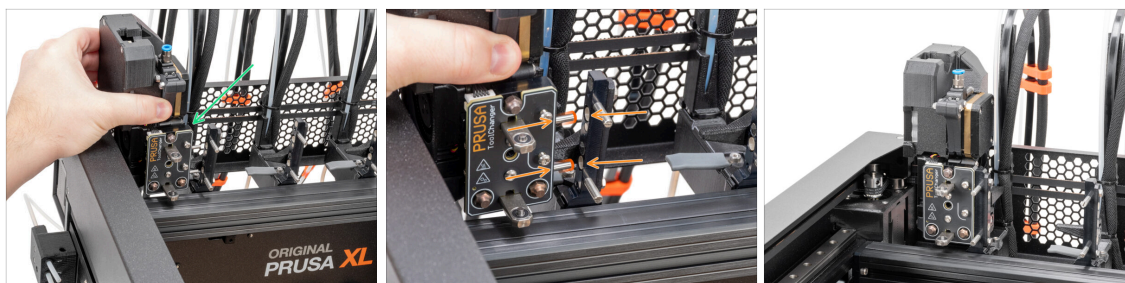

- Take the Nextruder and place it carefully next to the dock.
- Place the two metal inserts through the white holes in the dock. The magnets will help you dock the Nextruder.
- Well done, the first Nextruder is ready!
- Connect the **second, third, fourth and fifth** Nextruder in the same way as the first.

## STEP 30 Nextruder cable bundle assembly

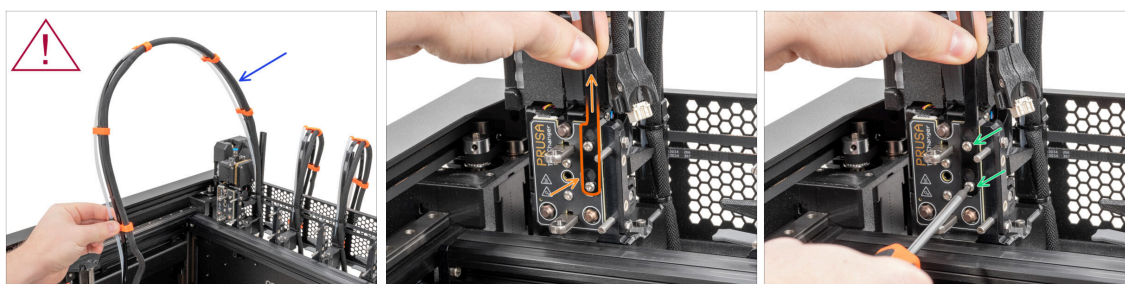

- **Repeat this step for all tool heads:**
  - Take the first dock Nextruder cable bundle.
  - ⚠ **Check that the cable bundle is not twisted!**
  - Hook up the keyhole openings in the flexible plate of the cable bundle onto the screw heads and push it up to correct the position.
  - Using a T10 key tighten the marked two screws.

## STEP 31 Nextruder cable bundle assembly

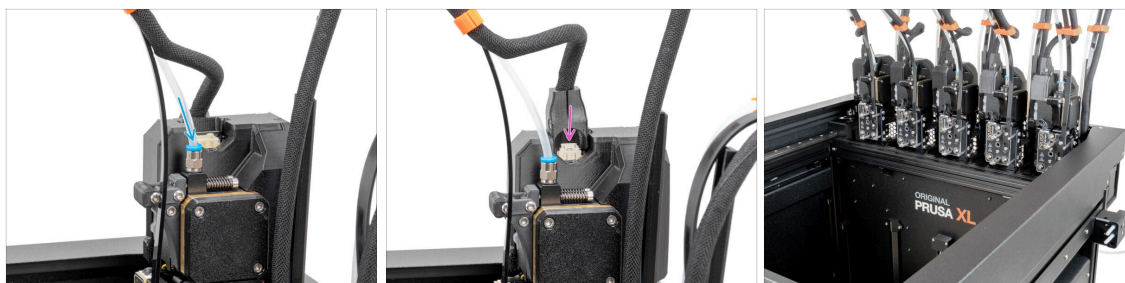

### Repeat this step for all tool heads:

- Insert the semi-transparent PTFE tube into the fitting on the Nextruder. Push it all the way in.
- Attach the cable connector into the top of the Nextruder.
- ⓘ Starting from September 2024, you may receive a new black Fitting M5-4. The assembly and functionality remain identical to the blue one.
- Assemble and connect all Nextruders.
- Good job!

## STEP 32 Nozzle seal height calibration

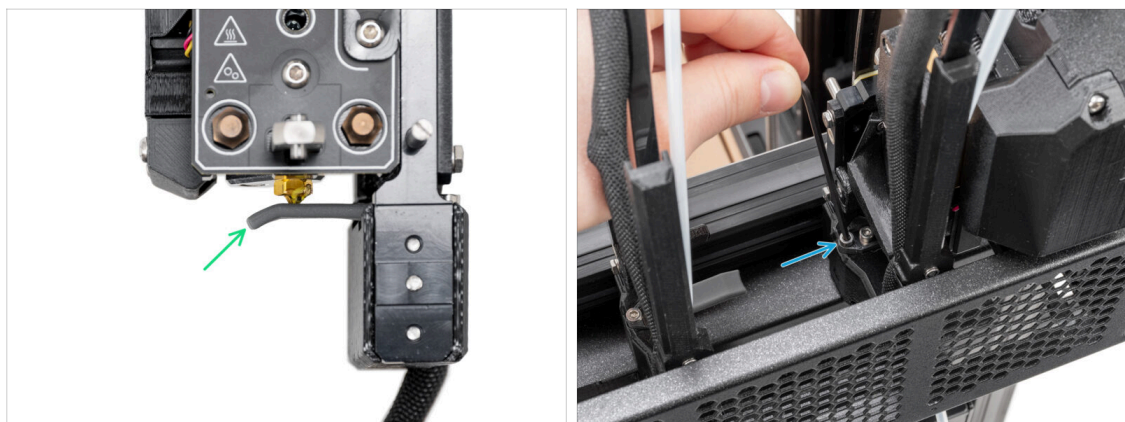

- ⓘ This step is the same for all versions of the dock assembly.
- ⓘ Starting from May 2024, you may receive a gray nozzle seal. The assembly and functionality remain identical to the red one.
- The following image was made with the Nextruder and dock removed from the printer for better visibility of how it should be set. **Please do not remove the docks from the printer and set the seal height with the dock still connected to the printer.**
- In the next step, we'll calibrate the height of the nozzle seal.
- Using the 2.5 mm Allen key, tighten or untighten the M3x30 screw to calibrate the height of the nozzle seal.
- Proceed to the next step.



## STEP 33 Nozzle seal height calibration



- If the Nozzle seal is too low or too high, we need to reposition its height.
- Using a 2.5 mm Allen key:
  - Turn the M3x30 screw clockwise to set the Nozzle seal lower.
- The correct position of the nozzle seal is when it isn't bent and is touching the nozzle.

## STEP 34 Haribo time!

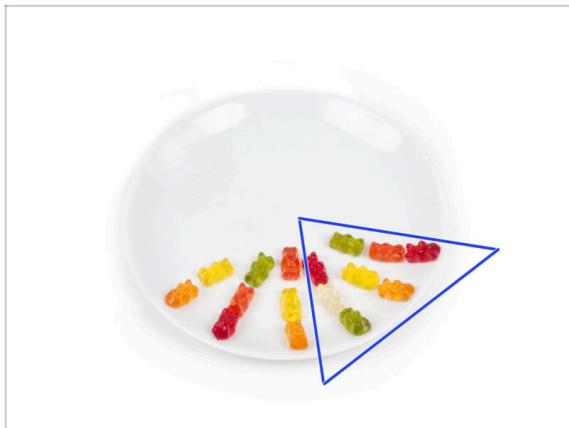

- Eat another eight gummy bears.
- ⓘ **Did you know that** the bright colors of gummy bears are achieved through the use of food coloring, which adds to their visual appeal.

## STEP 35 Remaining fasteners



◆ To avoid the concern of having leftover nuts and screws, refer to the following list of fasteners that should remain unused from the initial package upon completing the assembly.

ⓘ Note that if you have used any spare, the final count may vary.

◆ **Remaining fastener items:**

- Terminal screw (1x)
- M3x6 (1x)
- M3x8 (1x)
- M3x10 (2x)
- M3x12 (1x)
- M3x20rT (2x)
- M4x12 (1x)

## STEP 36 Almost done!



◆ **Congratulation!** Your Original Prusa XL is ready to be fired up!

◆ Compare the final look with the picture.

◆ Now, let's go to the last chapter **6. First run.**

## 6. First run



## STEP 1 Before you start with Multi-Tool



- ❗ This chapter shows a brief description of the wizard. Please note that the screenshots are illustrative and might differ from those in the firmware.
- ❗ Make sure you are running **Firmware 4.7.0 or newer**
  - ❗ You can download firmware updates in [Downloads](#). The guide for updating the firmware is in [How to update firmware \(MK4/XL\)](#).
- ❗ Some parts of the wizard must be done multiple times, this depends on the number of tool-heads. For example:
  - ◆ Dock Calibration
  - ◆ Loadcell calibration
  - ◆ Filament sensor calibration

## STEP 2 Preparing the printer



- ⚠ Make sure that the printer is placed in a stable place where no ambient vibrations are transmitted (for example, where other printers are printing).
- ◆ From the rear side of the printer, plug in the PSU cable.
- ◆ Turn the power switch ON (symbol "I").

### STEP 3 Factory reset



- After upgrading, the first thing we need to do is reset the printer to factory defaults.
- On the printer screen, go to *Settings* -> *System* -> *Factory reset* and select *Reset Settings & Calibrations*.
- Wait till the printer is ready.
- Restart the printer.
- Select the language you prefer.
- Good job. The printer is ready for Wizzard. Proceed to the next step.

### STEP 4 Prusa Nextruder sock (Optional)



- A silicone sock is supplied with each Nextruder package.
- If you want to install the sock, **do it before the calibration.**
- **i** How to install the sock - [check the article.](#)

## STEP 5 Wizard



- After the printer starts up, the screen prompts for the printer test and setup wizard.
- ❗ The wizard will test all important components of the printer. The whole process takes a few minutes. Some parts of the wizard require direct user interaction. Follow the instruction on the screen.
- ⚠ **NOTE: While testing the axes, make sure that there is nothing in the printer that is obstructing the movement of the axes.**
- ⚠ **WARNING: Do not touch the printer during the wizard unless prompted! Some parts of the printer may be HOT and moving at high speed.**

## STEP 6 Wizard: Dock Position Calibration

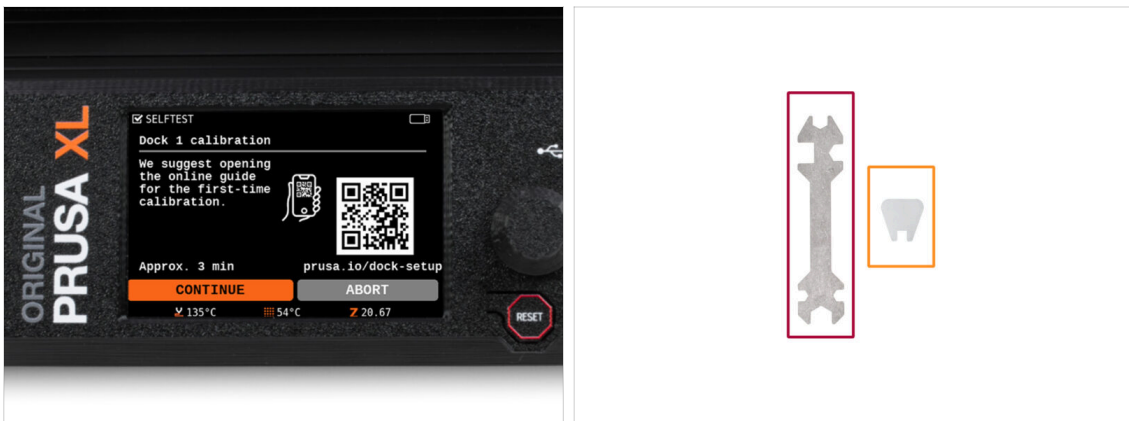

- Dock calibration will guide you through how to properly calibrate the position of individual tool heads on the printer.
- **For this procedure, please prepare:**
  - Universal wrench (1x)
  - Mini wrench (1x)
- ⚠ **It is necessary to follow every step in the dock calibration properly! Do not rush, read every step twice, then proceed with the instruction.**

## STEP 7 Wizard: Loosen pin

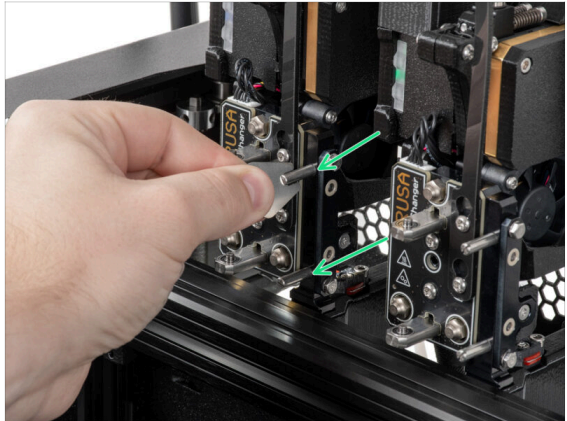

- Follow the wizard instructions on the screen.
- Using a Mini wrench, unscrew and remove both dock pins on Dock 1.

## STEP 8 Wizard: Loosen screws

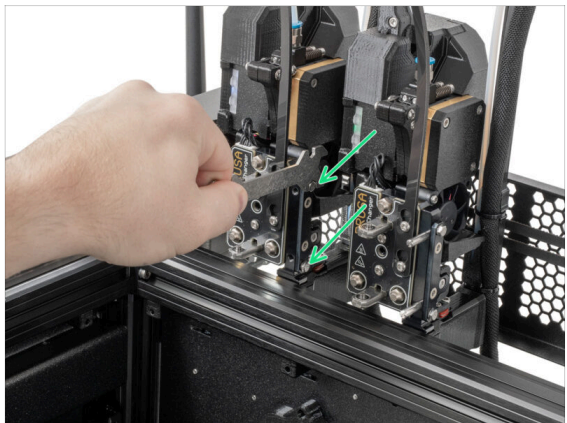

- Follow the wizard instructions on the screen.
- Using a Uni wrench, loosen two screws. **A few turns are enough.**

## STEP 9 Wizard: Lock the tool

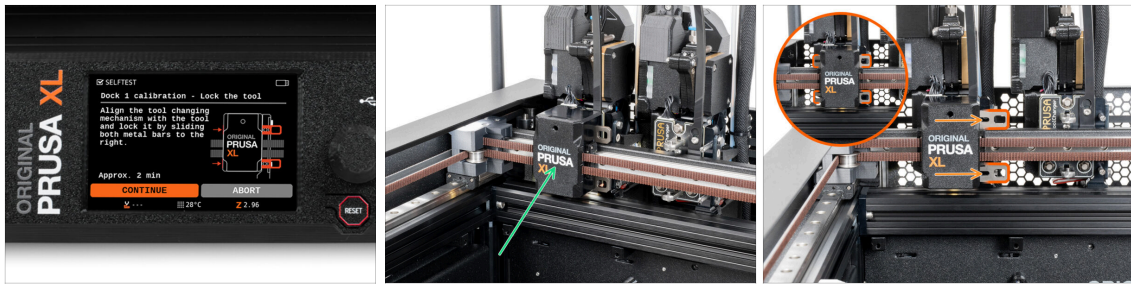

- Follow the wizard instructions on the screen.
- Manually move the Tool changing mechanism to the first tool.
- Manually lock the metal bars as described in the picture.
- ⚠ **The tool has to be locked in the tool changer.**

## STEP 10 Wizard: Tighten the upper screw



- Follow the wizard instructions on the screen.
- Using a Uni wrench, tighten the upper screw on a side of the dock.
- ⚠ **After confirming by the *continue* button on the LCD, the XY axis will leave the dock with the tool. Clear the space.**



## STEP 11 Wizard: Tighten the lower screw

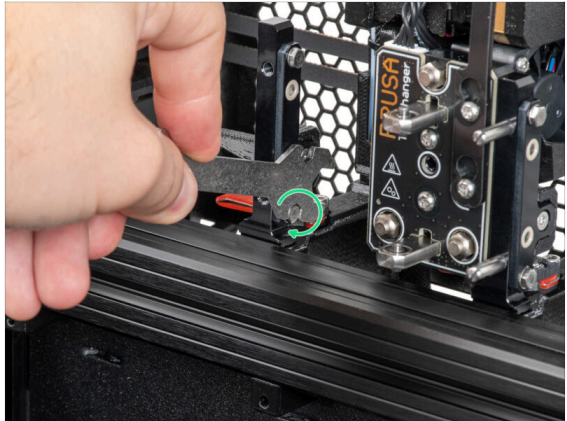

- Follow the wizard instructions on the screen.
- Using a Uni wrench, tighten the lower screw on a side of the dock.

## STEP 12 Wizard: Install pins

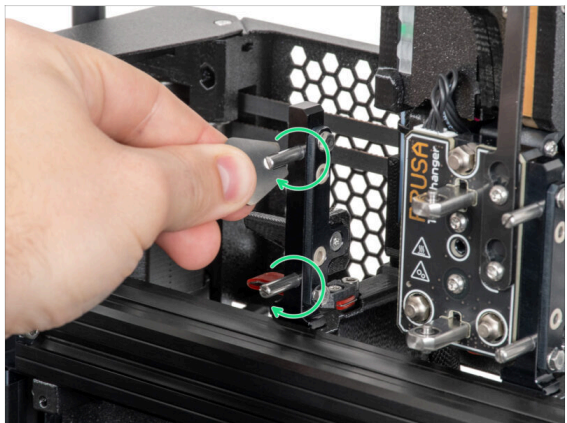

- Follow the wizard instructions on the screen.
- Insert the two metal pins and tighten them with a Mini wrench.
- After clicking on the *continue* button on the LCD, the printer will put back the tool into the dock1 and do a few calibration moves.
- After the Dock1 calibration, proceed to the Dock2 calibration and repeat the steps.

## STEP 13 Wizard: Dock successfully calibrated

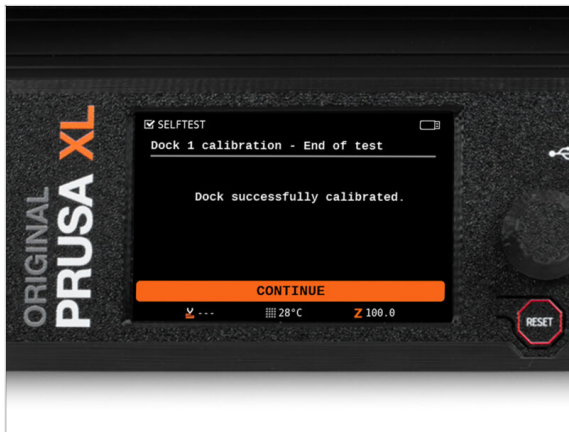

- ◆ Good job! The Dock1 is calibrated.
- ◆ According to the number of print heads, the dock calibration process is repeated.

## STEP 14 Wizard: Test Loadcell



- ◆ The next step of the wizard will prompt you to touch the nozzle to test and calibrate the **Loadcell**. During this procedure, the parts of the printer are not heated, you can touch the parts of the printer. Click on **Continue**.
- ◆ Do not touch the nozzle yet, wait until prompted with the message: **Tap the nozzle NOW**.
- ◆ Slightly tap the nozzle. No need to use extra force. In case the Loadcell does not detect enough touch, you will be prompted to repeat the step. Otherwise, you will see **Loadcell test passed OK** when it succeeds.

## STEP 15 Wizard: Recalibrate Filament Sensors

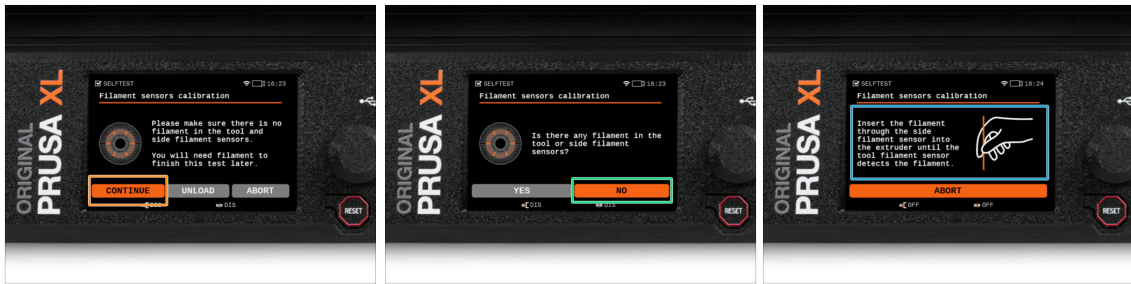

- ◆ After the upgrade, we need to recalibrate the filament sensors.
- ❗ Your printer should have no filament at all.
- ◆ Please proceed through the filament inserted calibration. Follow the instructions on the display.
- ◆ Select **NO**, your printer has no filament at all.
- ◆ Wait for the printer to prompt you to insert the filament into the side filament sensor.
- ◆ Proceed to the next step.

## STEP 16 Wizard: Recalibrate Filament Sensors



- ◆ Now, insert the filament into the PTFE tube (the tool head you selected) in the side filament sensor and push it until it reaches the filament sensor in the extruder (you will feel a slight resistance).
- ◆ You can check the side filament sensor (left) and extruder filament sensor (right) status on the bottom bar on the screen.
- ❗ It takes several seconds for the filament sensor to be calibrated.
- ◆ After the successful calibration, proceed on the screen by selecting **Continue**.
- ◆ Proceed to the next step.

## STEP 17 Wizard: Recalibrate Filament Sensors



- 🟠 You will be prompted to remove the filament from the side filament sensor.
- 🟢 Remove completely the filament from the side filament sensor.
- 🟡 On the screen, select **Finish** and proceed with the calibration with all tool heads on your printer.

## STEP 18 Calibration pin: parts preparing

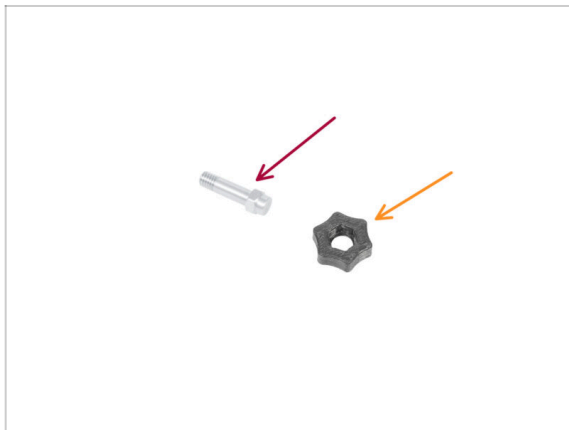

🟡 For the next step, please prepare:

- 🟢 Calibration pin (1x)
- 🟠 Calibration-pin-key (1x)

## STEP 19 Calibration pin: parts assembly

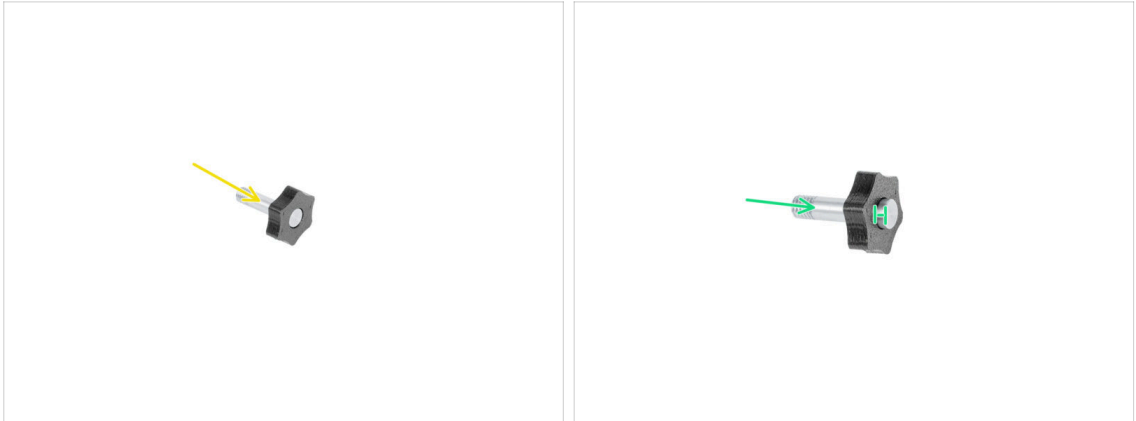

- Insert the calibration pin into the plastic part.
- Push the pin into the plastic part, so it will make a small gap on top.
- Well done, the pin is prepared.

## STEP 20 Wizard: Tool Offset Calibration

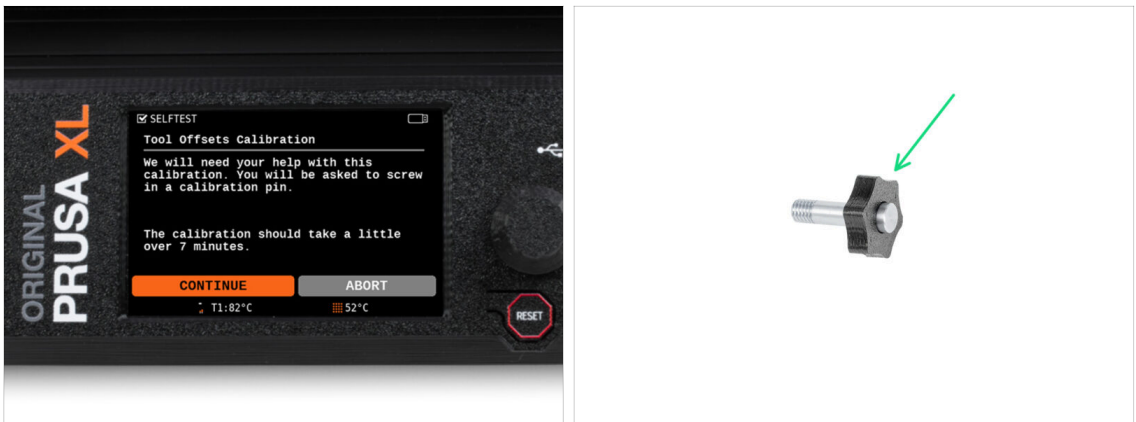

- During offset calibration, you will need to screw the calibration pin into the center of the heatbed.
- Click on *Continue* to start the Tool Offsets Calibration.
- Calibration pin (1x)

## STEP 21 Wizard: Sheet install



- ◆ Follow the wizard instructions on the screen.
- ◆ Put the print sheet on a heatbed.
- ⓘ Now, the printer starts short calibration.

## STEP 22 Wizard: Calibration pin installation

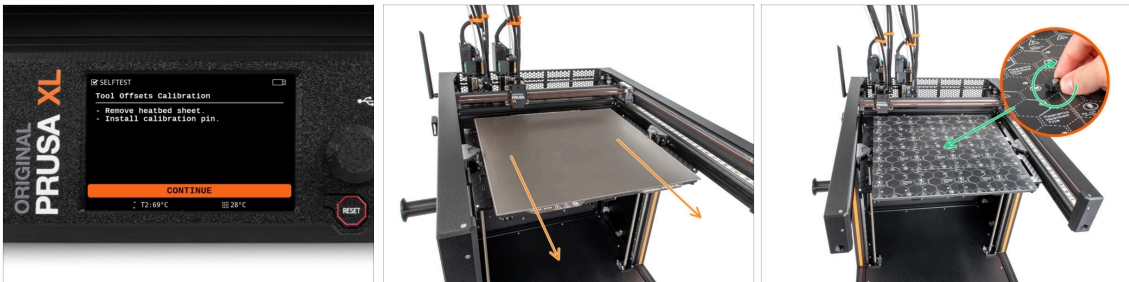

- ◆ Follow the wizard instructions on the screen.
- ◆ Take off the print sheet from the heatbed.
- ◆ Install the calibration pin into the middle of the heatbed. Turn the pin clockwise.
- ⓘ Now, the printer will calibrate all five tool heads.

## STEP 23 Wizard: Offset calibration done



- ◆ Follow the wizard instructions on the screen.
- ◆ Untighten the calibration pin from the heatbed and take it off. Rotate counterclockwise.
- ◆ Place the print sheet onto the heatbed.
- ◆ (i) The printer will finish the calibration.
- ◆ Good job! The Offset calibration is done.

## STEP 24 Calibration pin



- ◆ Insert the calibration pin into the side filament sensor.

## STEP 25 It's done

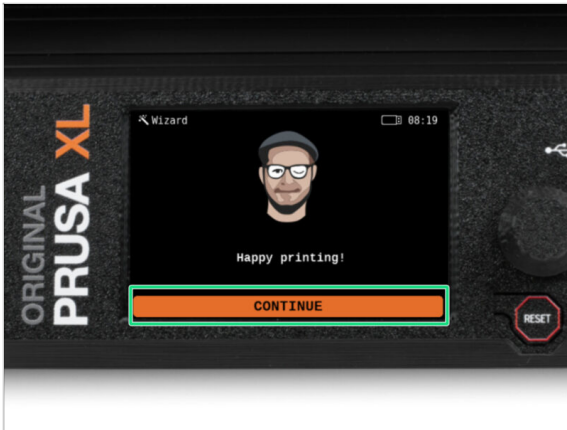

- ◆ **That's all, the printer is ready to print.** But still, follow the instructions in this manual to the end.

## STEP 26 Reward yourself!



- ◆ It looks like you have successfully assembled and connected everything. No doubt ;). **Congratulations!** You deserve a big reward for that. Eat all the remaining gummy bears... and don't forget to share with those who supported you during the assembly.
- ⓘ **Did you know that** Haribo gummy bears are one of the most important parts of the Original Prusa printers assembly instructions.



## STEP 27 Checking the Heatbed installation (Semi-Assembled printer)



- i** This step is intended only for the semi-assembled printer version. If you have an assembled version, skip this step.
- In this step, we will make sure the Heatbed is installed correctly
  - Using the T10 screwdriver, slightly loosen all screws on the sides of the bed-frame. **A few turns are enough.**
  - Visit the menu **Control > Move Axis** and adjust the **Move Z** value to the lowest position.
  - Leave the heatbed for a few seconds until it settles in the lowest position.
  - While in the lowest position, tighten all screws using the T10 screwdriver.

## STEP 28 Quick guide for your first prints



- 📌** Now, please read the **3D Printing Handbook**, which is tailor-made for your printer and **follow the instructions to set up the printer properly**. The latest version is always available at [this link](#).
- ⚠️** Read the chapters *Disclaimer* and *Safety instructions*.

## STEP 29 Printable 3D models

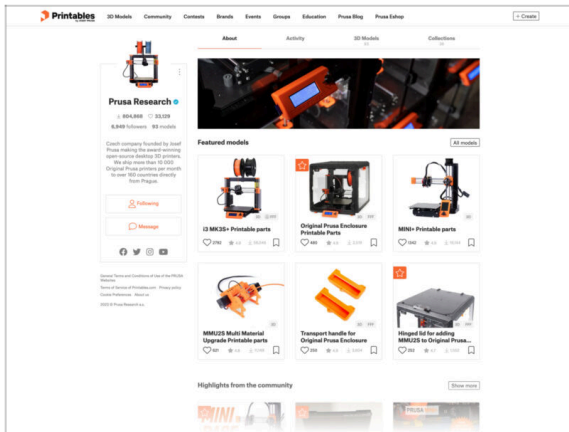

- ◆ Congratulations! You should be ready to print by now ;-)
- ◆ You can start by printing some of our test objects bundled on the included USB stick - you can check them out [Printables](#).

## STEP 30 Prusa knowledge base

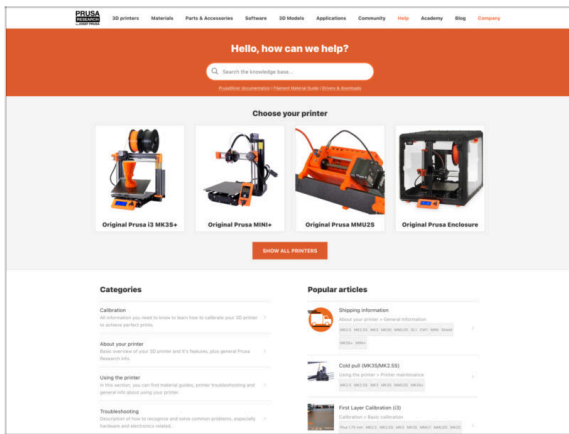

- ◆ If you encounter any problems at all, don't forget you can always check out our knowledge base at [help.prusa3d.com](http://help.prusa3d.com)
- ◆ We're adding new topics every day!

## STEP 31 Join Printables!

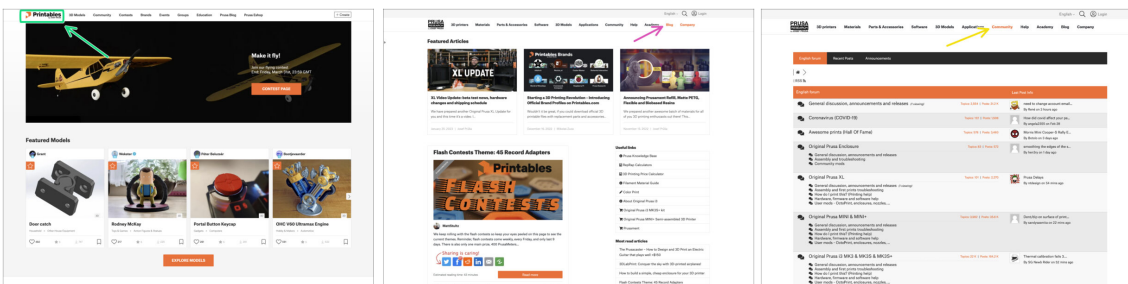

- ◆ Don't forget to join the biggest Prusa community! Download the latest models in STL or G-code tailored for your printer. Register at [Printables.com](http://Printables.com)
- ◆ Looking for inspiration on new projects? Check our blog for weekly updates.
- ◆ If you need help with the build, check out our forum with a great community :-)
- ◆ All services share one account.

# Manual changelog XL (Dual-Head to Five-Head upgrade)

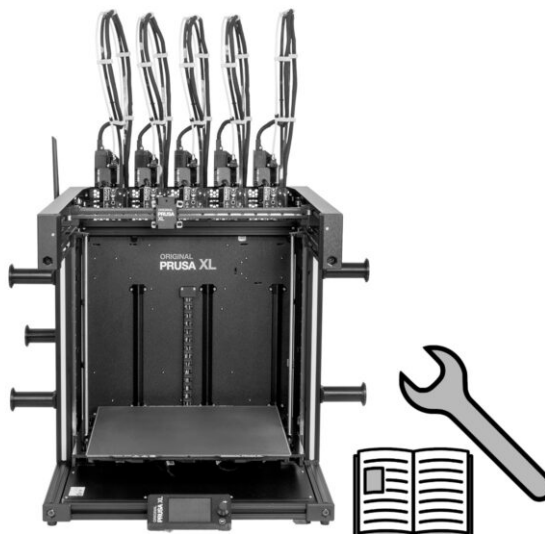

## STEP 1 Version history

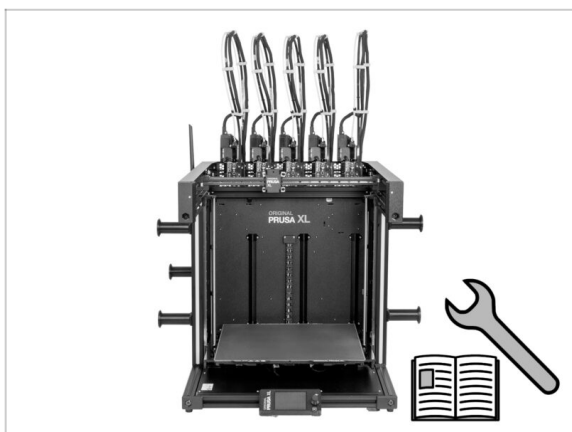

- Versions of the Original Prusa XL Double-head to Five-head upgrade manual:
- 01/2024 - Initial version 1.00
- 05/2024 - Updated to version 1.01

---

## STEP 2 Changes to the manual (1)

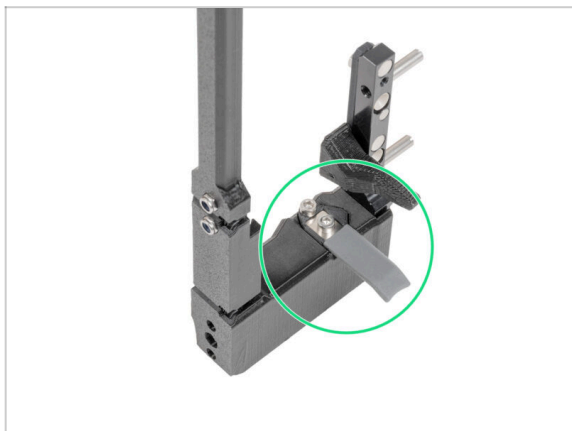

- 05/2024
  - Added information about the new gray nozzle seal.
- Manual version 1.01

**Notes:**

---

---

---

---

---

---

---

---

---

---

---

---

---

---

---

---

---

---

---

---

---

---

---

---

---

---

---

---

---

---





---









