

Indice

| | |
|---|----|
| 1. Introduction & preparation | 7 |
| Passo 1 - Come navigare nel manuale | 8 |
| Passo 2 - Visualizza immagini ad alta risoluzione | 8 |
| Passo 3 - Before you begin | 9 |
| Passo 4 - Tutti gli utensili necessari sono inclusi | 10 |
| Passo 5 - Labels guide | 11 |
| Passo 6 - Spare bag | 11 |
| Passo 7 - Parti stampate - versione | 12 |
| Passo 8 - Siamo qui per te! | 13 |
| Passo 9 - Pro tip: inserire i dadi | 14 |
| Passo 10 - Important: Electronics protection | 15 |
| Passo 11 - Datti una ricompensa | 16 |
| Passo 12 - Come completare l'assemblaggio correttamente | 17 |
| Passo 13 - Prepare your desk | 18 |
| Passo 14 - Important information - Buddy3D camera | 18 |
| Passo 15 - Firmware Info | 19 |
| Passo 16 - Spostare l'asse Z | 19 |
| Passo 17 - Unloading filament | 20 |
| Passo 18 - Preparing the printer | 20 |
| 2. Printer disassembly | 21 |
| Passo 1 - Attrezzi necessari per questo capitolo | 22 |
| Passo 2 - Important information - removed parts | 22 |
| Passo 3 - Removing the top nylon rivets | 23 |
| Passo 4 - Rimuovere il pannello superiore | 23 |
| Passo 5 - Removing the top profile | 24 |
| Passo 6 - Removing the door | 24 |
| Passo 7 - Accesso all'elettronica | 25 |
| Passo 8 - Come accedere alla Buddy Board | 25 |
| Passo 9 - Unplugging the cable I. | 26 |
| Passo 10 - Unplugging the cables II. | 26 |
| Passo 11 - Removing the cables | 27 |
| Passo 12 - Pushing the cables in | 27 |
| Passo 13 - Guiding the heatbed cables in | 28 |
| Passo 14 - Sganciare il cavo principale | 28 |
| Passo 15 - Removing the LoveBoard cover | 29 |
| Passo 16 - Disconnecting the Nextruder cables - left | 29 |
| Passo 17 - Disconnecting the Nextruder cables - top | 30 |
| Passo 18 - Disconnecting the Nextruder cables - right | 30 |
| Passo 19 - Scollegare il tubo in PTFE | 31 |
| Passo 20 - Removing the Nextruder fitting | 31 |
| Passo 21 - Removing the Nextruder | 32 |
| Passo 22 - Rimuovere la ventola di stampa | 32 |
| Passo 23 - Rimuovere la LoveBoard | 33 |
| Passo 24 - Removing the fan shroud | 33 |
| Passo 25 - Removing the side handle | 34 |
| Passo 26 - Removing the side filament sensor | 34 |
| Passo 27 - Rimozione del porta bobina | 35 |
| Passo 28 - Riepilogo parti I. | 35 |
| Passo 29 - Parts recap II. | 36 |
| Passo 30 - È l'ora delle Haribo! | 36 |

| | |
|---|-----------|
| Passo 31 - Final step | 37 |
| 3. Aggiornamento dell'asse Z | 38 |
| Passo 1 - Attrezzi necessari per questo capitolo | 39 |
| Passo 2 - Optional: Installing the Buddy3D Camera USB-C cable | 39 |
| Passo 3 - Rimozione del coperchio del cavo del piano riscaldato | 40 |
| Passo 4 - Releasing the heatbed | 40 |
| Passo 5 - Rimuovere il piano riscaldato | 41 |
| Passo 6 - Removing the bed spacer | 41 |
| Passo 7 - Spessori piano riscaldato: preparazione componenti | 42 |
| Passo 8 - Assembling the INDX-bed-spacer-rear | 42 |
| Passo 9 - Montaggio del INDX-bed-spacer-rear | 43 |
| Passo 10 - Inserting the spacer - left | 43 |
| Passo 11 - Securing the bed spacer - left | 44 |
| Passo 12 - Inserting the spacer - right | 44 |
| Passo 13 - Securing the bed spacer - right | 45 |
| Passo 14 - Offset sensor: parts preparation | 45 |
| Passo 15 - Mounting the INDX OffsetSensor | 46 |
| Passo 16 - Connecting the offset sensor cable | 46 |
| Passo 17 - Securing the offset sensor assembly | 47 |
| Passo 18 - Guiding the offset sensor cable | 47 |
| Passo 19 - Securing the offset sensor cable | 48 |
| Passo 20 - Removing the Bed-cable-cover-bottom | 48 |
| Passo 21 - Heatbed cable covers: parts preparation | 49 |
| Passo 22 - Heatbed cable covers: parts preparation II | 49 |
| Passo 23 - Assemblare la copertura Bed-cable-cover-bottom | 50 |
| Passo 24 - Inserimento del piano riscaldato | 50 |
| Passo 25 - Securing the heatbed | 51 |
| Passo 26 - Avvolgere i cavi del piano riscaldato | 51 |
| Passo 27 - Coprire i cavi del piano riscaldato | 52 |
| Passo 28 - Guiding the heatbed cable bundle I. | 52 |
| Passo 29 - Guiding the heatbed cable bundle II. | 53 |
| Passo 30 - Fissare la guaina in tessuto | 53 |
| Passo 31 - Removing the Bed-stop-rear | 54 |
| Passo 32 - INDX-C1-Bed-stop-rear: parts preparation | 54 |
| Passo 33 - Assembling the Bed-stop-rear | 55 |
| Passo 34 - Installing the new Bed-stop-rear | 55 |
| Passo 35 - Assicurare il Bed-stop-rear | 56 |
| Passo 36 - Connecting the RGB LED + offset sensor cables | 56 |
| Passo 37 - Collegamento dei cavi del piano riscaldato | 57 |
| Passo 38 - Haribo time | 57 |
| Passo 39 - Fatto | 58 |
| 4. INDX Toolhead & Side filament sensors | 59 |
| Passo 1 - Attrezzi necessari per questo capitolo | 60 |
| Passo 2 - Loosening the belts | 61 |
| Passo 3 - Rilascio delle cinghie | 61 |
| Passo 4 - Gantry aligner tool: parts preparation | 62 |
| Passo 5 - Installing the Gantry-aligner-tool - right | 62 |
| Passo 6 - Installing the Gantry-aligner-tool - left | 63 |
| Passo 7 - Allineamento della guida lineare | 63 |
| Passo 8 - Removing the Gantry-aligner-tool | 64 |
| Passo 9 - Print head mount: parts preparation | 64 |
| Passo 10 - Securing the belts | 65 |
| Passo 11 - Installing the Head-mounting-plate | 65 |
| Passo 12 - Regolazione delle cinghie | 66 |

| | |
|---|----|
| Passo 13 - INDX Toolhead assembly: Parts preparation | 66 |
| Passo 14 - Attaching the cable strain relief | 67 |
| Passo 15 - INDX Toolhead: parts preparation | 67 |
| Passo 16 - Mounting the INDX Toolhead | 68 |
| Passo 17 - Fan shroud: preparazione dei componenti | 68 |
| Passo 18 - Attaching the Fan-shroud | 69 |
| Passo 19 - Inserting the nut | 69 |
| Passo 20 - Ventola di stampa: preparazione dei componenti | 70 |
| Passo 21 - Installing the print fan | 70 |
| Passo 22 - Connettere la ventola di stampa | 71 |
| Passo 23 - INDX head cable: parts preparation I. | 71 |
| Passo 24 - INDX head cable: parts preparation II. | 72 |
| Passo 25 - Guiding the head cable | 72 |
| Passo 26 - Inserting the Nylon | 73 |
| Passo 27 - Connecting the head cable | 73 |
| Passo 28 - Attaching the head cable | 74 |
| Passo 29 - Securing the swing arm clip | 75 |
| Passo 30 - Securing the main cable | 75 |
| Passo 31 - Installing the Head cable clip | 76 |
| Passo 32 - Connecting the head cable: parts preparation | 76 |
| Passo 33 - Inserimento delle fascette | 77 |
| Passo 34 - Connecting the head cable | 77 |
| Passo 35 - Fissare i cavi | 78 |
| Passo 36 - Haribo time! | 78 |
| Passo 37 - INDX PTFE holders: parts preparation | 79 |
| Passo 38 - Installing the PTFE-holder-left | 79 |
| Passo 39 - Installing the PTFE-holder-right | 80 |
| Passo 40 - Side filament sensors: parts preparation | 80 |
| Passo 41 - Inserimento delle guaine | 81 |
| Passo 42 - Inserting the collets | 81 |
| Passo 43 - Installare i magneti | 82 |
| Passo 44 - Assembling the FS: parts preparation I | 82 |
| Passo 45 - Assembling the FS: parts preparation II | 83 |
| Passo 46 - Inserting the steel balls | 83 |
| Passo 47 - Attaching the magnets | 84 |
| Passo 48 - Assembling the FS-top left | 84 |
| Passo 49 - Assembling the FS-top right | 85 |
| Passo 50 - Covering the filament sensor - left | 85 |
| Passo 51 - Covering the filament sensor - right | 86 |
| Passo 52 - PTFE tubes - left side: parts preparation | 86 |
| Passo 53 - Preparing the filament sensor - left | 87 |
| Passo 54 - Mounting the filament sensor - left | 87 |
| Passo 55 - Connecting the PTFE tube - left | 88 |
| Passo 56 - PTFE measurement: parts preparation | 88 |
| Passo 57 - Attaching the PTFE tubes - left | 89 |
| Passo 58 - Measurement info | 89 |
| Passo 59 - Inserting the PTFE tubes (position 1,2) | 90 |
| Passo 60 - Inserting the PTFE tubes (position 3,4) | 90 |
| Passo 61 - PTFE tubes - right side: parts preparation | 91 |
| Passo 62 - Preparing the filament sensor - right | 91 |
| Passo 63 - Mounting the filament sensor - right | 92 |
| Passo 64 - Connecting the PTFE tube - right | 92 |
| Passo 65 - Attaching the PTFE tubes - left | 93 |
| Passo 66 - Inserting the PTFE tubes (position 5,6) | 93 |
| Passo 67 - Inserting the PTFE tubes (position 7,8) | 94 |

| | |
|---|-----------|
| Passo 68 - Connecting the filament sensor cable | 94 |
| Passo 69 - È l'ora delle Haribo! | 95 |
| Passo 70 - Fatto | 95 |
| 5. Spool holders & Tool dock assembly | 96 |
| Passo 1 - Attrezzi necessari per questo capitolo | 97 |
| Passo 2 - Side handle: parts preparation | 97 |
| Passo 3 - Installing the side handle | 98 |
| Passo 4 - Dock fan cable: parts preparation | 98 |
| Passo 5 - Dock fan head cable | 99 |
| Passo 6 - Securing the zip ties I. | 99 |
| Passo 7 - Securing the zip ties II. | 100 |
| Passo 8 - Attaching the dock fan cable | 100 |
| Passo 9 - Leading the dock fan cable I. | 101 |
| Passo 10 - Leading the dock fan cable II. | 101 |
| Passo 11 - Securing the dock fan cable | 102 |
| Passo 12 - Tightening the zip ties I. | 102 |
| Passo 13 - Tightening the zip ties II. | 103 |
| Passo 14 - Nozzle cleaner: parts preparation I. | 104 |
| Passo 15 - Nozzle cleaner: parts preparation II. | 104 |
| Passo 16 - Assemblaggio del Wiper-lock | 105 |
| Passo 17 - Securing the Wiper-lock | 105 |
| Passo 18 - Installare il Wiper-adjuster (Supporto Raschietto) | 106 |
| Passo 19 - Inserting the wiper blocks | 106 |
| Passo 20 - Installing the nozzle cleaner | 107 |
| Passo 21 - Electronics covers: parts preparation | 107 |
| Passo 22 - Securing the cables | 108 |
| Passo 23 - Wiring check | 108 |
| Passo 24 - Coprire la scatola di xBuddy | 109 |
| Passo 25 - Installare la copertura posteriore | 109 |
| Passo 26 - Bottom puck holders: parts preparation | 110 |
| Passo 27 - Assembling the bottom puck holders | 110 |
| Passo 28 - Removing the screws - right | 111 |
| Passo 29 - Mounting the bottom puck holders - right | 111 |
| Passo 30 - Securing the front Puck-holder bottom - right I. | 112 |
| Passo 31 - Securing the front Puck-holder bottom - right II. | 112 |
| Passo 32 - Securing the rear Puck-holder bottom - right I. | 113 |
| Passo 33 - Securing the rear Puck-holder bottom - right II. | 113 |
| Passo 34 - Removing the screws - left | 114 |
| Passo 35 - Mounting the bottom puck holders - left | 114 |
| Passo 36 - Securing the front Puck-holder bottom - left I. | 115 |
| Passo 37 - Securing the front Puck-holder bottom - left II. | 115 |
| Passo 38 - Securing the rear Puck-holder bottom - left I. | 116 |
| Passo 39 - Securing the rear Puck-holder bottom - left II. | 116 |
| Passo 40 - Tilting the printer | 117 |
| Passo 41 - Finishing the rear puck holder bottom - left I. | 118 |
| Passo 42 - Finishing the rear puck holder bottom - left II. | 118 |
| Passo 43 - Finishing the front puck holder bottom - left I. | 119 |
| Passo 44 - Finishing the front puck holder bottom - left II. | 119 |
| Passo 45 - Finishing the rear puck holder bottom - right I. | 120 |
| Passo 46 - Finishing the rear puck holder bottom - right II. | 120 |
| Passo 47 - Finishing the front puck holder bottom - right I. | 121 |
| Passo 48 - Finishing the front puck holder bottom - right II. | 121 |
| Passo 49 - Top puck holders: parts preparation | 122 |
| Passo 50 - Assembling the puck holder top | 122 |

| | |
|---|------------|
| Passo 51 - Removing the nylon rivets - right | 123 |
| Passo 52 - Mounting the front puck holder top - right | 123 |
| Passo 53 - Securing the front puck holder top - right | 124 |
| Passo 54 - Mounting the rear puck holder top - right | 124 |
| Passo 55 - Securing the rear puck holder top - right | 125 |
| Passo 56 - Removing the nylon rivets - left | 125 |
| Passo 57 - Mounting the front puck holder top - left | 126 |
| Passo 58 - Securing the front puck holder top - left | 126 |
| Passo 59 - Mounting the rear puck holder top - left | 127 |
| Passo 60 - Securing the rear puck holder top - left | 127 |
| Passo 61 - Dock fan: parts preparation | 128 |
| Passo 62 - Assembling the dock fan | 128 |
| Passo 63 - Attaching the FunFan board | 129 |
| Passo 64 - Attaching the dock fan | 129 |
| Passo 65 - Securing the dock fan | 130 |
| Passo 66 - È l'ora delle Haribo! | 130 |
| Passo 67 - Tool holder: parts preparation | 131 |
| Passo 68 - Assembling the tool holder | 131 |
| Passo 69 - Installing the tool holders | 132 |
| Passo 70 - Nozzle seal holder: parts preparation | 132 |
| Passo 71 - Assembling the nozzle seal | 133 |
| Passo 72 - Assembling the Nozzle-seal-holder | 133 |
| Passo 73 - Installing the nozzle parking plates | 134 |
| Passo 74 - Ventilation lever: parts preparation | 134 |
| Passo 75 - Assembling the ventilation lever | 135 |
| Passo 76 - Top cover: parts preparation I. | 135 |
| Passo 77 - Top cover: parts preparation II. | 136 |
| Passo 78 - Attaching the hinge covers | 136 |
| Passo 79 - Montaggio della griglia | 137 |
| Passo 80 - Attaching the left cover lock | 137 |
| Passo 81 - Attaching the right cover lock | 138 |
| Passo 82 - Top cover back: parts preparation | 138 |
| Passo 83 - Attaching the top cover back | 139 |
| Passo 84 - Attaching the hinge base - left | 139 |
| Passo 85 - Attaching the hinge base - right | 140 |
| Passo 86 - Attaching the top cover I. | 140 |
| Passo 87 - Attaching the top cover II. | 141 |
| Passo 88 - INDX Nozzle tool: parts preparation | 141 |
| Passo 89 - Attaching the tooldock | 142 |
| Passo 90 - Fissare il tooldock | 142 |
| Passo 91 - Montaggio del pannello LED | 143 |
| Passo 92 - Optional: Installing the Buddy3D Camera | 143 |
| Passo 93 - Connecting the INDX Nozzle tools (positions 1-4) | 144 |
| Passo 94 - Docking the tools (positions 1-4) | 144 |
| Passo 95 - Connecting the INDX Nozzle tools (positions 5-8) | 145 |
| Passo 96 - Docking the tools (positions 5-8) | 145 |
| Passo 97 - Checking the tubes | 146 |
| Passo 98 - Offset sensor cover: parts preparation | 146 |
| Passo 99 - Covering the offset sensor | 147 |
| Passo 100 - Pannello dello sportello: preparazione dei componenti | 147 |
| Passo 101 - Montare il pannello dello sportello | 148 |
| Passo 102 - Haribo time ! | 148 |
| Passo 103 - Questo è tutto | 149 |
| 6. Controllo finale | 150 |

| | |
|---|-----|
| Passo 1 - Montaggio del porta bobina: preparazione dei componenti | 151 |
| Passo 2 - Locking the spool holders | 151 |
| Passo 3 - Fissare la piastra di stampa | 152 |
| Passo 4 - Aggiornamento Firmware | 152 |
| Passo 5 - Accendere la stampante | 153 |
| Passo 6 - Impostazione della stampante: Introduzione | 153 |
| Passo 7 - Configurazione della stampante: Configurazione della rete | 154 |
| Passo 8 - Wizard: Intro | 154 |
| Passo 9 - Wizard: Door sensor calibration | 155 |
| Passo 10 - Wizard: Tensionamento della cinghia | 155 |
| Passo 11 - Wizard: Calibrazione del dock (parte 1) | 156 |
| Passo 12 - Wizard: Calibrazione del dock (parte 2) | 156 |
| Passo 13 - Wizard: Dock calibration (part 3) | 157 |
| Passo 14 - Wizard: Loadcell Test | 158 |
| Passo 15 - Wizard: Fan test | 158 |
| Passo 16 - Wizard: Tool offsets calibration | 159 |
| Passo 17 - Wizard: Calibrazione del pulitore degli ugelli | 159 |
| Passo 18 - Wizard: Nozzle cleaner calibration Z/X-axis | 160 |
| Passo 19 - Wizard: Calibrazione del Pulitore ugello sull'asse Y | 161 |
| Passo 20 - Wizard: Calibrazione dei sensori di filamento | 162 |
| Passo 21 - Wizard complete | 162 |
| Passo 22 - Haribo time! | 163 |
| Passo 23 - Nozioni base Prusa | 163 |
| Passo 24 - Give us feedback | 164 |
| Passo 25 - Join Printables! | 164 |

1. Introduction & preparation

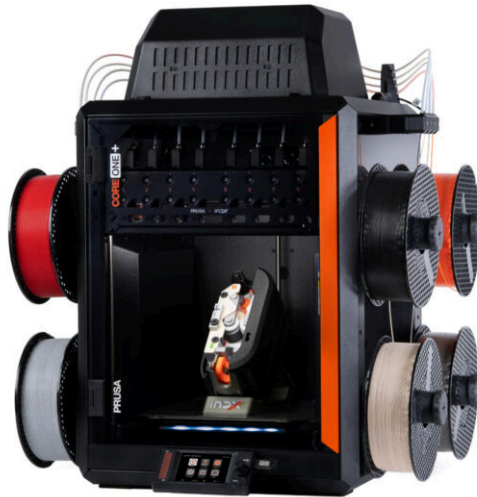

PASSO 1 Come navigare nel manuale

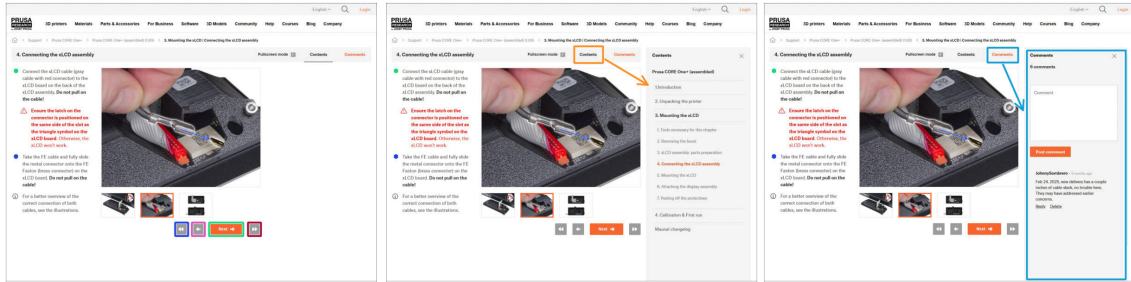

- Usa i pulsanti grafici di navigazione nell'angolo in basso a destra o i tasti freccia della tastiera:
- **Pulsante Play indietro / Tasto freccia su** - Vai al passo precedente.
- **Pulsante freccia sinistra / Tasto freccia sinistra** - Passa all'immagine precedente o alla fase precedente se si tratta della prima immagine della fase.
- **Pulsante successivo / Tasto freccia destra** - Passa all'immagine successiva o alla fase successiva se si tratta dell'ultima immagine della fase.
- **Pulsante Play Avanti / Tasto freccia giù** - Vai al passo successivo.
- Clicca su **Contenuti** per espandere l'elenco completo dei passi di questa guida. Questo ti permette di saltare a qualsiasi passo, indipendentemente dalla sequenza.
- Clicca su **Commenti** per aprire la discussione su un passo specifico e lasciare il tuo feedback.

PASSO 2 Visualizza immagini ad alta risoluzione

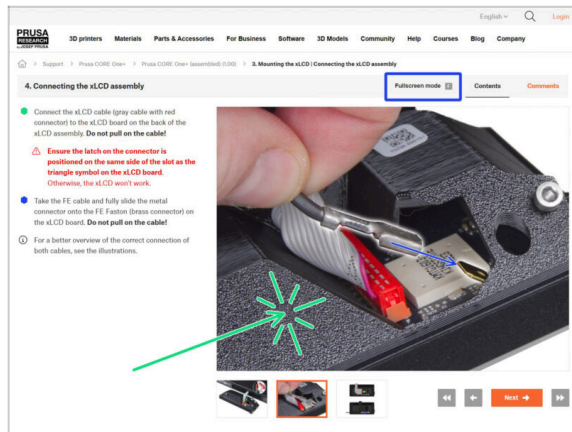

- Quando sfogli la guida su help.prusa3d.com, per maggiore chiarezza puoi vedere le immagini originali in alta definizione.
- Clicca sull'immagine per aprirla ad alta risoluzione e vederla nel dettaglio.
- Clicca sulla **modalità a schermo intero** o premi il tasto F per massimizzare lo spazio sullo schermo e concentrarti completamente sulle istruzioni.

PASSO 3 Before you begin



The **INDX Conversion kit is compatible with the Prusa CORE One and CORE One+**. This guide uses the CORE One+; some disassembly steps may vary between models.

- The required steps depend on your printer's current state:
 - **If your CORE One+ is brand new** and still unboxed, first follow the CORE One+ Unpacking & First run guide before installing the Bondtech INDX conversion.
 - **If you already use the CORE One+** and purchased only the INDX Conversion kit (Founders Edition) you can continue with this guide.

PASSO 4 Tutti gli utensili necessari sono inclusi

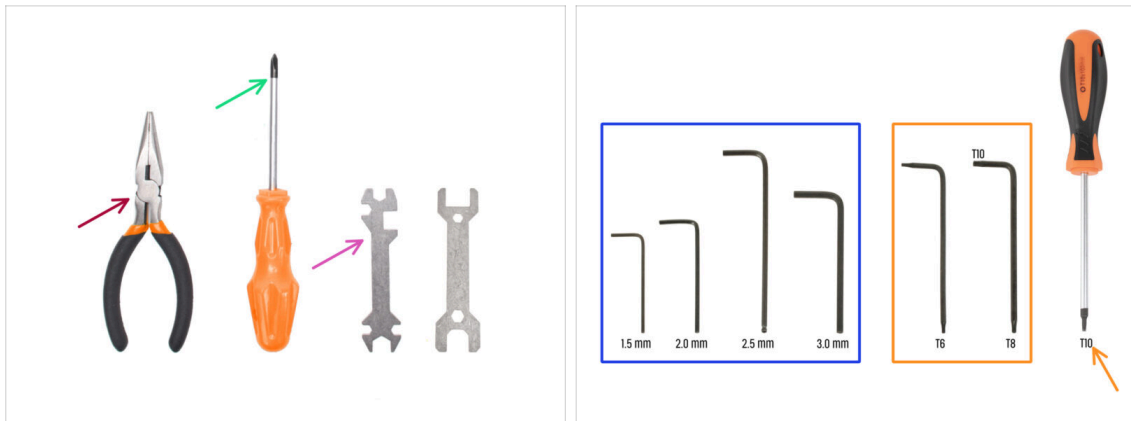

Tools required for this upgrade:



Use the tools originally included with your CORE One+ / CORE One printer.

- Needle-nose pliers (1x)
- Cacciavite a stella PH2 (1x)
- Chiave universale (1x)
- Set di chiavi a brugola
- Set di chiavi Torx

i The **T10 screwdriver is included only with kit versions** and may not be available with fully assembled printers.
It is not required, but may be more convenient in some steps.

PASSO 5 Labels guide

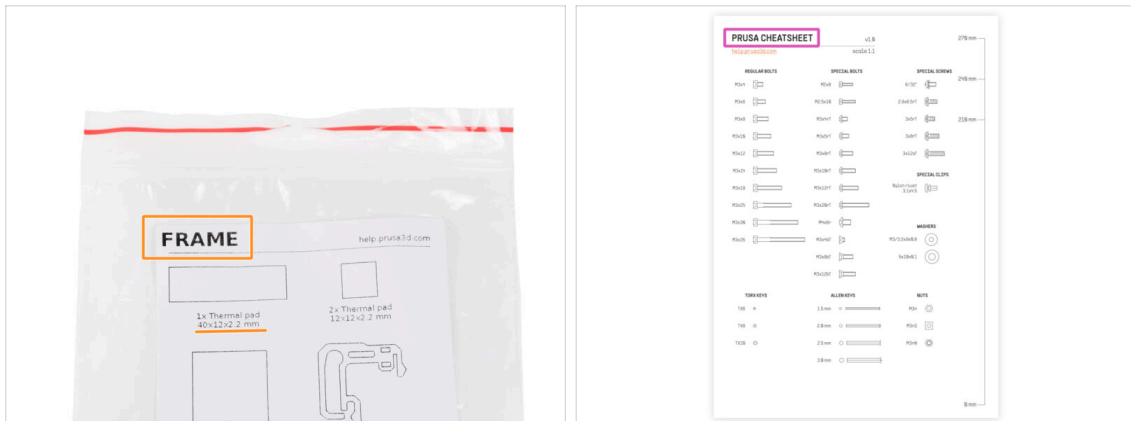

- Tutte le scatole e le buste contenenti le parti per l'assemblaggio sono etichettate.
- Le etichette includono l'elenco dei contenuti e il numero di pezzi.
- You can download a **Cheatsheet** with 1:1 fastener drawings from our site prusa.io/C1-INDX-cheatsheet. Print it at 100 %, don't rescale it, otherwise, it won't work.
- **i** Per i veterani PRUSA: I dispositivi di fissaggio sono divisi in sacchetti individuali a seconda del tipo. Non in pacchetti per i singoli capitoli, come avveniva con le stampanti precedenti.
- **📌** Le istruzioni indicheranno la confezione di ogni pezzo, tranne che per gli elementi di fissaggio, che si trovano sempre nella confezione Fasteners.

PASSO 6 Spare bag



- La viteria di ricambio è inclusa in ogni sacchetto di viteria. La quantità di ricambi è sempre inclusa nel numero totale indicato sul sacchetto.
- Allo stesso modo, alcune parti potrebbero avere un pezzo in più nella stessa busta.

PASSO 7 Parti stampate - versione



- ◆ La maggior parte dei componenti stampati in 3D sono segnate con la loro versione.
 - ◆ **Serie E, F e Gx** (ad es. E1) - Queste parti sono stampate da Prusa Research e vengono distribuite con il kit.
 - ◆ **Serie R, S e Tx** (ad es. R1) - Queste parti sono disponibili su [printables.com](https://www.printables.com). Sono identiche a quelle di fabbrica.
 - ◆ I numeri indicano piccole modifiche che di solito riguardano dettagli del design. Un'etichetta diversa nel manuale (ad esempio, una versione diversa mostrata nelle foto) non cambia il montaggio: tutte le versioni sono perfettamente compatibili.
- ⓘ if you have issues while assembling the printer with a specific printed part, find the label and share it with our support team.

PASSO 8 Siamo qui per te!

The screenshot shows the Prusa 3D printer manual website. The main content area displays step 4, "Connecting the xLCD assembly", with instructions and images. A comments section is visible, showing a user's question "Oh look at the detail!" and a response from "JohnyFanBros" dated Feb 24, 2025, mentioning a cable stack issue. A pink arrow points from the "Chat now" button to the "SUBMIT" button.

- Ti sei perso nelle istruzioni, ti manca una vite o hai una parte stampata rotta?
Faccelo sapere!
- Puoi contattarci attraverso i seguenti canali:
 - Utilizzando i commenti sotto ogni passo.
 - Utilizzando la nostra chat dal vivo 24 ore su 24, 7 giorni su 7, qui su help.prusa3d.com
 - Scrivendo una mail a info@prusa3d.com

PASSO 9 Pro tip: inserire i dadi

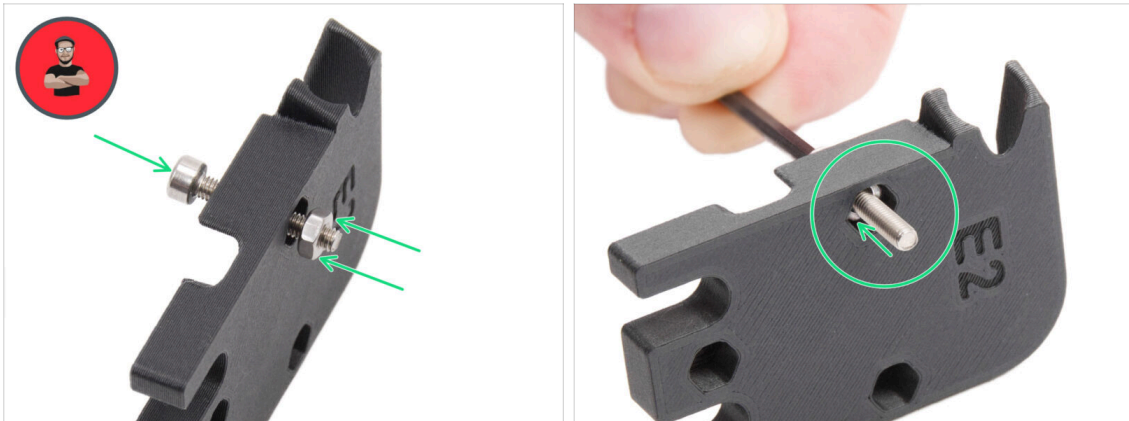

- Le parti stampate in 3D sono molto precise, tuttavia esiste una tolleranza, e lo stesso vale per la dimensione del dado.
- Per questo motivo può capitare che il dado non si inserisca facilmente o che cada. Vediamo come risolvere il problema:
 - **Il dado non entra:** usa una vite filettata per l'intera lunghezza (di solito M3x10, M3x18) e avvitala dal lato opposto dell'apertura. Stringendo la vite, il dado verrà tirato dentro. Rimuovi la vite alla fine dell'operazione.
 - **Il dado continua a cadere:** Usa un pezzo di nastro adesivo per fissare temporaneamente il dado in posizione, quando inserisci la vite potrai rimuoverlo. *Usare la colla è sconsigliato in quanto potrebbe raggiungere la filettatura e rendere impossibile stringere correttamente la vite.*
- Ogni volta che consigliamo di utilizzare la "tecnica del tiro della vite", ti verrà ricordato tramite l'avatar di Jo ;)
- ⓘ Le parti nelle immagini sono usate come esempio.

PASSO 10 Important: Electronics protection

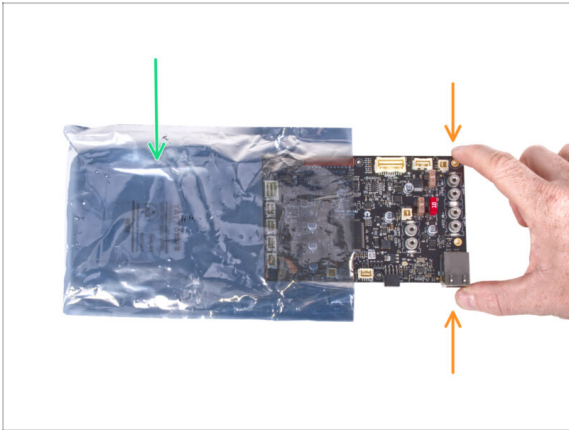

⚠ ATTENZIONE: Accertati di **proteggere l'elettronica dalle scariche elettrostatiche (ESD)**. Spacchetta sempre l'elettronica solo non appena ti serve!

● Di seguito, alcuni **consigli per evitare danni all'elettronica:**

- **Lascia l'elettronica dentro la busta ESD** fino a quando non ti viene chiesto di installarla.
- **Maneggiando la scheda, toccane sempre solo i lati.** Evita di toccare i componenti sulla superficie.
- **Prima di toccare l'elettronica,** serviti di una struttura conduttiva (metallica) nelle vicinanze per eliminare l'eventuale carica statica delle tue mani.
- Presta particolare attenzione **alle stanze con tappeti**, che spesso sono una fonte di energia elettrostatica.
- Anche i vestiti di lana o di alcuni tessuti sintetici possono accumulare facilmente elettricità statica. È più sicuro indossare abiti di cotone per l'assemblaggio.



PASSO 11 Datti una ricompensa



- Converting your CORE One+ to the INDX CORE One+ is a rewarding experience. After finishing each chapter, reward yourself. **There is a bag of Haribo bears in the box just for that!**
 - Do not eat all the bears before you start or at once! Not following instructions will have serious consequences. We are currently assembling the Prusa Haribo tactical squad for this matter.
 - After years of scientific research, we came up with a solution. **Throughout the guide, we will tell you exactly how many bears to consume.**
 - Mangiare una quantità non corretta rispetto a quella prescritta nel manuale potrebbe causare un improvviso aumento di energia. Consulta un professionista nel negozio di caramelle più vicino.
- ⚠ **Cut open** the bag of the Prusa Haribo carefully so the gummy bears don't spill onto the table. This step is very important!
- ⚠ **Nascondi le Haribo per ora!** Secondo la nostra esperienza, una busta di caramelle lasciata incustodita potrebbe sparire all'improvviso. Questo fenomeno è confermato da numerosi casi in tutto il mondo.

PASSO 12 Come completare l'assemblaggio correttamente

Step 25 Attaching the spacers









Insert two M3n nuts to the X-carriage-back.

⌚ Use the screw pulling technique.

- From the opposite side, insert the M3x10 screw into the X-carriage-back. The screw must protrude from the "front" side of the part.
- Attach the spacer 10 mm on the M3x10 screw and tighten the screw. **Note the cutout of the same shape as the spacer. It must fit perfectly and must not rotate.**

2 comments

 **To successfully finish the INDX conversion, please follow all these:**

-  **Always read all the instructions at the current step first;** it will help you to understand what you need to do. Do not cut or trim unless you are told to!!!
-  **Do not follow pictures only!** It is not enough; the written instructions are as brief as they could be. **Read them.**
-  Read the comments from the other users; they are great sources of ideas. We read them too and, based on your feedback, improved the manual and the entire assembly.
-  **Use reasonable force;** the printed parts are tough, but not unbreakable. If it doesn't fit, check your approach twice.
-  **Do not remove or discard any parts** unless instructed to do so.
-  **Most importantly: Enjoy the build, and have fun.**

PASSO 13 Prepare your desk

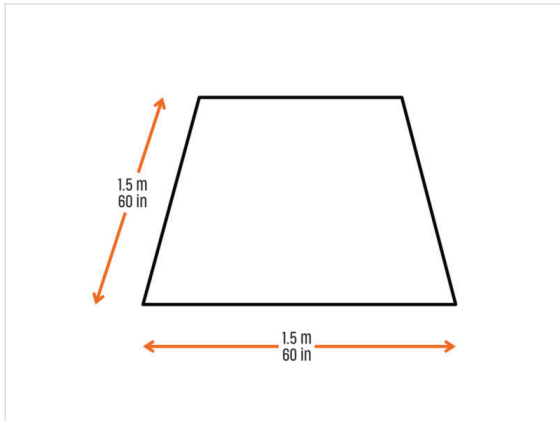

- **Libera l'area di lavoro.** Assicurati di avere abbastanza spazio. Un bel banco da lavoro libero e piatto ti permetterà di ottenere i risultati sperati.
- **Che ci sia luce!** Assicurati di essere in un ambiente ben illuminato. Una lampada o una torcia in più possono essere utili.
- Prepara qualcosa per contenere i sacchetti di plastica e i materiali di imballaggio rimossi, in modo da poterli riciclare in seguito. Assicurati che non vengano buttate parti importanti.
- Si consiglia uno spazio di lavoro minimo di 1,5 × 1,5 metri (60 × 60 pollici).

⚠ **We highly recommend placing a soft pad on your workbench. Some sheet metal parts have sharp edges that could scratch the surface.**

ℹ️ Puoi usare un pezzo di cartone come tappetino protettivo.

PASSO 14 Important information - Buddy3D camera

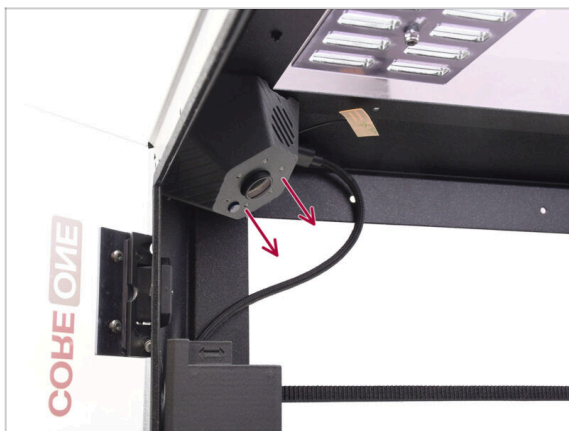

- If your printer is equipped with a Buddy3D camera, remove it before starting this procedure.
- The Buddy3D camera is magnetically attached. Simply remove it and disconnect the cable.
- There is no need to disconnect the camera cable.

📌 Place the camera in a safe location during the procedure. We recommend covering the lens with a protective cap.

PASSO 15 Firmware Info



Before you begin, make sure your printer is running **firmware version 6.5.3** or newer.

- On the printer display, go to **Info** -> **Version Info** -> **Firmware Version** to check your current version.
 - If your printer is already running firmware 6.5.3 or newer, continue to the next step.
- ⚠ **If your firmware is older, update it before starting the upgrade.**
 - Follow our dedicated firmware update guide for detailed instructions How to update firmware.
 - Once the firmware update is complete, return to this guide and continue.

PASSO 16 Spostare l'asse Z



Prima di iniziare, sposta il piano riscaldato in una posizione facilmente accessibile.



Durante questa fase, tieni lo sportello della stampante chiuso e non mettere le mani all'interno.

- Nel menu della stampante, vai su **Controllo** -> **Auto Home**.
- Dopo aver completato l'Auto Home, abbassa il piano riscaldato tramite **Controllo** -> **Sposta asse** -> **Sposta Z** finché non riesci a raggiungere le viti evidenziate e la parte inferiore del piano riscaldato (almeno 200 mm).
- ⓘ In questo modo entrambe le aree saranno facilmente accessibili durante la procedura, dato che dovranno essere gestite in seguito nel manuale.

PASSO 17 Unloading filament



- Assicurati che nella stampante non ci sia del filamento.9
- Scarica il filamento. Visita il menu **Filamento** e seleziona **Scarica filamento**.
- Scarica il filamento dalla stampante.
- Togli la bobina di filamento dalla stampante.

PASSO 18 Preparing the printer



- ⚠ Prima di iniziare, assicurati che la **stampante si sia raffreddata** a temperatura ambiente.
- Spegni la stampante utilizzando l'interruttore sul retro.
- Scollegare la stampante dall'alimentazione.
- Rimuovi la piastra d'acciaio.
- Place an empty cardboard box (e.g., a Prusament box) on the heatbed to protect it in case any parts fall.
- **Rimuovi la chiavetta USB** per evitare di danneggiarla mentre maneggi la stampante.
- OK, we are ready. Let's start! Go to chapter **2. Printer disassembly**.

2. Printer disassembly



PASSO 1 Attrezzi necessari per questo capitolo

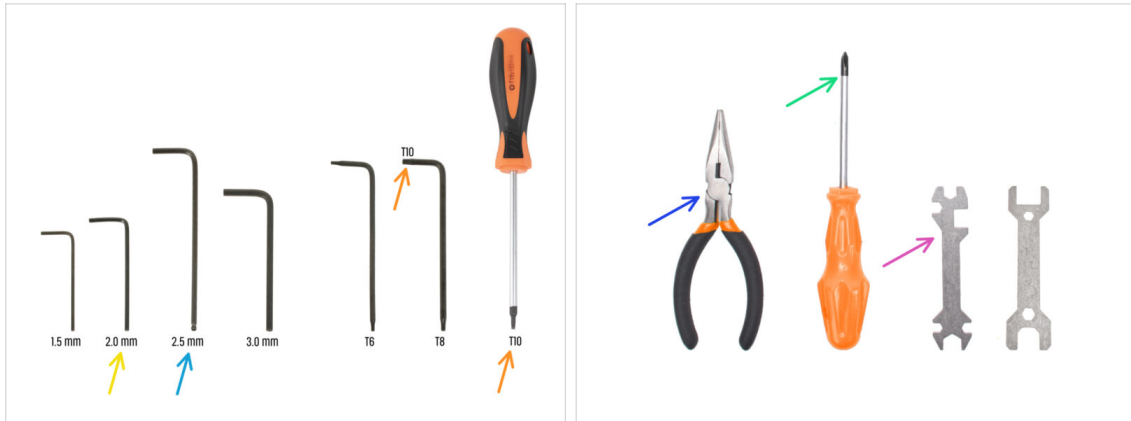

● **Per questo capitolo prepara:**

- Chiave a brugola da 2.0mm
- 2.5mm Allen key
- T10 key / screwdriver
- Needle-nose pliers or flush cutters for cutting zip ties
- Cacciavite a stella PH2
- Chiave universale

PASSO 2 Important information - removed parts

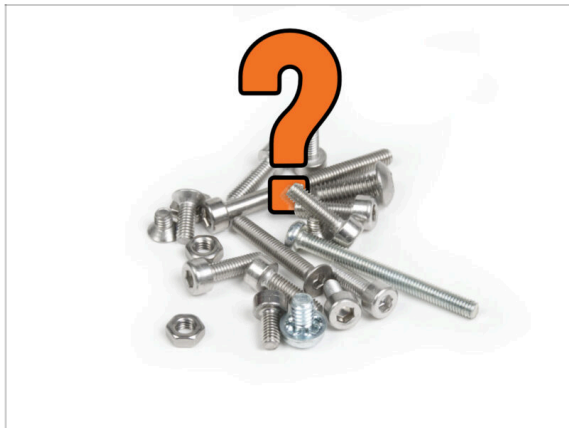

⚠ **Do not discard any printer parts during this procedure.**

● Some of the removed printer parts will be reused later and are listed at the end of this chapter.

● From the fasteners, **we recommend keeping all removed screws.**

ⓘ Some of the removed screws will be reused during the conversion. We recommend labeling these as you set them aside.

PASSO 3 Removing the top nylon rivets



- ◆ There are four nylon rivets on the top panel that secure it. Remove these nylon rivets as follows:
 - ◆ Using needle-nose pliers, carefully grasp the rivet head with the tip of the pliers and pull it out.
 - ⚠ Be careful not to damage the top panel.
 - ◆ If the lower part of a rivet remains in the panel, grasp it with pliers and remove it as well.

PASSO 4 Rimuovere il pannello superiore



- ◆ Remove the top panel from the printer.
- ⓘ You will not need the top panel for this upgrade.

PASSO 5 Removing the top profile

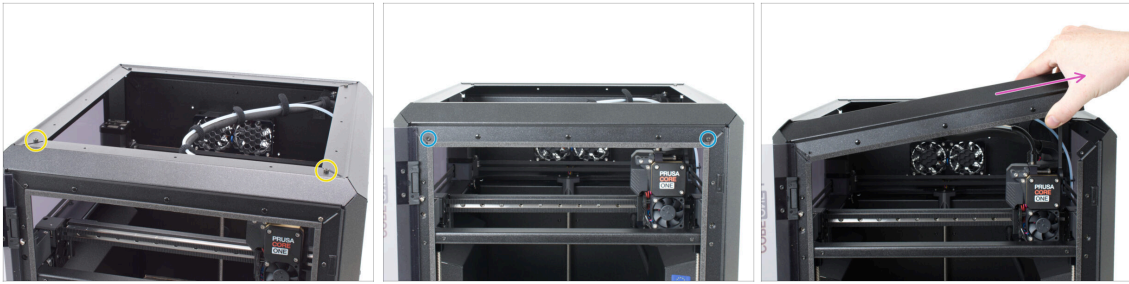

- Using the 2.5mm Allen key, remove the two M3x4 screws from the top front panel.
- From the front, use a T10 key to remove the two M3x4rT screws.
- Carefully remove the top profile from the printer.

PASSO 6 Removing the door

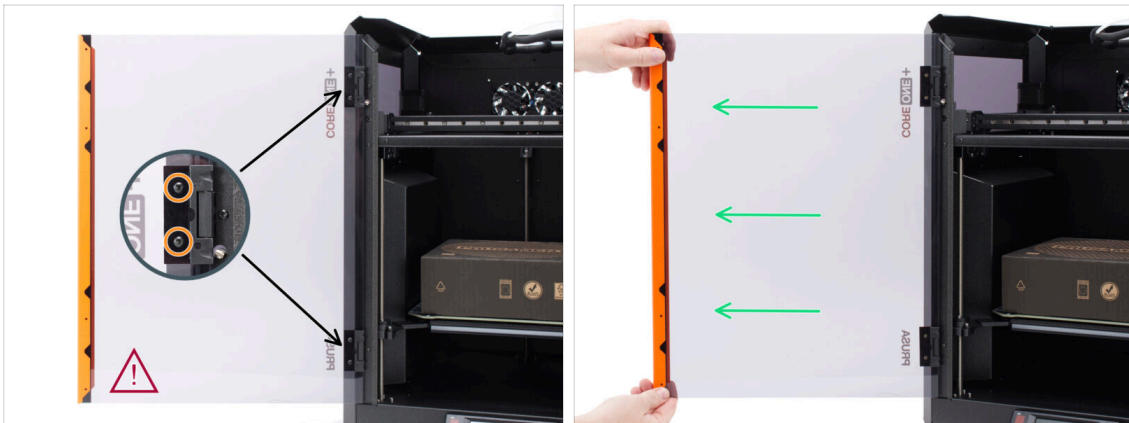

- ⓘ We highly recommend that you remove the door. This will make moving and turning the printer a lot easier and safer during the INDX conversion.
- Loosen and remove two M3x5rT screws securing the door panel in both hinges.
- ⚠ È essenziale **tenere saldamente il pannello dello sportello** mentre si allentano le viti per evitare che cada.
- 📌 Inizia a svitare le viti partendo da quelle più in basso.
- Fai scivolare con attenzione il pannello dello sportello fuori dalle cerniere.
- Place the door panel and the four screws in a **clean and safe area** to avoid any damage.
- 📌 Ensure that the shaft that is inside the hinge does not fall out. If the shaft falls out, insert it back in, or set it aside along with the hinge part. We will mount these back on at the end of the assembly.

PASSO 7 Accesso all'elettronica

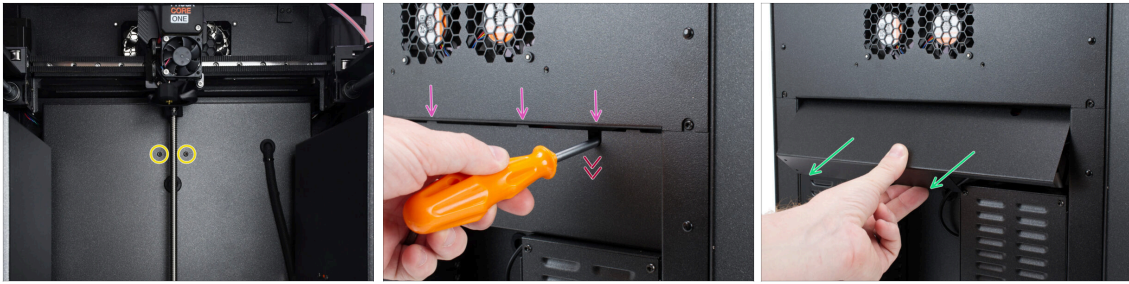

- All'interno della stampante, rimuovi le due viti M3x4rT che fissano la copertura posteriore.
- cSul retro della stampante, fai scorrere il coperchio centrale verso il basso.
🔑 Se è difficile da spostare, fai leva con un cacciavite attraverso l'apertura.
- Assicurati che i quattro ganci sulla parte superiore del coperchio si siano sganciati dal telaio metallico.
- Remove the cover from the printer.

PASSO 8 Come accedere alla Buddy Board



- Unscrew all six M3x4rT screws securing the electronics sheet (xBuddy box cover).
- Slide the xBuddy box cover out of the electronics box and remove it from the printer.

PASSO 9 Unplugging the cable I.

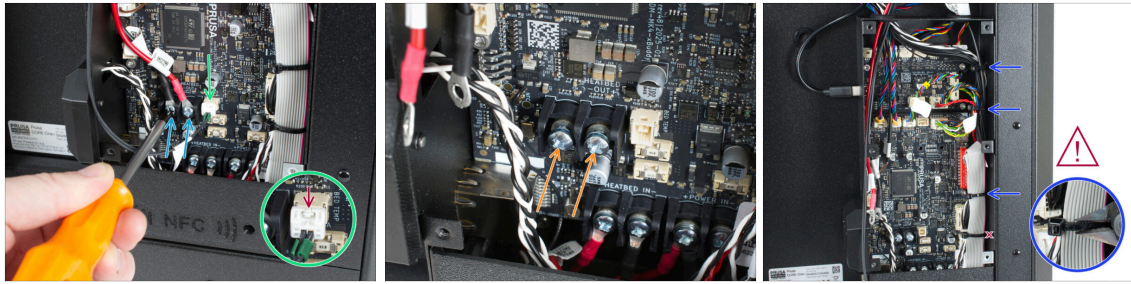

- ◆ Using a PH2 screwdriver, unscrew the two 6 32 screws and disconnect the heatbed power cables from the xBuddy.-32 screws and disconnect the heatbed power cables from the xBuddy.
- ◆ Pro tip: After disconnecting the cables, loosely thread both screws back in by at least three turns so they are not lost.
- ◆ Disconnect the heatbed thermistor cable from the xBuddy board.
- ⚠ Il connettore del cavo è dotato di un fermo di sicurezza. È necessario **premere il fermo prima di scollegare il cavo.**
- ◆ Carefully cut the zip ties along the right side of the xBuddy box. Do not cut the lower cable tie.
- ⚠ **Avoid cutting any cables.**
- ⓘ Cable ties can be cut using flush cutters, if available.

PASSO 10 Unplugging the cables II.

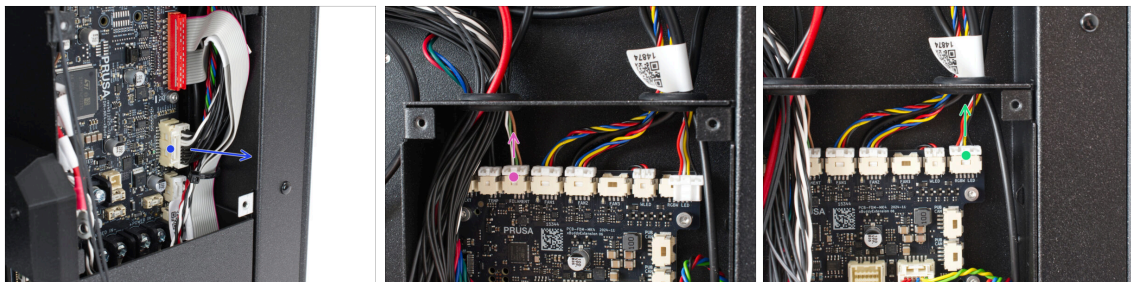

- ⚠ Il connettore del cavo è dotato di un fermo di sicurezza. È necessario **premere il fermo prima di scollegare il cavo.**
- ◆ Disconnect the Nextruder main cable from the xBuddy board.
- ◆ Disconnect the side filament sensor from the xBuddy extension board.
- ◆ Disconnect the RGB LED cable from the xBuddy extension board.

PASSO 11 Removing the cables

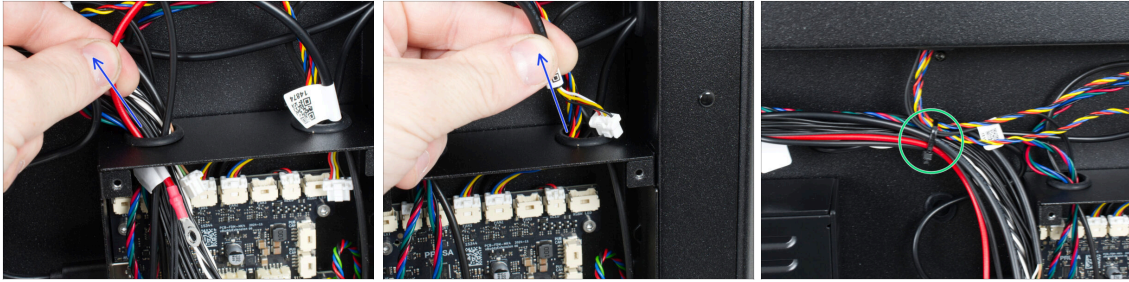

- ◆ Route the disconnected cables out of the xBuddy box through the corresponding openings at the top.
- ⚠ **Do not pull on the cables if you feel any resistance.**
- ⓘ Il cavo principale del Nextruder può passare sia dall'apertura destra che da quella sinistra, a seconda di come è stata assemblata la stampante.
- ◆ Be careful not to remove the grommets - but don't worry, they can be easily reinserted.
- ◆ Cut the zip ties securing the cable harness.
- ⚠ **Avoid cutting the cables.**

PASSO 12 Pushing the cables in



- ◆ Slide the upper grommet slightly out of the opening to prevent it from falling into the printer while routing the cables.
- ◆ Route the Nextruder main cable through the upper oval opening completely into the printer.
- ◆ Reinsert the grommet into the oval opening.
- ◆ Route the side filament sensor cable through the lower oval opening into the printer.

PASSO 13 Guiding the heatbed cables in

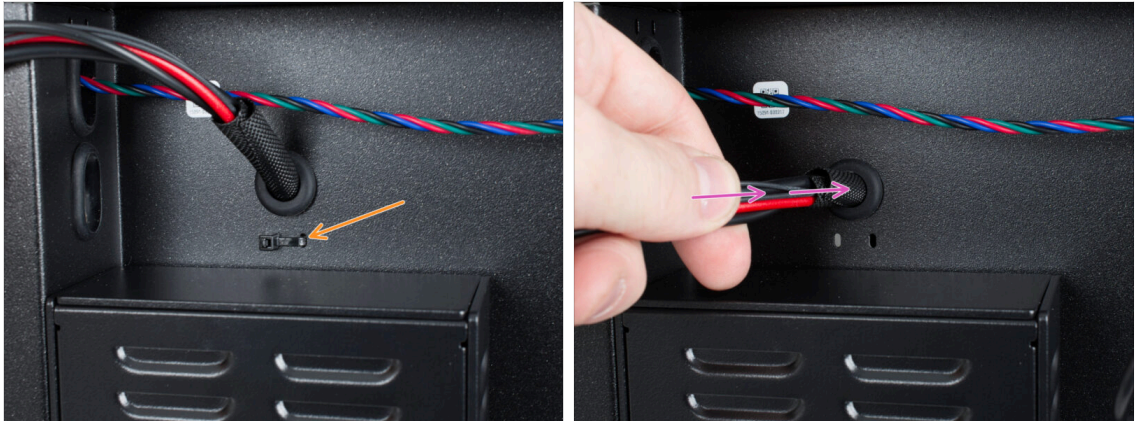

- ✦ Cut and remove the zip tie securing the heatbed cable bundle.
- ✦ Guide the heatbed cable bungle into the printer.
- Leave all loosened cables freely inside the printer. You will return to them later.

PASSO 14 Sganciare il cavo principale

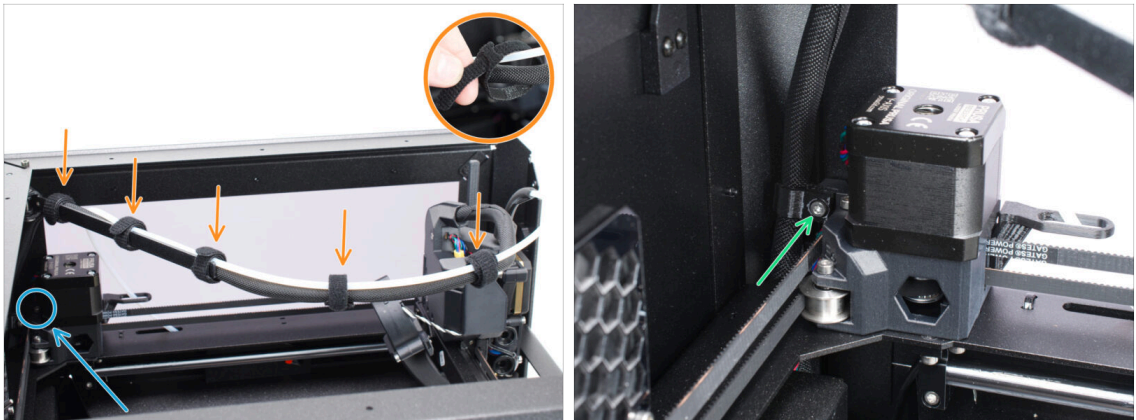

- Turn the printer so that its left side faces you (the side without the spool holder).
- ✦ Allenta i cinque fermacavi.
- Focus on the area behind the Y-axis motor.
- Using a 2.5 mm Allen key, loosen the M3 screw securing the cable clip.
- No need to remove the screws from the part. Let the Nextruder main cable hang freely together with the cable clip.

PASSO 15 Removing the LoveBoard cover



- Passiamo al lato sinistro del Nextruder.
- Utilizzando la chiave a brugola da 2,5 mm, rimuovi la vite M3x10 che tiene il coperchio laterale.
- Remove the cover.
- Unlock the Idler-swivel.
- Open the idler assembly fully.

PASSO 16 Disconnecting the Nextruder cables - left

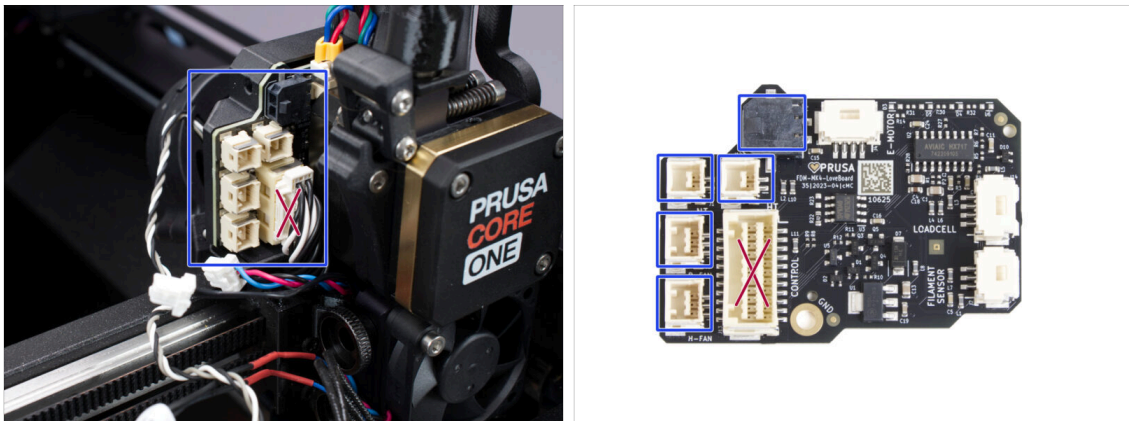

- ⚠ Ogni connettore è dotato di un fermo di sicurezza. **È necessario premere il fermo prima di scollegarlo.** In caso contrario, il connettore potrebbe danneggiarsi.
- Disconnect all cables on the left side of the LoveBoard.
- Do not disconnect the Nextruder main cable connector.

PASSO 17 Disconnecting the Nextruder cables - top

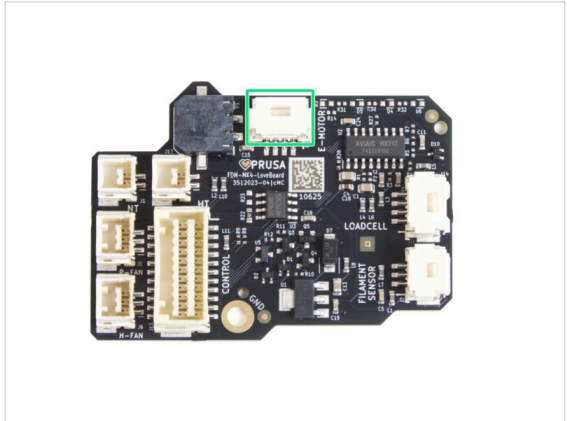
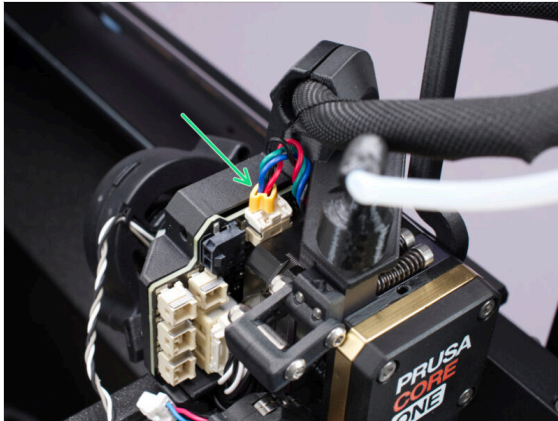

⚠ Each connector has a safety latch. It is necessary to **press the latch before disconnecting**. Otherwise, the connector may get damaged.

- 🟢 Disconnect the extruder motor cable.

PASSO 18 Disconnecting the Nextruder cables - right

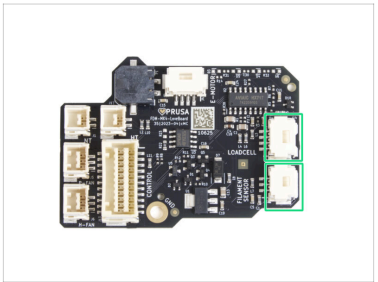
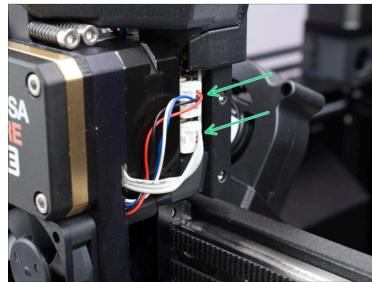
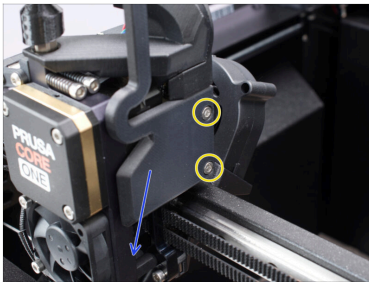

- 🟡 Using the Allen key, remove two M3x6 screws securing the right cover on the Nextruder.

- 🟠 Remove the cover.

⚠ Each connector has a safety latch. It is necessary to **press the latch before disconnecting**. Otherwise, the connector may get damaged.

- 🟢 Disconnect both cables from the right side of the LoveBoard.

PASSO 19 Scollegare il tubo in PTFE



- ◆ Slide the bowden-bend over the fitting in the Nextruder.
- ◆ Press the black collet in the fitting down, preferably using two fingers.
- ◆ Pull the PTFE tube out of the fitting.
- ◆ Remove the bowden-bend from the PTFE tube.

PASSO 20 Removing the Nextruder fitting

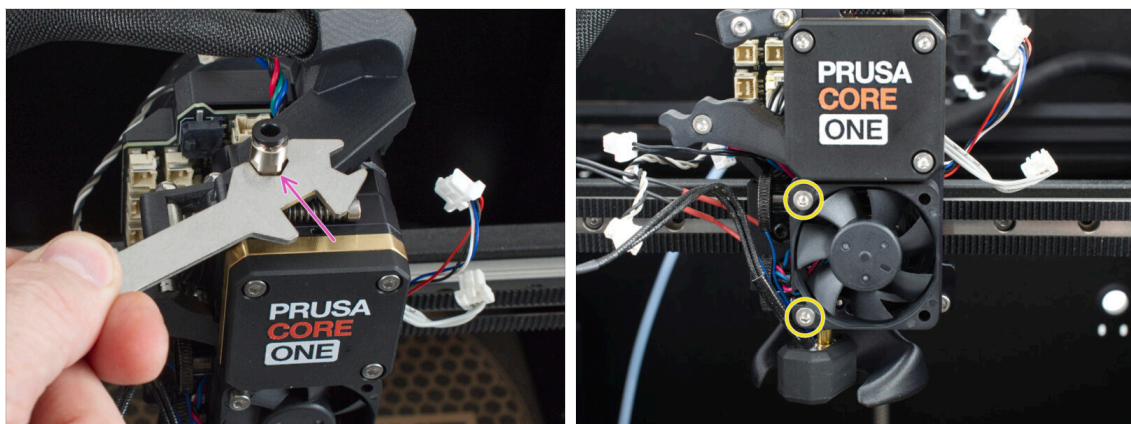

- ◆ Using the 8mm cutout on the Universal wrench, remove the M5-4 fitting.
- ◆ Using the Allen key, remove two M3x18 screws securing the heatsink fan.
- 📌 After being released, the heatsink fan will likely hang on the cable. Leave it as it is for now.

PASSO 21 Removing the Nextruder

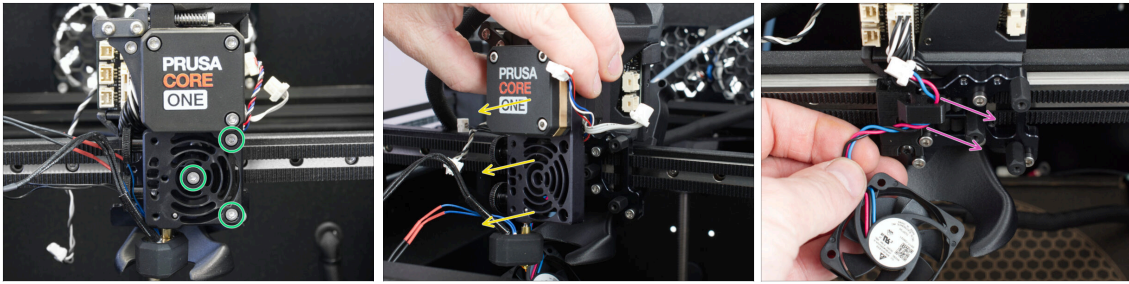

- ◆ Remove three M3x10 screws securing the Nextruder assembly to the X-axis.
 - ⚠ **CAUTION:** While loosening the last screw, hold the Nextruder to prevent it from falling and damaging the printer.
- ◆ Remove the Nextruder assembly from the printer.
- ◆ Unhook the heatsink fan cable from the cable hook and remove the fan from the printer.

PASSO 22 Rimuovere la ventola di stampa

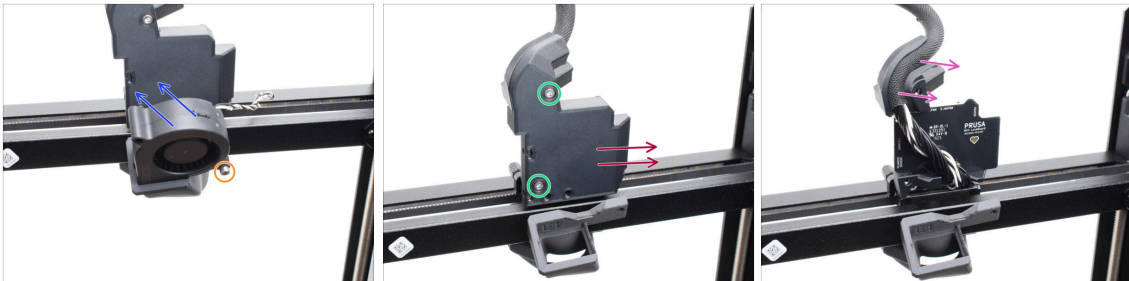

- ◆ Focus on the rear X-axis assembly.
- ◆ On the back of the print head, remove the M3x25 screw holding the print fan.
- ◆ Rimuovi la ventola di stampa sollevandola.
 - 📌 Set the print fan. It will be needed later for the new toolhead.
- ◆ Remove the two M3x10 screws holding the cover on the back of the print head.
- ◆ Remove the cover.
- ◆ Dislodge the extruder main cable from the dedicated groove.

PASSO 23 Rimuovere la LoveBoard



- ◆ Release and remove the M3x8rT screw securing the LoveBoard.
- ◆ Remove the LoveBoard with the Nextruder main cable completely from the printer.
- ◆ Loosen two M3x10 screws in the Loveboard-holder.
- ◆ Remove the Loveboard-holder from the printer.

PASSO 24 Removing the fan shroud

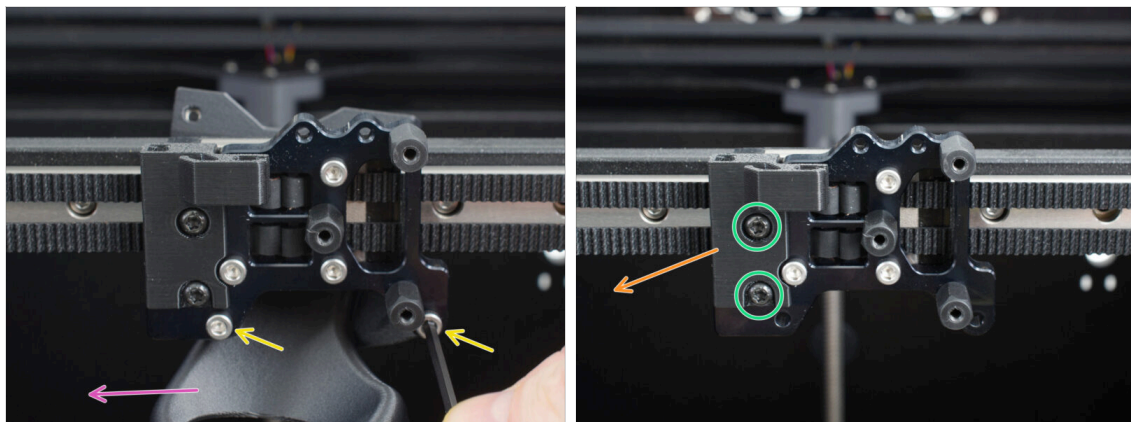

- ◆ Release and remove two M3x10 screws securing the Fan-shroud to the Nextruder holder.
- ◆ Remove the Fan-shroud from the printer.
- ◆ Using the T10 key, remove two M3x4rT screws mounting the Cable-clip.
- ◆ Remove the Cable-clip from the printer.

PASSO 25 Removing the side handle

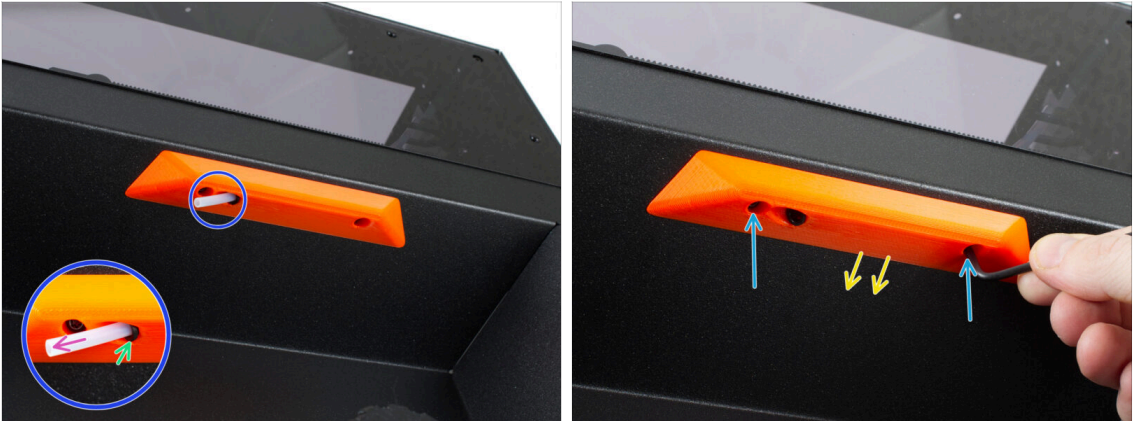

- Take a close look at the input PTFE tube in the handle on the right side panel.
- Push in the collete in the handle.
- Tira fuori il tubo in PTFE.
- Using the T10 screwdriver release two M3x8rT screws securing the handle and the filament sensor.
- Remove the handle from the printer.

PASSO 26 Removing the side filament sensor



- Shift your focus back inside the printer.
- Carefully cut and remove the zip tie near the PTFE tube.
 - This releases the side filament sensor cable from the underside of the CoreXY frame.
- Grasp the released side filament sensor on the inner side of the right side panel and remove it from the printer.

PASSO 27 Rimozione del porta bobina



✦ Using the T10 screwdriver, remove the four M3x8rT screws inside the printer securing the spoolholder.

⚠ Be careful **not to scratch the heated bed.**

✦ **While loosening the last screw, hold the spool holder in your hand and remove it from the printer.**

⚠ **Place the protective cardboard box back onto the heated bed.**

PASSO 28 Riepilogo parti I.



⚠ **Keep the following parts for the next steps.**

ⓘ Any parts not listed can be set aside.

- ✦ From the fasteners, we recommend **keeping all removed screws.**
- ✦ Sheet metal back cover (1x)
- ✦ xBuddy box cover (1x)
- ✦ Ventola di stampa (1x)
- ✦ Piastra di stampa (1x)
- ✦ Cable tie (2x)

PASSO 29 Parts recap II.



- ◆ Door panel assembly (1x)

PASSO 30 È l'ora delle Haribo!



- ⚠ Check the number in the circle carefully. It shows exactly how many gummy bears to eat in this step. **Do not eat more.**

- ◆ Mangia sei orsetti gommosi.

PASSO 31 Final step



- ◆ The printer is now ready for the INDX upgrade.
- ◆ Proceed to the next chapter: **3. Upgrading the printer.**

3. Aggiornamento dell'asse Z



PASSO 1 Attrezzi necessari per questo capitolo

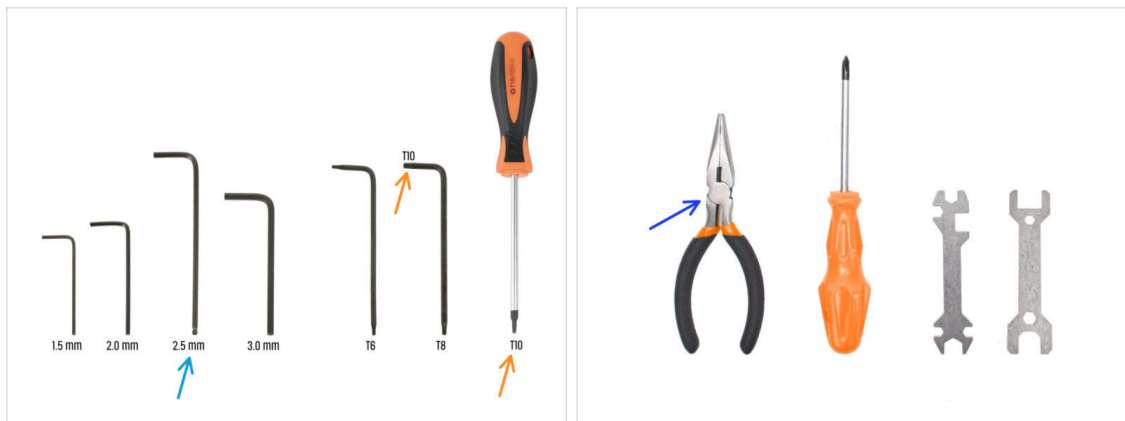

● **Per questo capitolo prepara:**

- Chiave a brugola da 2.5mm
- T10 key / screwdriver
- Needle-nose pliers or flush cutters for cutting zip ties

PASSO 2 Optional: Installing the Buddy3D Camera USB-C cable



① This step applies only if you **purchased the Buddy3D Camera** and plan to install it.

● Now is the right time to install the USB-C cable included with the Buddy3D Camera.

● To install the cable, follow the dedicated **Buddy3D Camera for CORE One Installation** guide.



Do not connect or mount the camera itself at this stage. This will be done at the end of the assembly.

PASSO 3 Rimozione del coperchio del cavo del piano riscaldato



- ◆ Temporarily remove the protective cardboard box from the heatbed.
- ◆ Focus on the heatbed cable area at the rear left.
- ◆ Unscrew two M3x10 screws securing the CORE-One-bed-cable-cover-top.
- ◆ Rimuovi la copertura CORE-One-bed-cable-cover-top.
- ⓘ You will no longer need the CORE-One-bed-cable-cover-top. We recommend removing it to avoid confusion with the new part.

PASSO 4 Releasing the heatbed

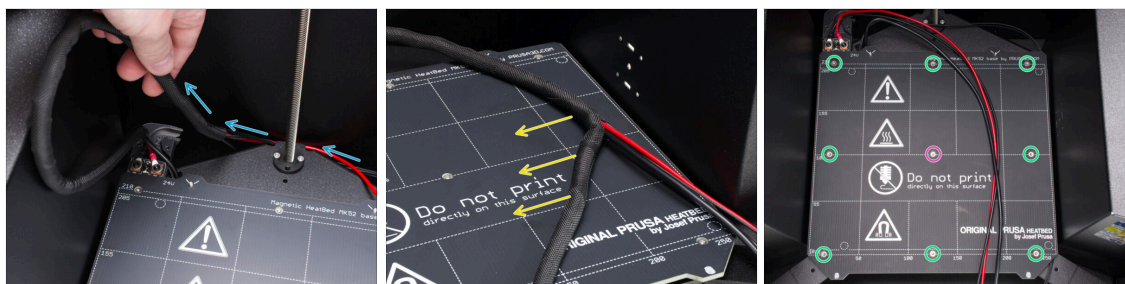

- ◆ Pull the heatbed cable bundle out from underneath the heatbed.
- ⚠ Be careful **not to snag the cables**. If you feel resistance, **stop pulling immediately**.
- ◆ Remove the textile sleeve from the entire length of the cable bundle.
- ⓘ Set the sleeve aside, you will need this part again later.
- ◆ Release and remove eight M3x4bT screws securing the heatbed.
- ◆ Release and remove the M3x12bT screw in the middle.

PASSO 5 Rimuovere il piano riscaldato

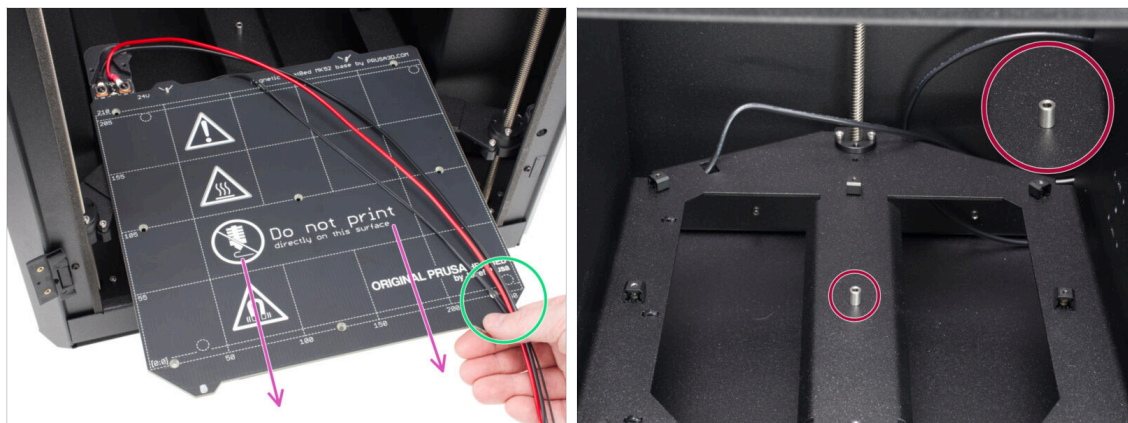

- Carefully remove the heated bed out of the printer.
 - Remove it together with the cables **leading from the heated bed**.
 - **Set the heated bed aside in a safe place**, it will be needed again later.
- ⚠ After removing the heated bed, a **spacer remains loose on the Z-carriage**. **Keep it in a safe place for later use**.

PASSO 6 Removing the bed spacer



- Loosen two M3x18 screw securing the trapezoidal nut and the CORE-One-bed-spacer-rear (on the underside).
 - While loosening the screws, hold the CORE-One-bed-spacer-rear in place and remove it once they are loose.
- 📌 **Leave the screws in the trapezoidal nut.**
- ⓘ Discard the CORE-One-bed-spacer-rear to avoid confusion with the new part. You will no longer need this part.

PASSO 7 Spessori piano riscaldato: preparazione componenti



- Per i seguenti passi prepara:
- INDX-C1-bed-spacer-rear (1x) found in the Heatbed bag
- INDX-C1-bed-spacer-front (2x) found in the Heatbed bag
- M3xN nut (2x) found in the Fasteners 1/2 bag
- M3x18 screw (4x) found in the Fasteners 1/2 bag

PASSO 8 Assembling the INDX-bed-spacer-rear



- Insert two M3xN nuts into the Bed-spacer-rear and **push them in as far as possible**.
- Insert the nuts with the nylon insert (blue plastic ring) **facing up**.

PASSO 9 Montaggio del INDX-bed-spacer-rear

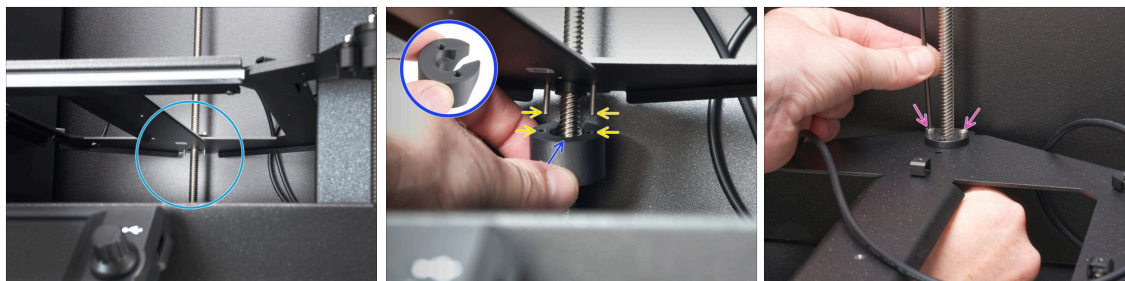

- Focus on the rear underside of the heatbed.
- Hold the Bed-spacer-rear **in the same orientation as shown** and fit it **around** the rear Z-axis threaded rod.
- Align the holes in the bed spacer with the M3x18 screws that you kept in the trapezoidal nut.
- Secure the part by tightening the two M3x18 screws.

PASSO 10 Inserting the spacer - left



- Focus on the front left Z-axis.
- Remove the two M3x10 screws securing the Z-carriage to the Z-axis.
⚠ Do not remove the screws from the trapezoidal nut.
- Gently lift the Z-carriage so that a gap of approximately 8 mm (0.3 inches) is created between it and the bed mount.
- Insert the Bed-spacer-front into the gap.
- Position the part so it fits around the bed mount, then align the holes.

PASSO 11 Securing the bed spacer - left



- i** Make sure the two M3nN nuts inserted from below do not fall out of the bed mount.
- Secure the spacer with two M3x18 screws.
 - Tighten the inner screw first.
 - Then tighten the outer screw.

PASSO 12 Inserting the spacer - right

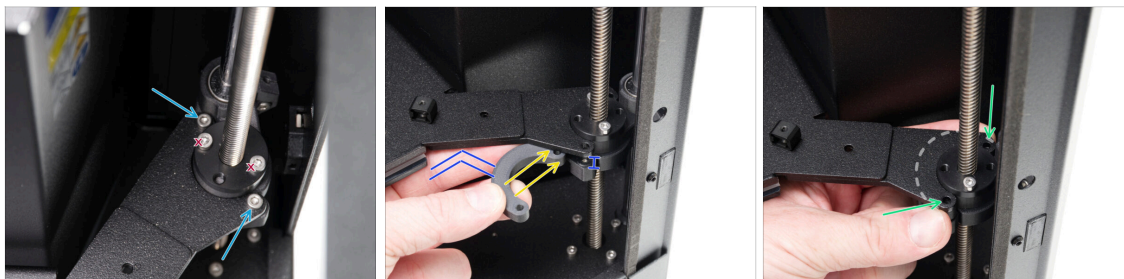

- Focus on the front right Z-axis.
- Remove the two M3x10 screws securing the Z-carriage to the Z-axis.
 - !** Do not remove the screws from the trapezoidal nut.
- Gently lift the Z-carriage so that a gap of approximately 8 mm (0.3 inches) is created between it and the bed mount.
- Insert the Bed-spacer-front into the gap.
- Position the part so it fits around the bed mount, then align the holes.

PASSO 13 Securing the bed spacer - right



- i** Note that there are two M3nN nuts inserted into the bed mount from below. Ensure that these do not fall out.
- Secure the spacer with two M3x18 screws.
 - Tighten the inner screw first.
 - Then tighten the outer screw.

PASSO 14 Offset sensor: parts preparation



- **For following steps, prepare:**
- INDX-C1-offset-sensor-holder (1x) *found in the Heatbed bag*
- INDX OffsetSensor (1x) *found in the Filament Sensors box*
- M3x8rT screw (1x)
- Vite M3x10 (1x) *rimossa in precedenza*
- Offset sensor cable (1x) *found in the Cables bag*
- Fascetta (4x)

PASSO 15 Mounting the INDX OffsetSensor



- i The printed parts shown may differ slightly from the parts included in your package.
- Mount the offset sensor onto the Offset-sensor-holder.
 - Align the screw holes with each other.
 - ! **Make sure the PRUSA logo is facing up.**
 - Ensure that the offset sensor is correctly positioned.
 - Secure the offset sensor in place with the M3x8rT screw.
- Do not overtighten the screw** to avoid damaging the electronics.
- Lead the offset sensor cable between the Z-carriage and the side panel of the printer.
 - Take the end of the cable **without a label**.

PASSO 16 Connecting the offset sensor cable

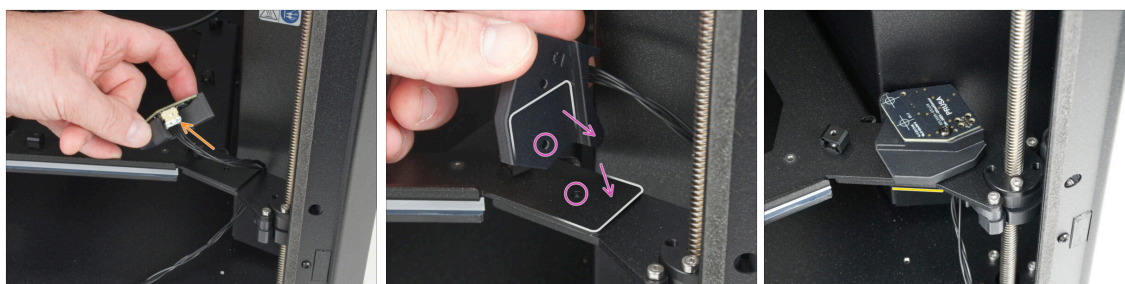

- Plug the offset sensor cable into the offset sensor board connector.
- On the underside of the Offset-sensor-holder, locate the pocket shaped for the Z-carriage.
 - Place the Offset-sensor-holder onto the Z-carriage so the shapes fit together and the screw holes align.
- Check the correct alignment. It must match the photo.

PASSO 17 Securing the offset sensor assembly

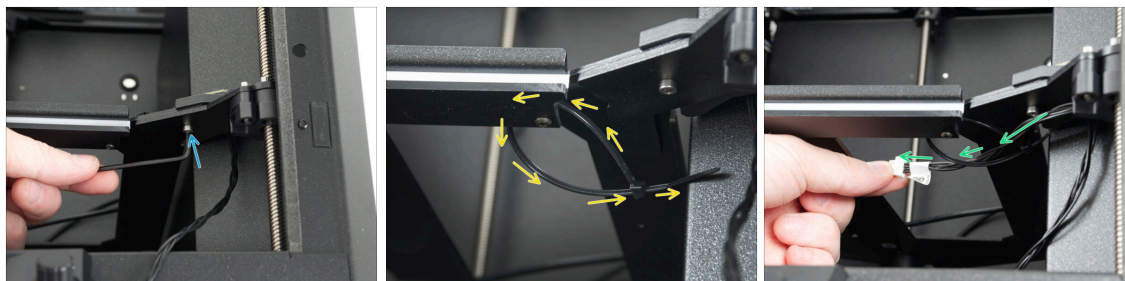

- ◆ Secure the offset sensor assembly to the Z-carriage from the underside using the M3x10 screw.
- ◆ Loop a zip tie around the screw in the LED panel assembly and secure it, **but do not tighten it yet.**
- ◆ Lead the offset sensor cable through the zip tie.

PASSO 18 Guiding the offset sensor cable

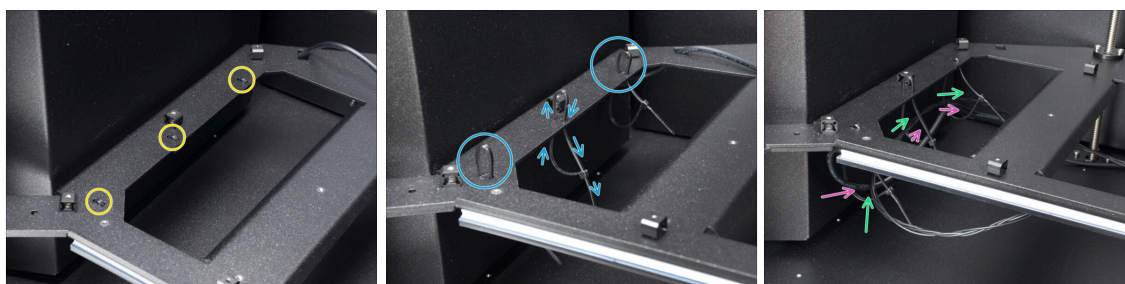

- ◆ On the left side of the Z-carriage, use side cutters to remove the three highlighted zip ties.
 - ⓘ Cutting the cable ties will release the RGB LED cable, which is secured by them.
- ◆ Thread three cable ties through the Z-carriage and connect their heads on the underside. Do not tighten them yet.
- ◆ Guide the offset sensor cable through the three zip ties.
- ◆ Guide the RGB LED cable through the three zip ties.

PASSO 19 Securing the offset sensor cable

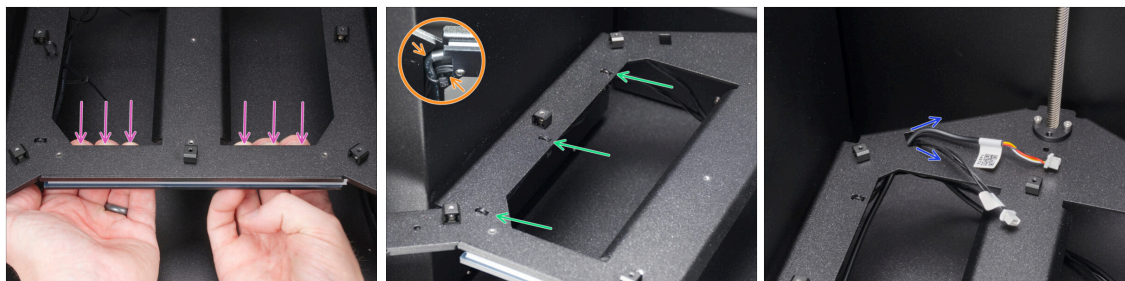

- ◆ Tuck the offset sensor cable in between the Z-carriage and the LED panel.
- ◆ Tighten all three cable ties and cut off the excess ends.
 - ◆ The cables before the first cable tie **must not be sharply bent**; leave a slight slack.
 - ◆ Make sure the cables are properly tensioned and **not sagging** along their entire length.
- ◆ Route the offset sensor and RGB LED cables upward through the rectangular cutout in the Z-carriage.

PASSO 20 Removing the Bed-cable-cover-bottom

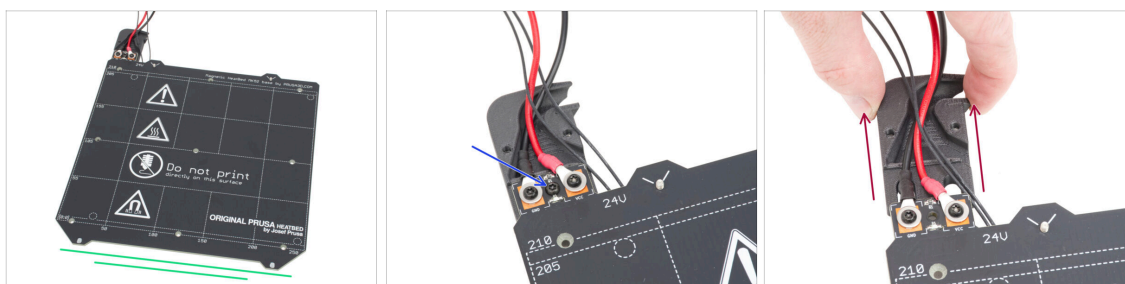

- ◆ Prepare the heatbed assembly.
- ◆ Using the Torx key, remove the M3x10rT screw that keeps the Bed-cable-cover-bottom attached.
- ◆ Remove the Bed-cable-cover-bottom.

PASSO 21 Heatbed cable covers: parts preparation

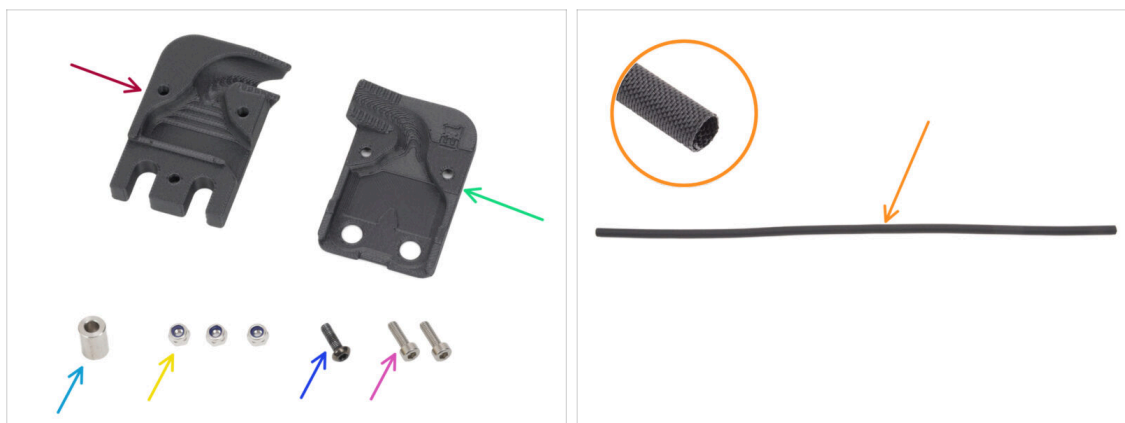

● Per i seguenti passi prepara:

- INDX-C1-bed-cable-cover-bottom (1x) *found in the Heatbed bag*
- INDX-C1-bed-cable-cover-top (1x) *found in the Heatbed bag*
- Heatbed spacer 6x3.1x8 mm (1x) *removed earlier*
- M3nN nut (3x) *found in the Fasteners 1/2 bag*
- M3x10rT (1x) *removed earlier*
- M3x10 screw (2x) *removed earlier*
- Textile sleeve 520 x 8 mm (1x) *remove earlier*

PASSO 22 Heatbed cable covers: parts preparation II

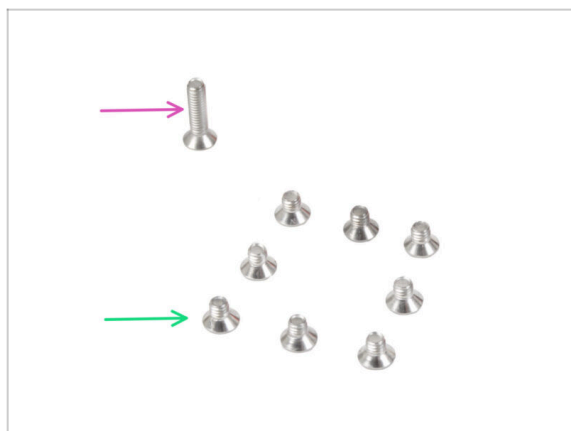

● Per i seguenti passaggi prepara:

- M3x12bT screw (1x) *removed earlier*
- M3x4bT screw (8x) *removed earlier*

PASSO 23 Assemblare la copertura Bed-cable-cover-bottom

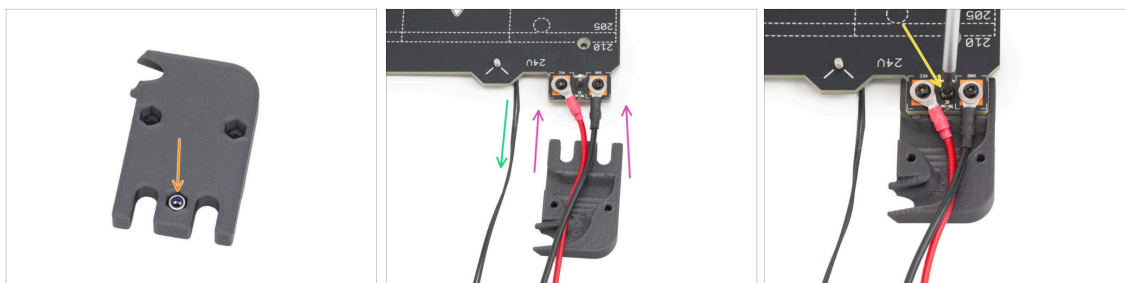

- 🟠 Insert the M3nN nut into the bottom hole in the Bed-cable-cover-bottom.
- 🟢 Route the heatbed thermistor cable outside the cover.
- 🟣 Insert the Bed-cable-cover-bottom under the heatbed power cables and slide the cover beneath the heatbed.
- 📄 **i** The M3nN nut may fall out during installation. You can hold it in place from the bottom with your finger.
- 🟡 Secure the Bed-cable-cover-bottom in place with the previously removed M3x10rT screw.

PASSO 24 Inserimento del piano riscaldato

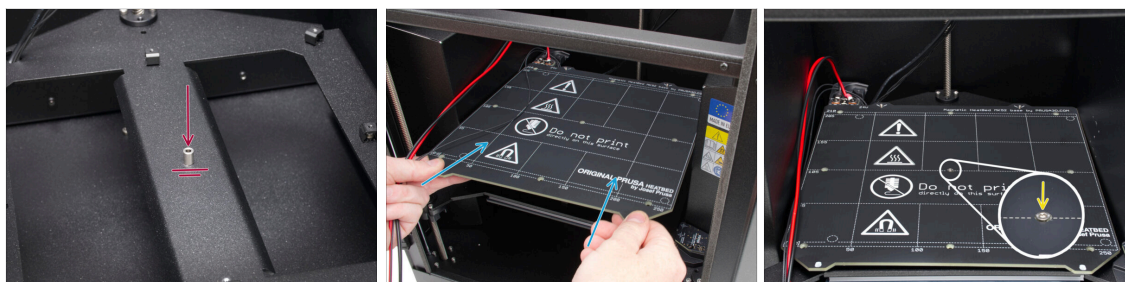

- 🟠 Place the heatbed spacer directly over the threaded hole in the center of the Z-carriage.
- 🟢 Carefully insert the heatbed assembly back into the printer.
 - 🟡 Ensure that the spacer in the middle stays in place.
- 🟡 Secure the heatbed in place with the M3x12bT screw that you set aside when initially removing the heatbed. **Do not fully tighten the screw yet.**

PASSO 25 Securing the heatbed

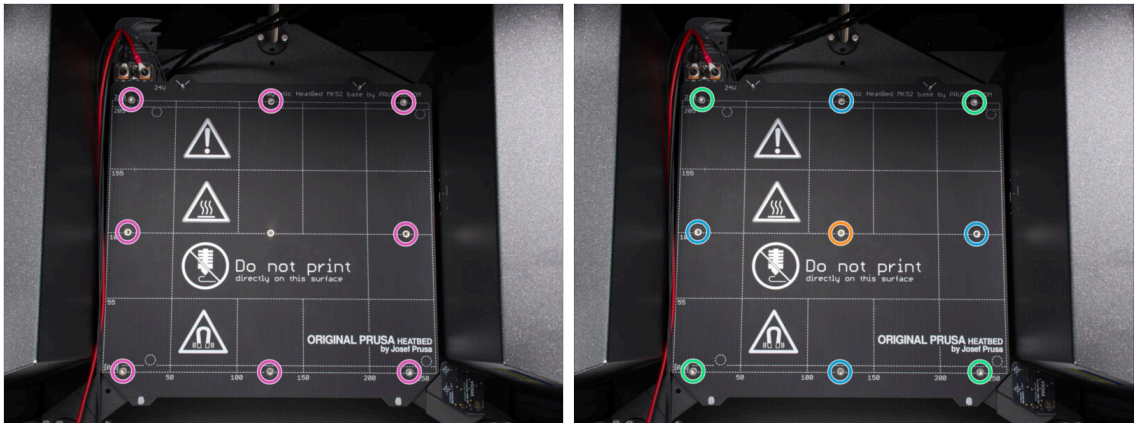

✿ Insert the M3x4B screws into the remaining holes in the heatbed. Do not fully tighten the screws yet.

⚠ **IMPORTANT:** The heatbed must be tightened in a specific order. Repeat the sequence multiple times, ensuring the final tightening after at least two rounds.

⬛ **After all screws are in place, tighten them in the following sequence:**

- ✿ Vite centrale
- ⬢ Prime quattro viti (bordi)
- ✿ Ultime quattro viti (angoli)

📌 Stringi le viti delicatamente, ma con decisione.

PASSO 26 Avvolgere i cavi del piano riscaldato

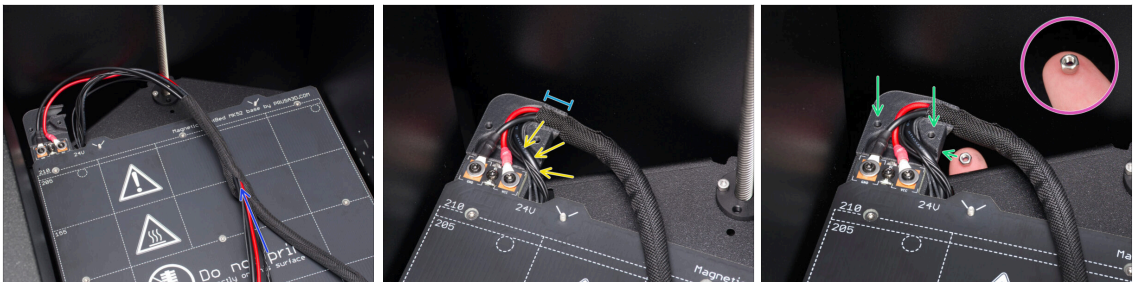

⬢ Wrap the textile sleeve around the heatbed, RGB LED, and offset sensor cables.

✿ Route the RGB LED and offset sensor cables into the Heatbed-cable-cover-bottom through the side channel.

⬢ Slide the textile sleeve at least 1 cm (0.39 in) into the cable channel.

✿ Place the M3nN nut on your finger with the nylon insert (blue plastic ring) facing down.

✿ **From below**, align it with the screw holes shown in the picture.

⬛ Then **press the nut into the Bed-cable-cover-bottom** from underneath until it is fully seated.

PASSO 27 Coprire i cavi del piano riscaldato

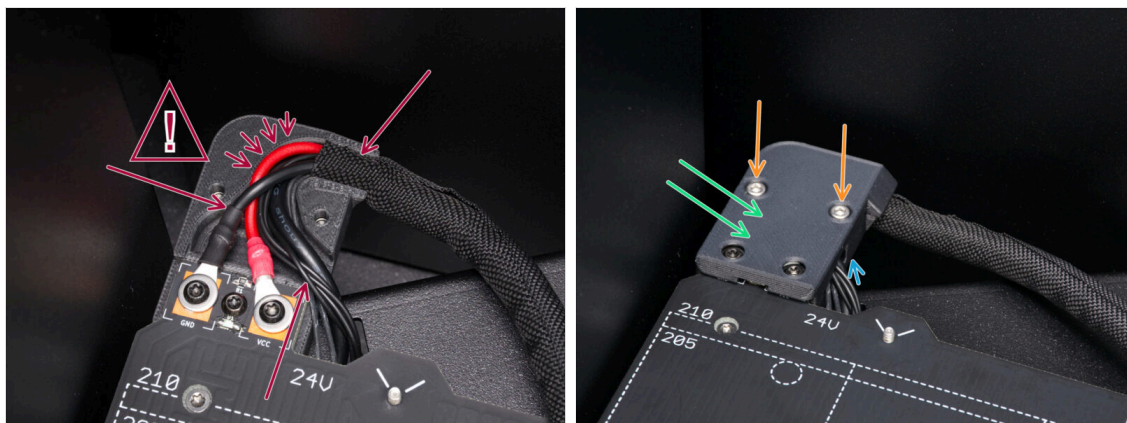

- ⚠ Before closing the cover, make sure **no wires are sticking out to prevent them from being pinched** by the top cover.
- 🟢 Place the Bed-cable-cover-top over the heatbed cables and align it.
- 🟠 Secure the Bed-cable-cover-top in place with the M3x10 screw.
 - 🔵 While tightening, **hold the M3nN nuts** in the lower part to prevent them from falling out.

PASSO 28 Guiding the heatbed cable bundle I.

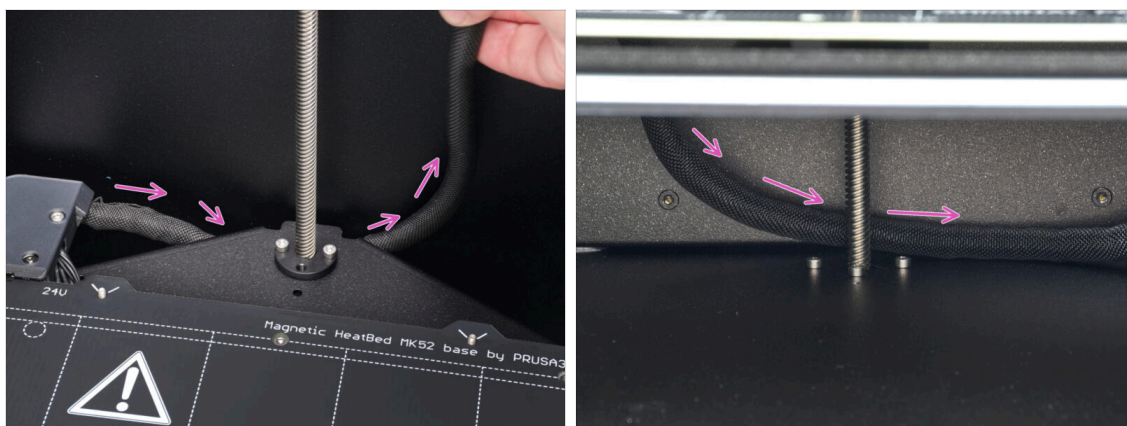

- 🟡 Lead the heatbed cables under the heatbed and **behind the Z-axis threaded rod**.

PASSO 29 Guiding the heatbed cable bundle II.



- Route the cables through the rear panel one by one in the following order:
 - 1. Offset sensor cable
 - 2. LED RGB cable
 - 3. Heatbed thermistor cable
 - Finally, route the heatbed power cables (black and red).
- Push the heatbed cables and the textile sleeve through the grommet hole.
 - No more than 1 cm (0.39 in) of the textile sleeve should protrude from the back side.

PASSO 30 Fissare la guaina in tessuto

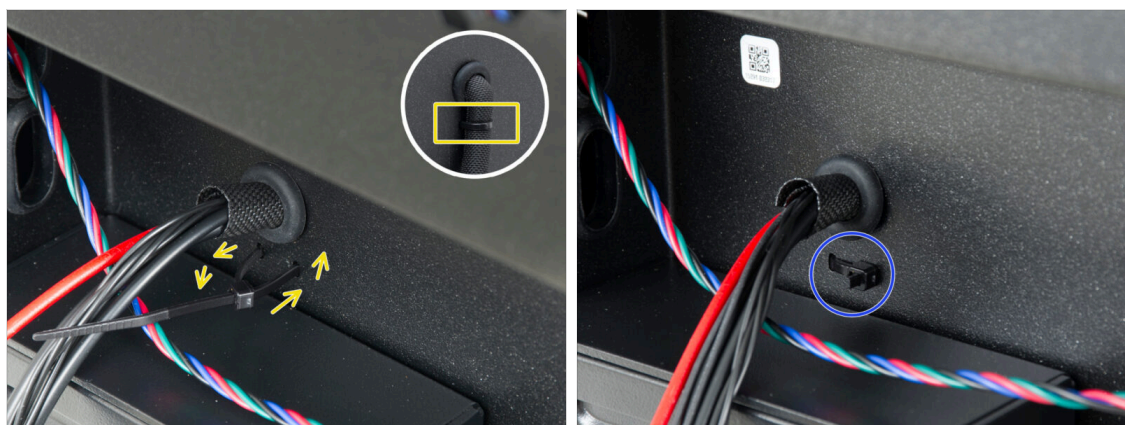

- Fai passare la fascetta attraverso i due fori sotto i cavi del piano riscaldato e crea un anello intorno al fascio di cavi del piano riscaldato (guaina in tessuto) all'interno.
- Stringi bene la fascetta e taglia la parte in eccesso.

PASSO 31 Removing the Bed-stop-rear

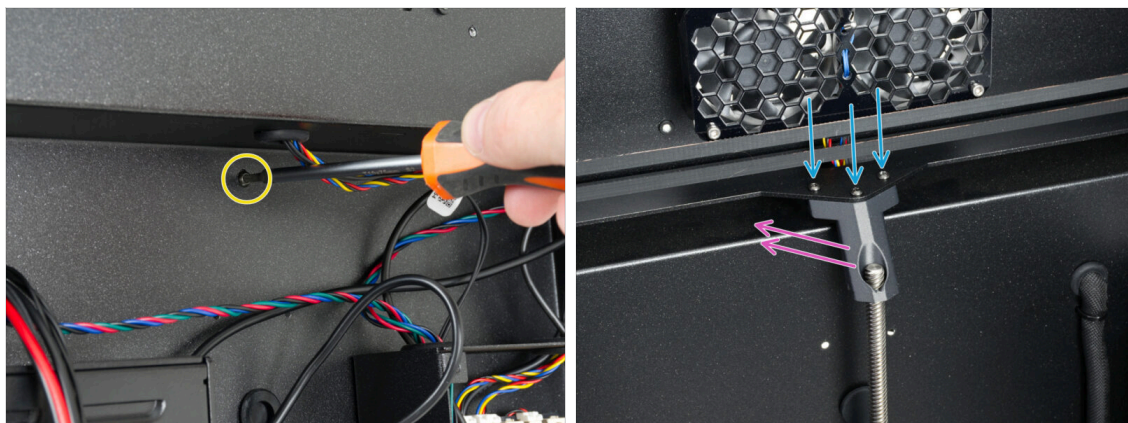

- Use a Torx key to remove the M3x8rT screw on the rear side of the printer.
- Remove the three M3x8rT screws.
- Remove the Bed-stop-rear.

PASSO 32 INDX-C1-Bed-stop-rear: parts preparation

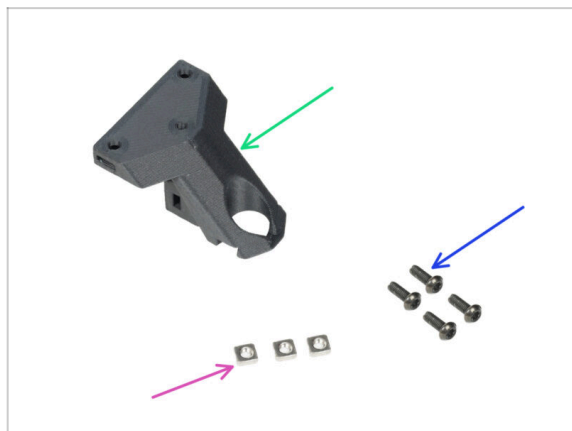

- **Per le fasi successive, prepara:**
- INDX-C1-bed-stop-rear (1x)
- M3x8rT screw (4x) *removed earlier*
- M3nS nut (3x) *found in the fasteners 2/2 bag*

PASSO 33 Assembling the Bed-stop-rear



- The new Bed-stop-rear is labeled with an X.
- Insert the M3nS nut into the Bed-stop-rear and push it fully down.
 - Always check through the screw hole that the nut is properly aligned.
- From the same side, insert the second M3nS nut all the way into the part.
- From the opposite side, insert the third M3nS nut into the part.

PASSO 34 Installing the new Bed-stop-rear



- Place the Bed-stop-rear onto the rear Z motor threaded rod and rest it against the edge of the rear panel.
- Mount the Bed-stop-rear onto the Z-Axis threaded rod and secure it in place with three M3x8rT screws.
 - ⓘ The middle screw threads into the plastic, not into a nut. Expect slight resistance while tightening.

PASSO 35 Assicurare il Bed-stop-rear

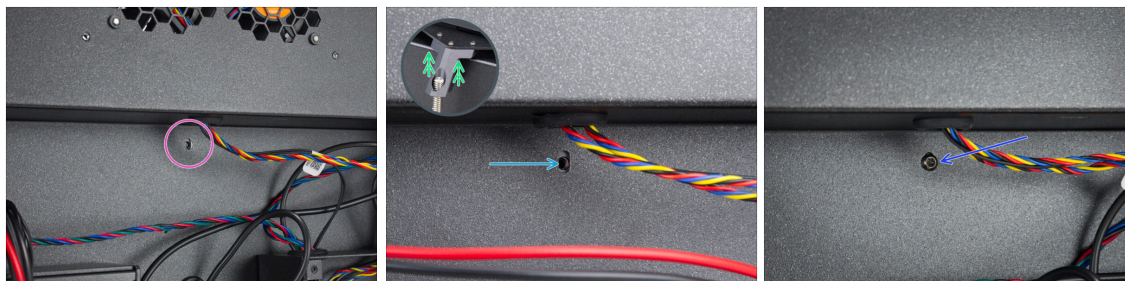

- Move to the back of the printer.
- Locate the oval screw hole under the cooling fans.
- The oval hole must be flush with the hole in the Bed-stop part on the opposite side.
 - Per compensare, alza leggermente la parte posteriore del gruppo CoreXY, solo di qualche millimetro.
- After aligning the holes, secure them with the M3x8rT screw.

PASSO 36 Connecting the RGB LED + offset sensor cables

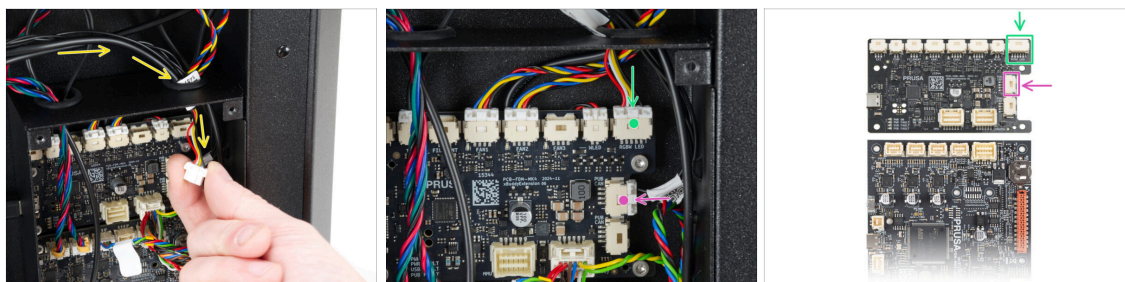

- Route the RGB LED cable and the offset sensor cable through the upper right opening in the xBuddy box.
- Plug the **RGB LED connector** into the **rightmost RGBW LED slot** on the xBuddy Extension board.
- Plug the **offset sensor cable** into the **upper right PUB CAN slot** on the xBuddy Extension board.

PASSO 37 Collegamento dei cavi del piano riscaldato

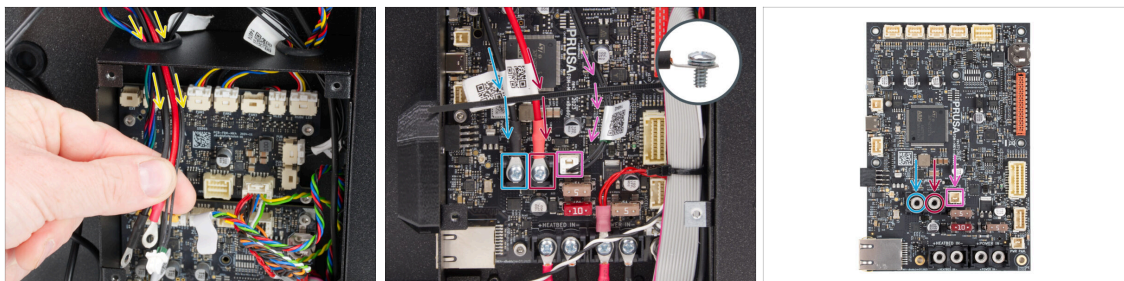

- Route the heatbed power cables and the heatbed thermistor cable through the **left opening** at the top of the xBuddy box.
- Using the 6-32 terminal screw connect the **black** power cable to the **left** terminal slot on the xBuddy board. Tighten firmly.
- Using the 6-32 terminal screw to connect the **red** power cable to the **right** terminal slot. Tighten firmly.
- Plug the heatbed thermistor connector to the slot next to the power terminals.

PASSO 38 Haribo time

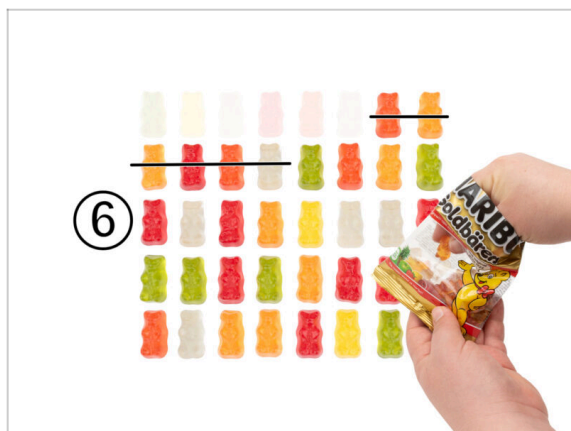

- Now is the time for a well-deserved boost.
- Mangia sei orsetti gommosi.

PASSO 39 Fatto



- Congratulations! You have just upgraded the Z-axis.
- Andiamo al prossimo capitolo.

4. INDX Toolhead & Side filament sensors



PASSO 1 Attrezzi necessari per questo capitolo

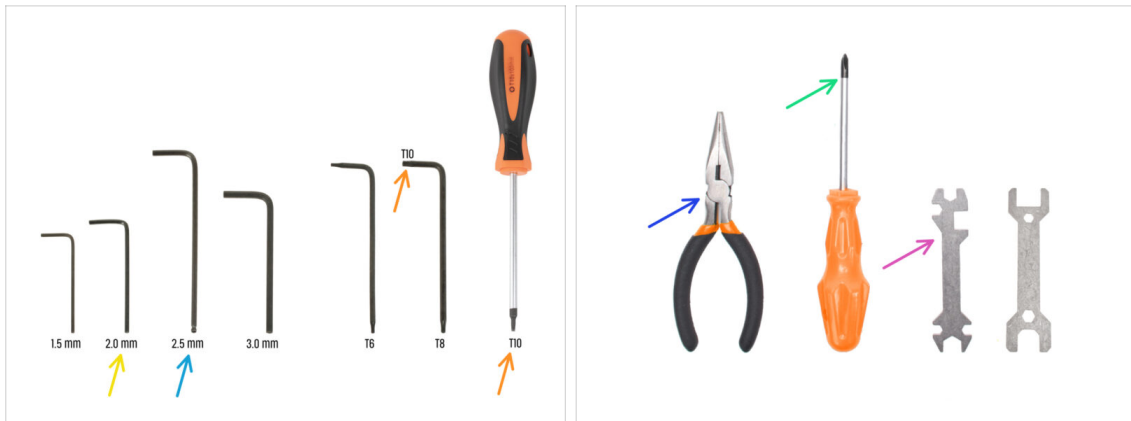

● **Per questo capitolo prepara:**

- 2.0mm Allen key
- Chiave a brugola da 2.5mm
- T10 key / screwdriver
- Needle-nose pliers or flush cutters for cutting zip ties
- PH2 screwdriver
- Universal wrench

PASSO 2 Loosening the belts

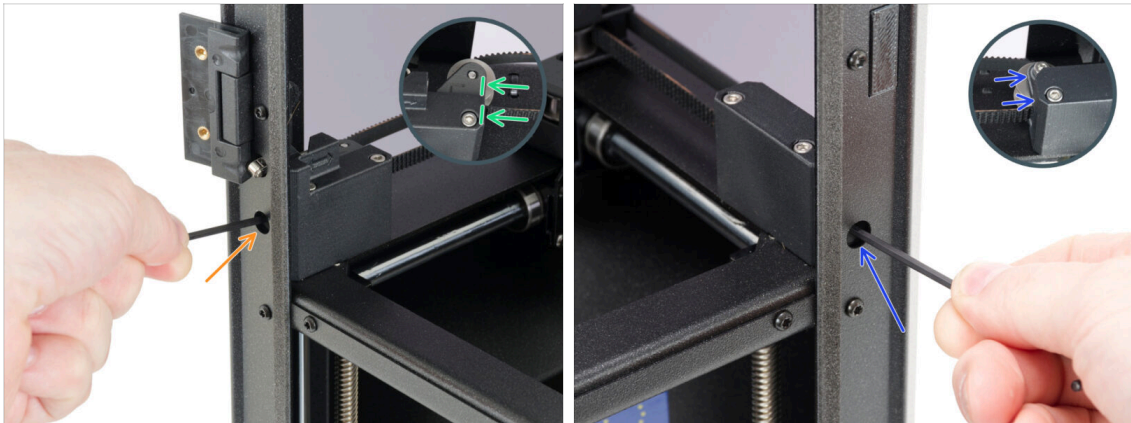

- The belt tensioning screw is located in the front left profile under the upper hinge.
- Using a 2.5 mm Allen key, loosen the tensioning mechanism until the idler is flush with the tensioner.
- 🔧 Typically, this requires 8–10 turns. **Be careful not to loosen the screw all the way!**
- ⓘ If you accidentally loosen the belt tensioning screw all the way, ensure the nut inserted into the back of the tensioner does not fall out.
- Move to the opposite side and loosen the tensioning mechanism until the idler is flush with the tensioner.

PASSO 3 Rilascio delle cinghie

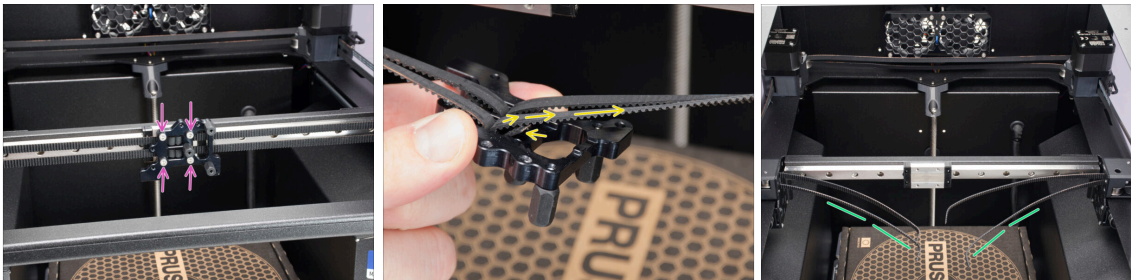

- Using the 2.5mm Allen key, remove four M3x10 screws securing the Nextruder holder.
- Disengage all four belt ends from the Nextruder holder slots.
- Remove the Nextruder holder.
- ⓘ This part will no longer be needed.
- Let the loosened belts hang freely.
- ⚠ **CAUTION: Do not pull on the belts, as they could slip out of the motor pulleys and require full disassembly for reinstallation.**

PASSO 4 Gantry aligner tool: parts preparation

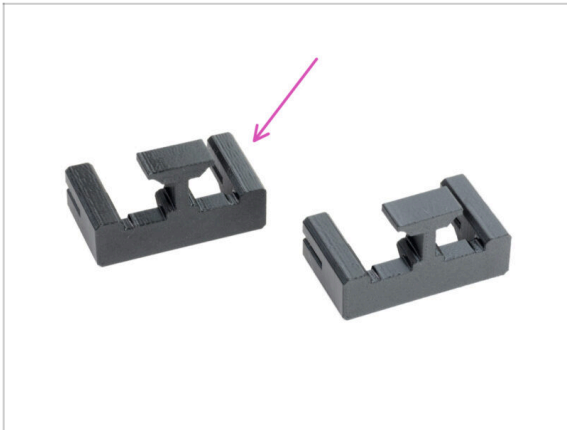

- Per i seguenti passi prepara:
- ◆ INDX-Gantry-aligner-tool (2x) found in the Position tools bag

PASSO 5 Installing the Gantry-aligner-tool - right

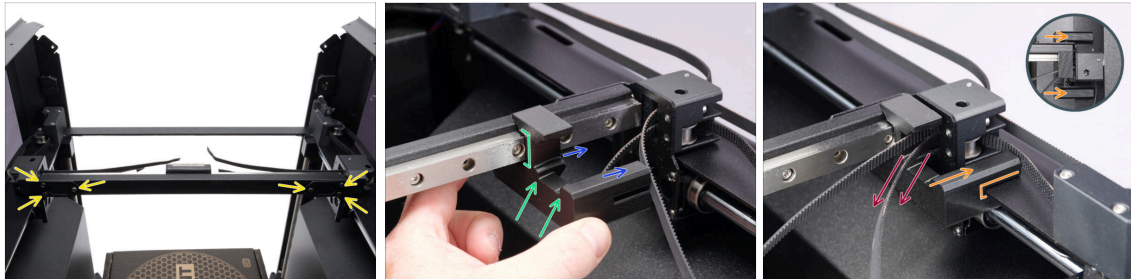

- Start by slightly loosening three screws on the back of the gantry on each side.
- Place one of the the Gantry-aligner-tool on the **front right side** of the X-axis, aligning the **linear rail with the matching cutout**.
- ⓘ Both Gantry-aligner-tools are identical.
- The fork must face the pulleys.
- Slide the Gantry-aligner-tool fully onto the gantry frame profile, ensuring the cutouts engage.
- Route both free belt ends through the open space above the tool.

PASSO 6 Installing the Gantry-aligner-tool - left

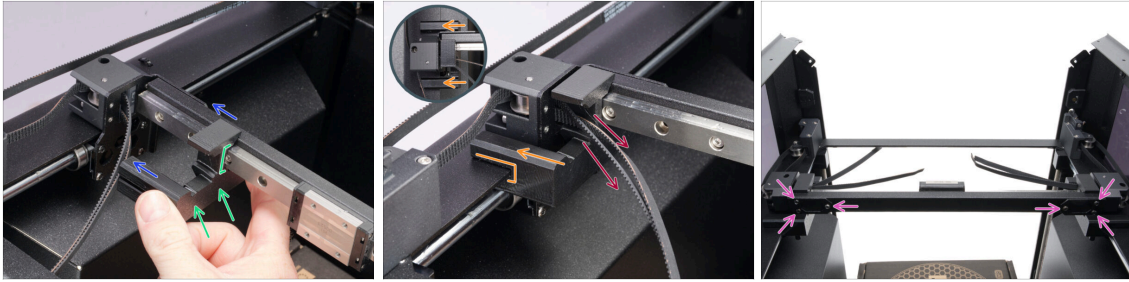

- ◆ With each Gantry-aligner-tool in place, tighten the three screws on each side of the back of the gantry.
- ◆ Place the Gantry-aligner-tool on the **front left side** of the X-axis, aligning the **linear rail with the matching cutout**.
- ◆ The fork must face the pulleys.
- ◆ Slide the Gantry-aligner-tool fully onto the gantry frame profile, engaging the cutouts.
- ◆ Route both free belt ends through the open space above the tool.

PASSO 7 Allineamento della guida lineare

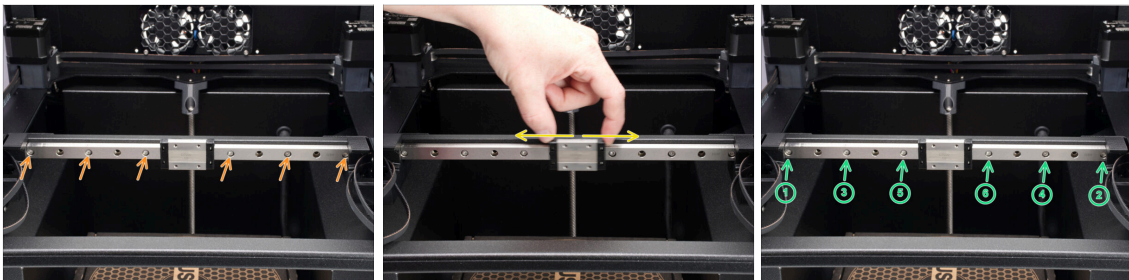

- ◆ Using a 2.5 mm Allen key, loosen all six screws securing the linear rail.
- ◆ Move the linear bearing back and forth along the full length of the axis.
- ◆ **Firmly tighten** all six screws one by one in the **specified order**.

PASSO 8 Removing the Gantry-aligner-tool

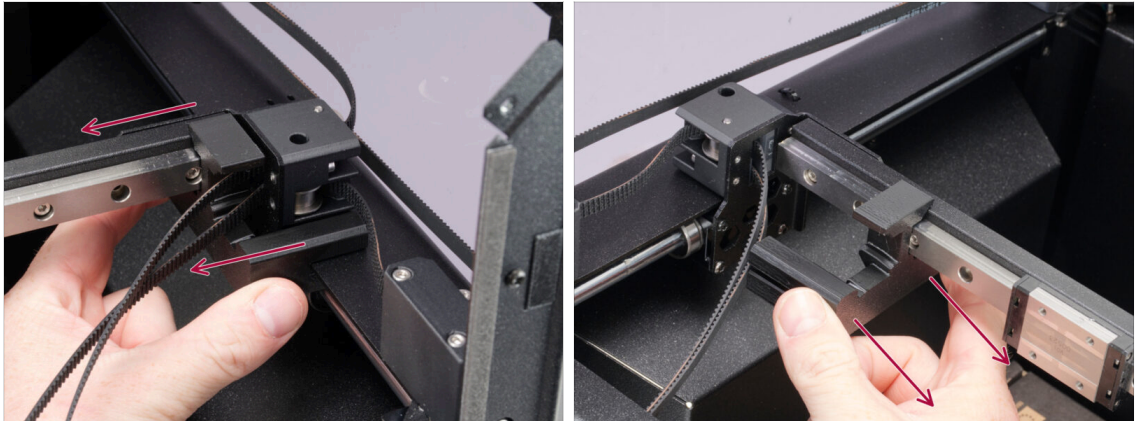

- ◆ Remove both Gantry-aligner-tools from the printer.
- ⓘ This part will no longer be needed.

PASSO 9 Print head mount: parts preparation

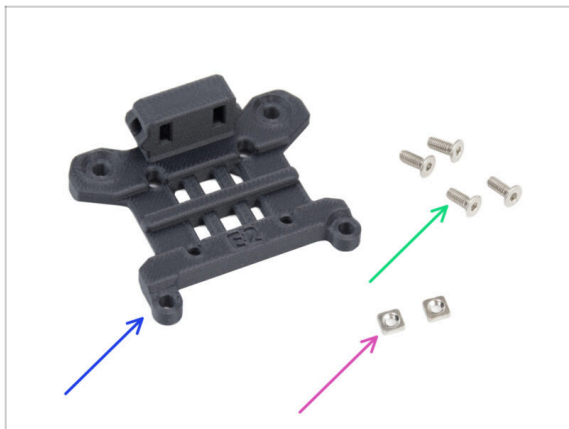

- ◆ Per i seguenti passi prepara:
- ◆ INDX-Head-mounting-plate (1x)
found in the Toolhead bag
- ◆ M3x8b screw (4x) *found in the Fasteners 1/2 bag*
- ◆ M3nS nut (2x) *found in the Fasteners 2/2 bag*

PASSO 10 Securing the belts

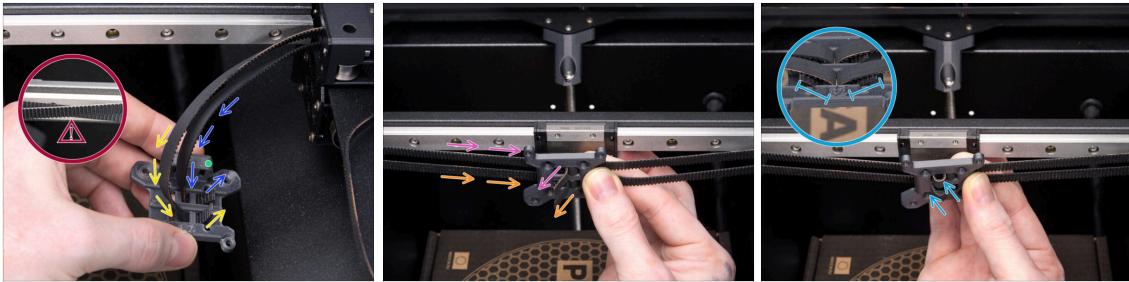

- ◆ Hold the Head-mounting-plate in the correct orientation, using the protrusion as a guide.
- ◆ From the right side, route the **lower belt** through the **rear center opening** in the Head-mounting-plate, around the post, and back out. It must extend **4-5 teeth**.
- ◆ Route the **upper belt** through the **front center opening** in the Head-mounting-plate, around the post, and back out. It must extend **4-5 teeth**.
- ⚠ **Make sure the belts are not crossed.**
- ◆ **Hold the right belts in place with your thumb to prevent them from slipping out.**
- ◆ Route the **upper belt** through the **front center opening** out (down) of the Head-mounting-plate. It must extend **6-7 teeth**.
- ◆ From the left side, route the **lower belt** through the **rear center opening** out (down) of the Head-mounting-plate. It must extend **6-7 teeth**.
- ◆ Insert the **belt ends from the left side** into the **left opening** and press them in. Leave 4-5 teeth protruding on from the rear side of the Head-mounting-plate.

PASSO 11 Installing the Head-mounting-plate

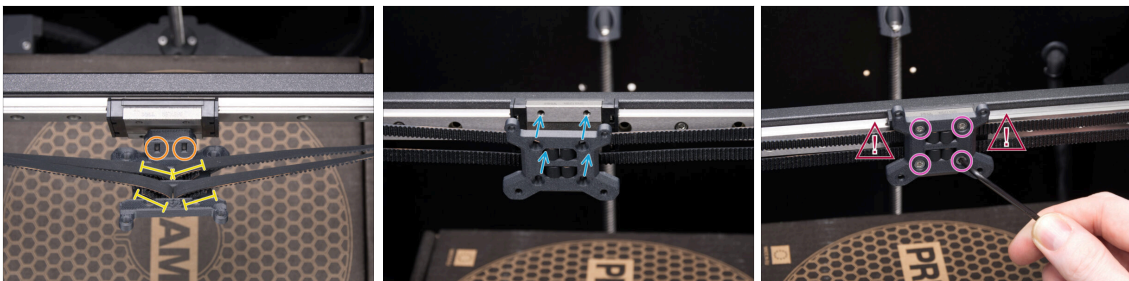

- ◆ Double-check that **all four belt ends protrude 4-5 teeth** inward.
- ◆ Insert two M3nS nuts into the protrusion of the Head-mounting-plate.
- ◆ Place the Head-mounting-plate against the linear bearing and align it with the holes.
- ◆ Using a 2.0 mm Allen key, secure the part with four M3x8b screws. Tighten the screws **firmly, but gently**.
- ⚠ **Check on both sides that the belts are correctly routed through their channels and are not pinched anywhere.**

PASSO 12 Regolazione delle cinghie



- Locate the tensioning screws in the front left and front right profiles.
- Using a 2.5 mm Allen key, tension the belts so that both tensioning mechanisms are in approximately the same position as shown in the picture - about 8 mm (0.31 in) from the edge of the tensioner.

i Typically, this requires 8–10 turns.

📌 Final fine-tuning will be done in the final chapter.

PASSO 13 INDX Toolhead assembly: Parts preparation



- **Per il prossimo passo, prepara:**
- INDX Toolhead (1x) *found in the main box*
- Cable-strain-relief (1x) *found in the Cable strain relief bag*
- M3x16T screw (1x) *found in the Cable strain relief bag*

PASSO 14 Attaching the cable strain relief

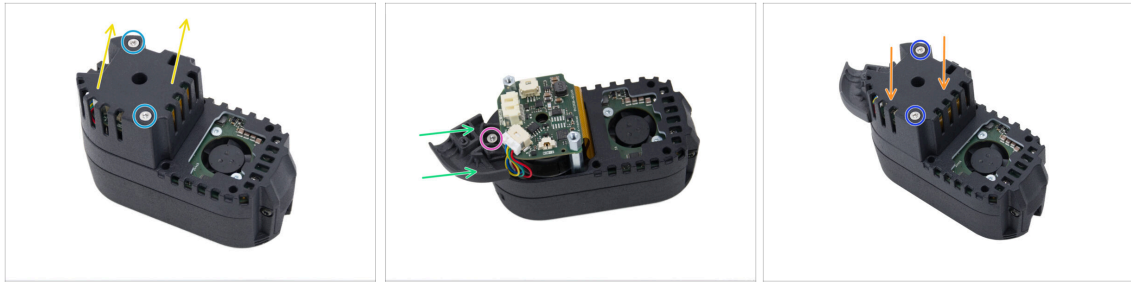

- Use the T10 key/screwdriver to remove two M3x6T screws.
- Remove the INDX Toolhead cover.
- Attach the front cable strain relief to the INDX Toolhead.
- Secure the front cable strain relief with the M3x16T screw.
- Carefully attach the INDX Toolhead cover. **Ensure that no cables are pinched.**
- Secure the cover in place with the two M3x6T screws you removed earlier.

PASSO 15 INDX Toolhead: parts preparation



- **Per i seguenti passi prepara:**
- INDX Toolhead (1x) *that you assembled earlier*
- M3x14 screw (4x) *found in the Fasteners 1/2 bag*

PASSO 16 Mounting the INDX Toolhead

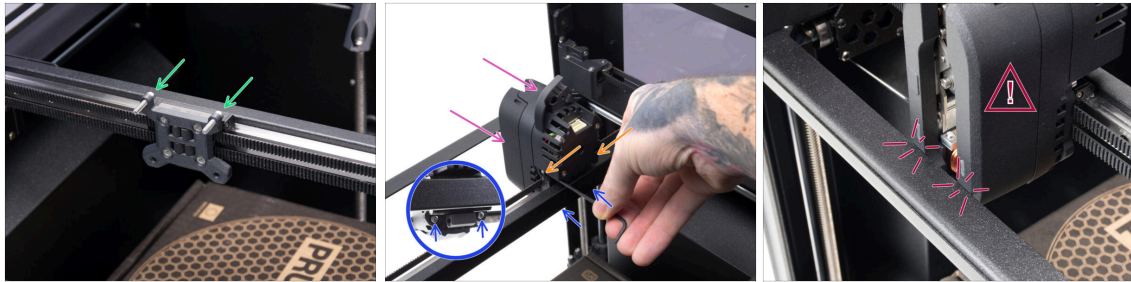

- ◆ From the rear side of the Head-mounting-plate, insert two M3x14 screws into the holes.
 - ◆ From the front side, place the INDX Toolhead onto the Head-mounting-plate as shown in the picture.
 - ◆ Secure it using the upper M3x14 screws and fully tighten them firmly.
 - ◆ Secure the INDX Toolhead by inserting two M3x14 screws into the lower holes and tightening them firmly.
- ⚠ **WARNING:** Avoid contact with the front metal LED holder to prevent damage or scratches to the INDX Toolhead.

PASSO 17 Fan shroud: preparazione dei componenti

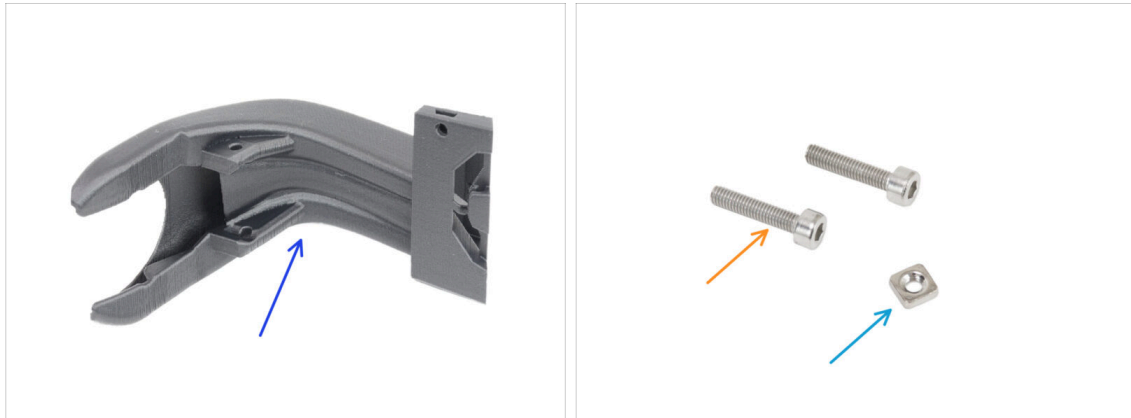

- ◆ **Per i seguenti passi prepara:**
- ◆ INDX-C1-Fan-shroud (1x) *found in the Toolhead bag*
 - ◆ M3x14 screw (2x) *found in the Fasteners 1/2 bag*
 - ◆ M3nS nut (1x) *found in the Fasteners 2/2 bag*

PASSO 18 Attaching the Fan-shroud

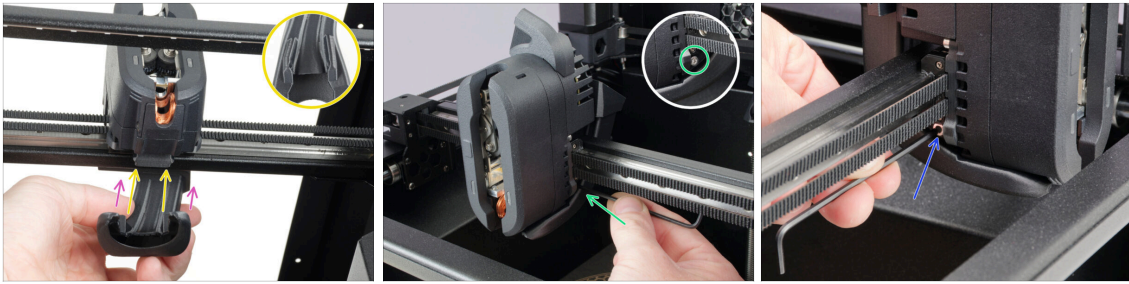

- ◆ Attach the Fan-shroud to the INDX toolhead from below.
- ◆ Note the ridge in the Fan-shroud. This ridge will slide onto the bottom part of the Head-mounting-plate.
- ◆ Secure the Fan-shroud using the M3x14 screw from the right side.
- ◆ Secure it from the left side using an M3x14 screw as well.

PASSO 19 Inserting the nut

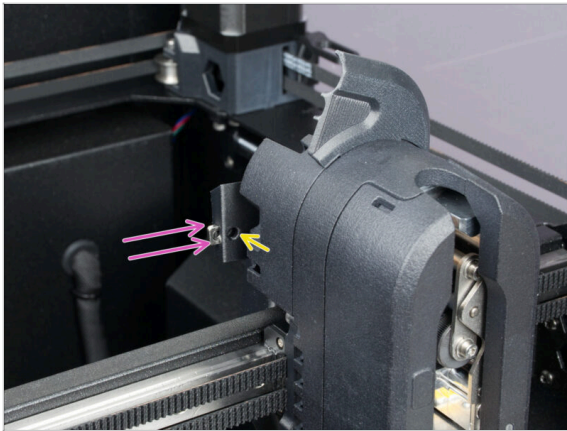

- ◆ Insert an M3nS nut into the protrusion on the left side of the INDX Toolhead.
- ◆ From the front, check through the screw hole that the nut is properly seated.

PASSO 20 Ventola di stampa: preparazione dei componenti

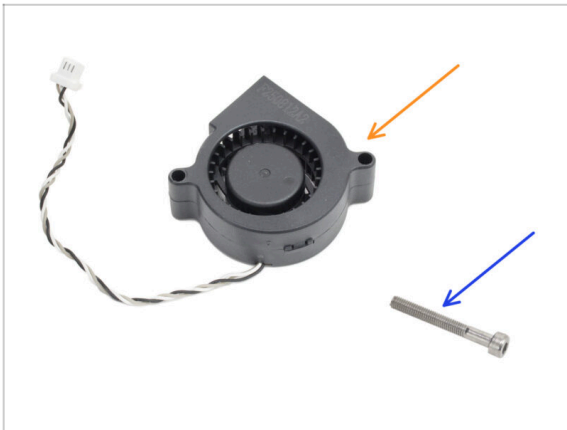

- Per i seguenti passi prepara:
- Print fan (1x) removed earlier
- M3x25 screw (1x) found in the Fasteners 1/2 bag

PASSO 21 Installing the print fan

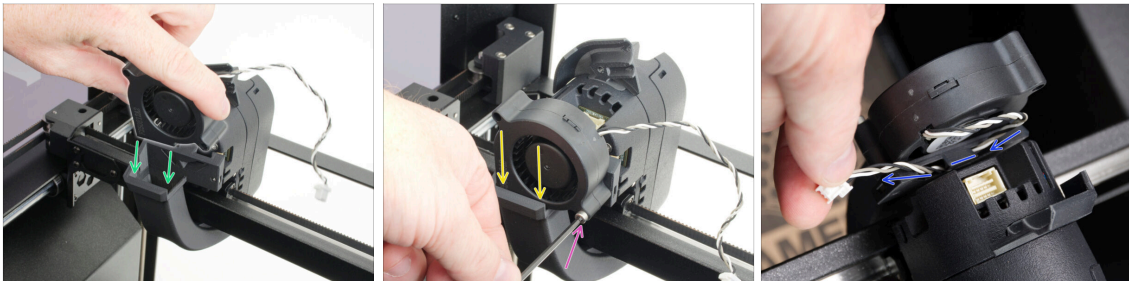

- Look at the INDX Toolhead from the rear side.
- Take the print fan as shown and align it with the Fan-shroud opening.
- Insert the print fan into the Fan-shroud opening.
- Secure it with one M3x25 screw.
- ⚠ Do not overtighten the screw to avoid cracking the fan housing.
- Guide the print fan cable under the cable hook on the Fan-shroud.

PASSO 22 Connettere la ventola di stampa



- Plug the print fan cable into the connector in the INDX Toolhead.
- Keep the cable from **protruding too far to the side**.

PASSO 23 INDX head cable: parts preparation I.



- Per i seguenti passi prepara:**
- Head-cable-clip (1x) *found in the Toolhead bag*
- INDX-C1-Swing-arm-clip *found in the Toolhead bag*
- INDX-C1-Head-cable-cover (1x) *found in the Cable strain relief bag*
- Vite M3x10 (1x) *rimossa in precedenza*
- M3x8rT screw (1x) *found in the Fasteners 2/2 bag*
- M3x8rT self-tapping screw (1x) *found in the Cable strain relief bag*

PASSO 24 INDX head cable: parts preparation II.

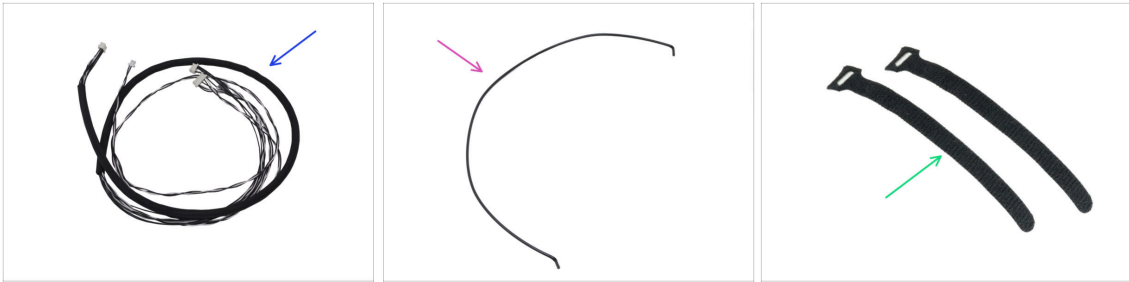

- ◆ INDX head cable (1x) *found in the Cables bag*
 - ◆ Nylon ?????? 4 x 2.5 x 450 (1x) *found in the main box ??????*
 - ◆ Cable tie (2x)
- 📌 Reuse the cable ties you removed earlier.

PASSO 25 Guiding the head cable



- ◆ Now move to the rear side of the printer.
 - ◆ Pass the head cable connector through the lower oval opening on the left side of the rear panel.
 - ◆ Insert most of the braided cable into the printer. The exact length will be adjusted later.
- 📌 Make sure the **grommet does not slide into the printer**. If needed, you can pull it outward for easier handling; it will be reinstalled later.
- ◆ Inside the printer, route the head cable upward through the corner behind the gantry assembly.

PASSO 26 Inserting the Nylon



- In this step, we will insert the nylon into the cable sleeve.
- Insert the Nylon into the cable sleeve near the head cable connector.
 - Ensure that the nylon is completely wrapped inside the sleeve, along with the head cable.
- Continue inserting the nylon into the cable sleeve along the whole length.
- Leave the end of the nylon sticking out from the cable sleeve as shown.
- Tighten the cable sleeve around the head cable and the nylon insert by gently twisting the sleeve.

PASSO 27 Connecting the head cable



- Plug the head cable into the print head. Ensure that the safety latch clicks in place.
- Insert the nylon into the slot in the print head. Ensure that the nylon is inserted all the way in.
- Insert the cables into the channel. Ensure that no cables are sticking out.
- Adjust the textile sleeve so that 1.5 cm (0.59 in) is inside the channel.
- Note the protruding bit on the Head-cable-cover. It will fit into the slot in the INDX toolhead.
- Attach the Head-cable-cover.
- ⚠ **When attaching the Head-cable-cover, ensure you do not pinch or damage any cables.**
- Use the M3x8rT self-tapping screw to secure the Head-cable-cover in place.

PASSO 28 Attaching the head cable

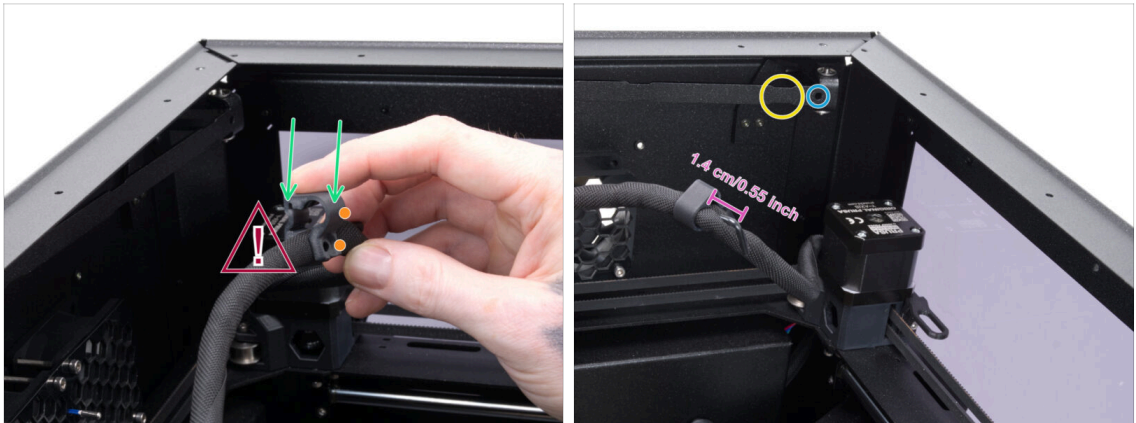

- Gently open up the **Swing-arm-clip** and attach it to the head cable with the nylon inside of the cable sleeve.
- ⚠ Proceed carefully. **Do not break the Swing-arm-clip when attaching it to the head cable.**
- Pay attention to the correct orientation; the protruding side of the clip and the side with the cut-out for the screw must face the front of the printer.
- Once the Swing-arm-clip is on the head cable, adjust it so the distance between the clip and the bend in the nylon is 1.4 cm / 0.55 inch
- Locate the rightmost narrowing on the swing arm. We will mount the Swing-arm-clip there in the next step.
- Note the hole in the swing arm. This is where we will insert the nylon end in the next step.

PASSO 29 Securing the swing arm clip

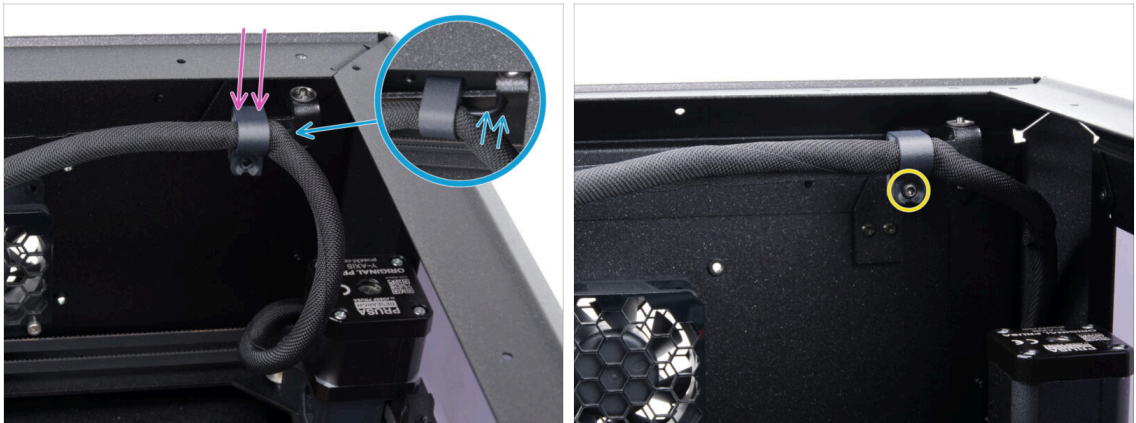

- ◆ Attach the Swing-arm-clip to the swing arm from the top. Ensure that the **clip is placed on the rightmost narrowing** on the swing arm.
- ◆ Insert the end of the nylon into the hole in the swingarm.
- 🔗 Ensure that the cable sleeve is not pinched where the nylon is sticking out.
- ◆ With the Swing-arm-clip and the nylon in the correct positions, secure the clip in place with the M3x8rT screw.

PASSO 30 Securing the main cable



- ◆ Wrap the cable tie around the head cable and the middle narrowing of the swing arm.
- ◆ Tighten the cable tie and wrap the excess strap around it.
- ◆ Secure the head cable with the cable tie around the leftmost narrowing on the Swing arm.

PASSO 31 Installing the Head cable clip

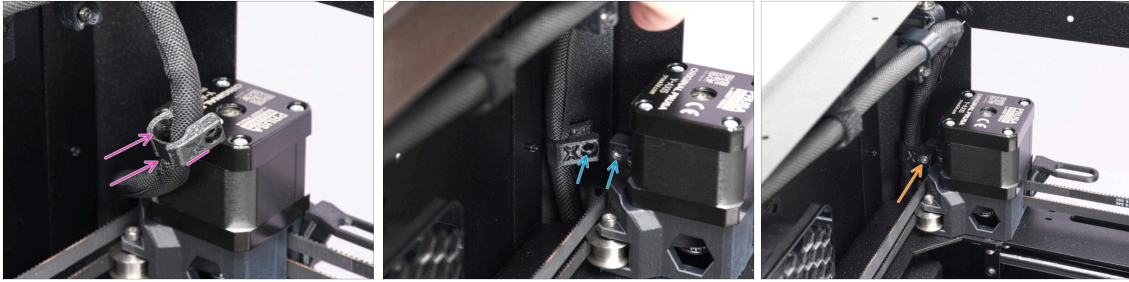

- Make sure that the cable sleeve is tightly wrapped around the cables. Twist the cable sleeve slightly to make it tighter.
- Carefully open the Head-cable-clip and attach it to the head cable.
- 🔗 **Pay attention to the correct orientation**, using the "X" symbol and the cutout for the screw head as a guide.
- Align the Head-cable-clip with the hole on the Y motor mount protrusion.
- Secure the part using an M3x10 screw.
- ⓘ *Pro tip:* Pre-thread the M3x10 screw into the part after snapping it onto the cable.

PASSO 32 Connecting the head cable: parts preparation

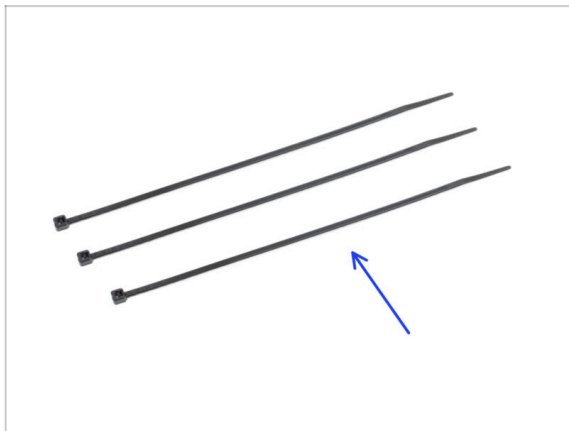

- **Per i seguenti passi prepara:**
- Fascetta (3x)

PASSO 33 Inserimento delle fascette

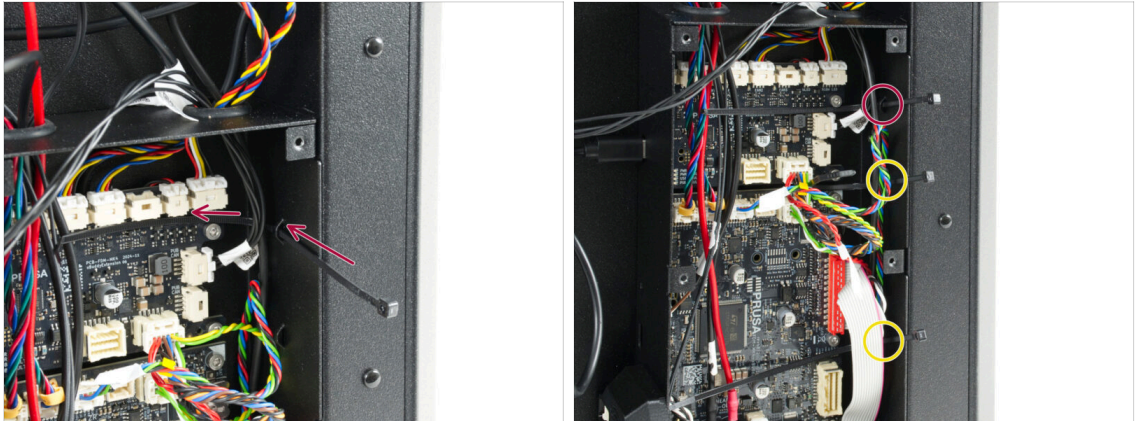

- Pass the zip tie through the upper perforation in the xBuddy box. The zip tie must run underneath all cables.
- Do the same for the other two perforations.

PASSO 34 Connecting the head cable

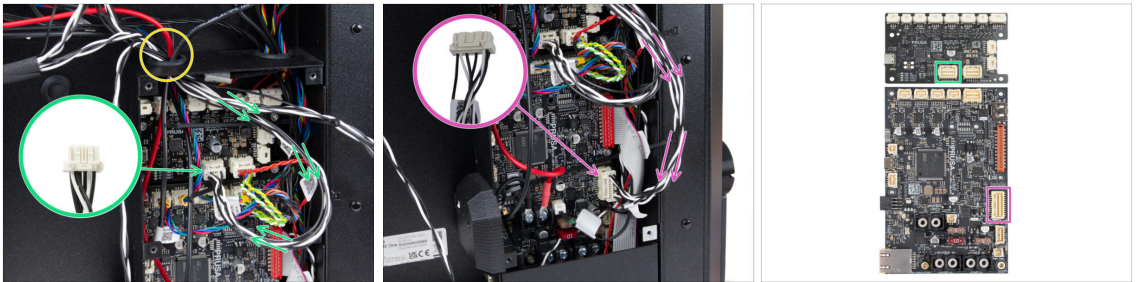

- Guide the head cable through the left opening in the xBuddy box.
- Plug the branched head cable connector as follows:
 - **Narrow connector:** plug it into the **MMU**-labeled slot on the **xBuddy Extension** board.
 - **Wide connector:** plug it into the **Nextruder**-labeled slot on the **xBuddy** board.
- Guide the main cable **under** the grey xLCD ribbon cable.

PASSO 35 Fissare i cavi

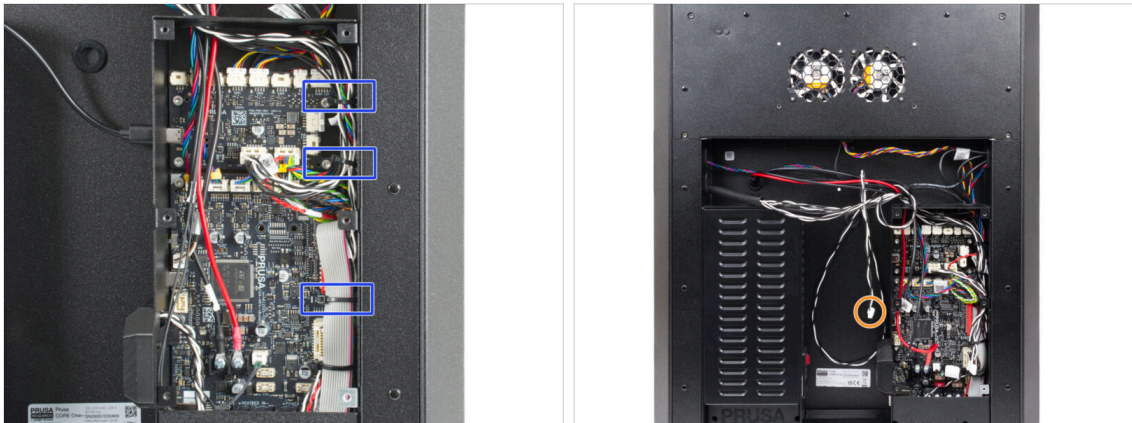

- Adjust the cable management according to the picture. Route all cables along the edges.
- Tighten the zip ties on the right side and trim the excess.
- ⚠ **Do not overtighten to avoid damaging the cables.**
- **Leave the last connector of the head cable unplugged.** This will be done later on when we connect the dock fan.
 - We recommend hanging the cable on the other cables so it does not get damaged when turning the printer.

PASSO 36 Haribo time!



- 📌 Time for a little yummy gummy break.
- Take a small reward break: eat five gummy bears.

PASSO 37 INDX PTFE holders: parts preparation

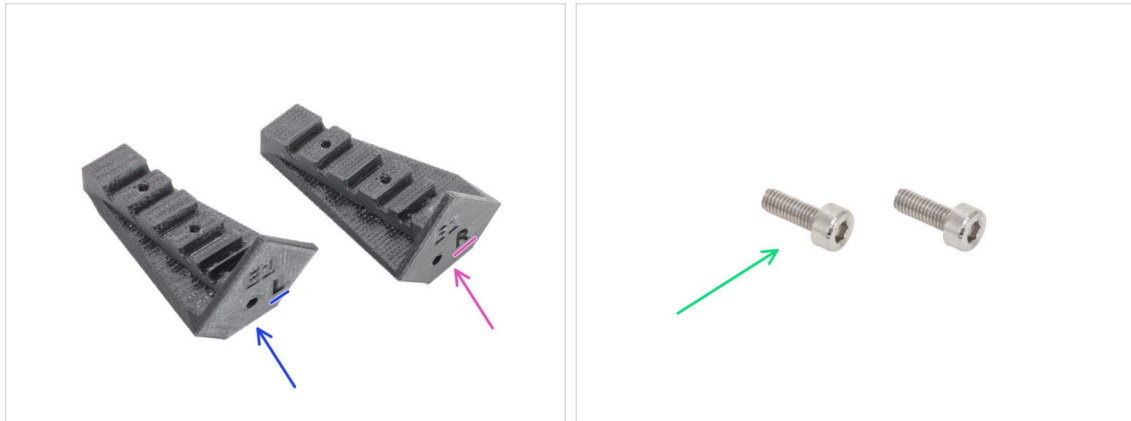

- Per i seguenti passi prepara:
- INDX-PTFE-holder-left (1x) *marked "L"*
- INDX-PTFE-holder-right (1x) *marked "R"*
- Vite M3x10 (2x) *rimossa in precedenza*

PASSO 38 Installing the PTFE-holder-left



- Using the 2.5mm Allen key release and remove two M3x4 screws securing the top rear profile.
- Take the PTFE-holder-**left** and insert one M3x10 screw.
- Align the PTFE-holder-left with the **left** hole on the top rear profile.
- Join both parts by fully tightening the M3x10 screw.

PASSO 39 Installing the PTFE-holder-right

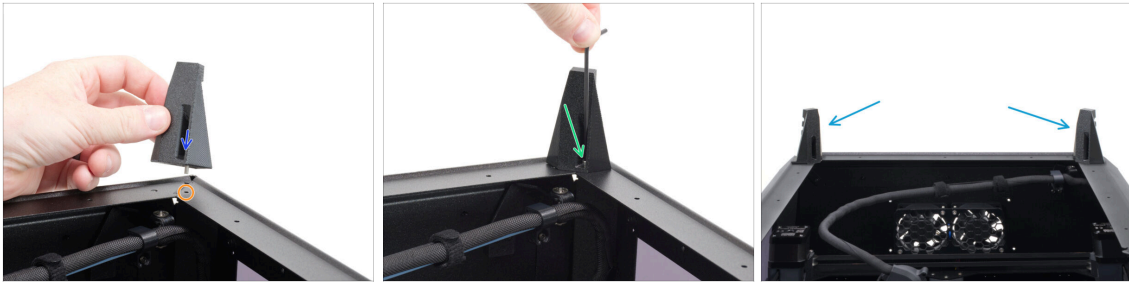

- ◆ Take the PTFE-holder-**right** and insert one M3x10 screw.
 - ◆ Align the PTFE-holder-right with the **right** hole on the rear profile.
 - ◆ Join both parts by fully tightening the M3x10 screw.
 - ◆ Visually compare both PTFE holders with the picture.
- ⚠ Now move outside the printer area, as you will prepare the filament sensors.

PASSO 40 Side filament sensors: parts preparation



- ◆ **Per i seguenti passi prepara:**
- ◆ INDX-C1-FS-top (1x) *found in the Filament holder L bag*
 - ◆ INDX-C1-FS-top (1x) *found in the Filament holder R bag*
 - ⓘ Note that each part has a different position numbering.
 - ◆ Sleeve 2x5 (4x) *found in the Fasteners Tools INDX bag*
 - ◆ Collet (4x) *found in the Fasteners Tools INDX bag*
 - ◆ M3x12cT screw (2x) *found in the Fasteners 2/2 bag*
 - ◆ Magnet 3.2 x 5 (2x) *found in the Fasteners Tools INDX bag*

PASSO 41 Inserimento delle guaine



- Insert the 2x5 sleeves into the indicated positions in the square opening of the FS-top.
- Push each sleeve **fully into place** using a non-sharp tool. It will click when correctly seated.
- **Check from the side that each sleeve is in the correct position:**
 - The sleeve is in the correct position.
 - The sleeve needs to be pushed further.
- Repeat this procedure for all the sleeves on both FS-top parts.

PASSO 42 Inserting the collets



- Position the FS-top with the square openings facing down.
- Insert the collets into the top openings.
- Use this procedure for both FS-top parts.

PASSO 43 Installare i magneti



- ◆ Insert the 5x2 magnet into the FS-top with the cut-out facing up.
- ◆ Secure the magnet with the M3x12cT screw.
 - ⓘ The magnet may stick to the T10 key during tightening; hold it in place by hand.
- ◆ Repeat the same process to install the remaining magnets on both FS-top parts.

PASSO 44 Assembling the FS: parts preparation I



- ◆ **Per i seguenti passi prepara:**
- ◆ Steelball 7mm (8x) found in the *Fasteners Tools INDX bag*.
- ◆ Magnet 7x8 (8x) found in the *Fasteners Tools INDX bag*

PASSO 45 Assembling the FS: parts preparation II



● **Per i seguenti passi prepara:**

- INDX-C1-FS-holder (1x) *found in the Filament holder L bag*
- INDX-C1-FS-holder (1x) *found in the Filament holder R bag*
- Filament sensor board Left (1x) *found in the electronics box*
- Filament sensor board Right (1x) *found in the electronics box*
- M3x12cT screw (8x) *found in the Fasteners 2/2 bag*

PASSO 46 Inserting the steel balls



- Insert one steelball 7mm into each round hole.
- Repeat the process with the second FS-top part.

PASSO 47 Attaching the magnets

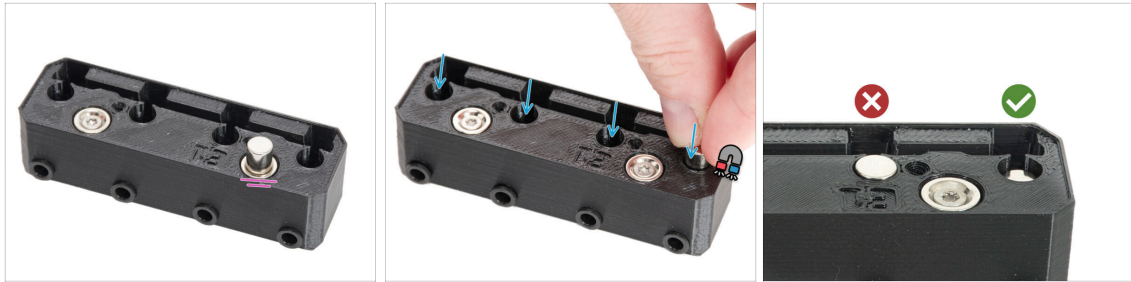

- i **The magnets are quite strong.** Make sure that you keep both parts far from each other.
- Place one of the 7x8 magnets onto the 5x2 magnet. Note which side **attracts the magnet**.
- Insert the magnet in the same hole as you placed the steelball 7mm.
 - ⚠ **Make sure that you insert the magnet with the attracting side going first.**
- **Check that you have the correct position of the magnets:**
 - **NOT OK:** When the **magnet is poking out**, it needs to be flipped and inserted again correctly.
 - **OK:** The **magnet is seated flush** in the hole.

PASSO 48 Assembling the FS-top left

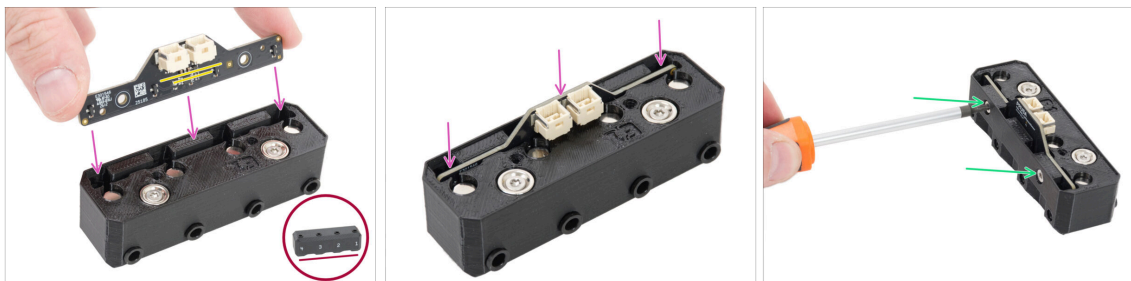

- Prepare the FS-top assembly (**positions 4-1**).
- Insert the filament sensor board **LEFT** (with two connectors) into the ridge in the filament sensor holder top.
 - Make sure the connectors are correctly oriented relative to the printed part.
 - Insert the part fully down.
- Secure the part using two M3x12cT countersunk screws.

PASSO 49 Assembling the FS-top right

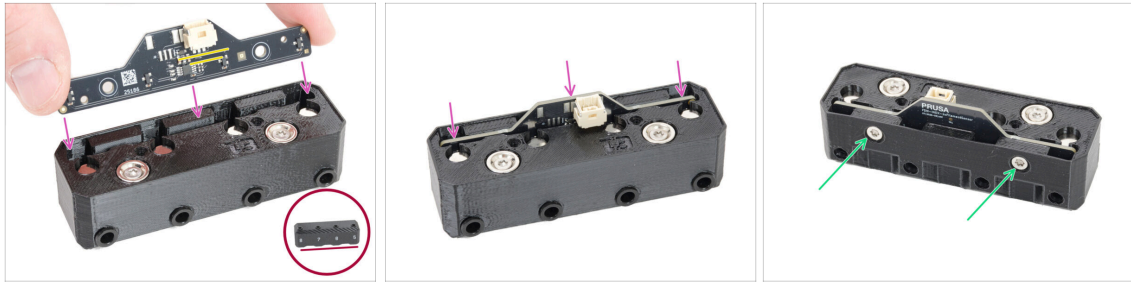

- ◆ Prepare the FS-top assembly with the **(positions 8-5)**.
- ◆ Insert the filament sensor board **RIGHT** (with one connector) into the ridge in the filament sensor holder top.
 - ◆ Make sure the connector are correctly oriented relative to the printed part.
 - ◆ Insert the part fully down.
- ◆ Secure the part using two M3x12cT countersunk screws.

PASSO 50 Covering the filament sensor - left



- ◆ Let's start with the left filament sensor assembly (positions 4-1).
- ◆ Place the FS-holder onto the filament sensor assembly, ensuring the **connectors pass through the rectangular opening**.
- ◆ Use the two M3x12cT screws to secure the board in place. Tighten them firmly.

PASSO 51 Covering the filament sensor - right



- Prepare the filament sensor assembly right (positions 8-5).
- Place the FS-holder onto the filament sensor assembly, ensuring the **connector pass through the rectangular opening**.
- Use the two M3x12cT screws to secure the board in place. Tighten them firmly.

PASSO 52 PTFE tubes - left side: parts preparation



- **Per i seguenti passi prepara:**
- Filament sensor cable (2x) *found in the Cables bag*
- 3x12sT screw (2x) *found in the Fasteners 2/2 bag*
- PTFE tube 4 x 2.5 x 880 (4x) *found in the main box*

PASSO 53 Preparing the filament sensor - left



- ◆ Remove the upper center nylon rivet from the left transparent side panel.
- ◆ Insert a 3x12sT screw from the inside into the rivet hole.
- ◆ Take the filament sensor assembly with the two connectors (positions 4-1) and connect the two filament sensor cables to it.
- ⓘ Both ends of the cable are identical and can be connected interchangeably.
- ◆ Set the right filament sensor (positions 8-5) aside for now. You will need it later.
- ◆ Guide the cables out through the cable channels on the left side.

PASSO 54 Mounting the filament sensor - left

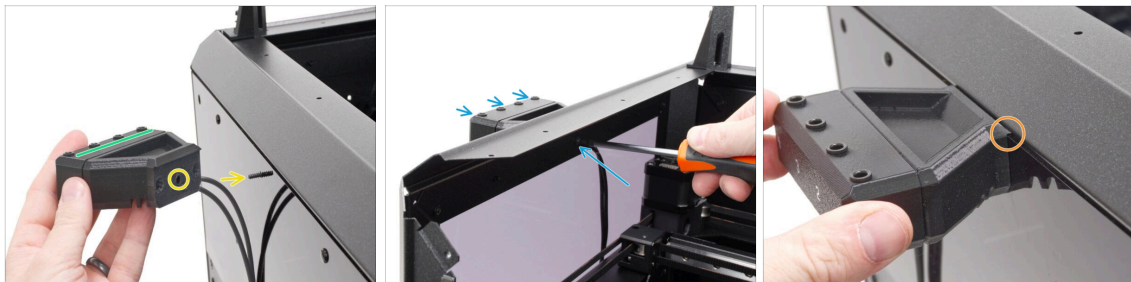

- ◆ Align the left filament sensor assembly with the protruding 3x12sT screw.
- ◆ Ensure correct orientation - the collets must face upward.
- ◆ Fully tighten the screw to secure the assembly. **Make sure that:**
 - ◆ The tab along the top edge is seated in the gap above the transparent side panel.

PASSO 55 Connecting the PTFE tube - left

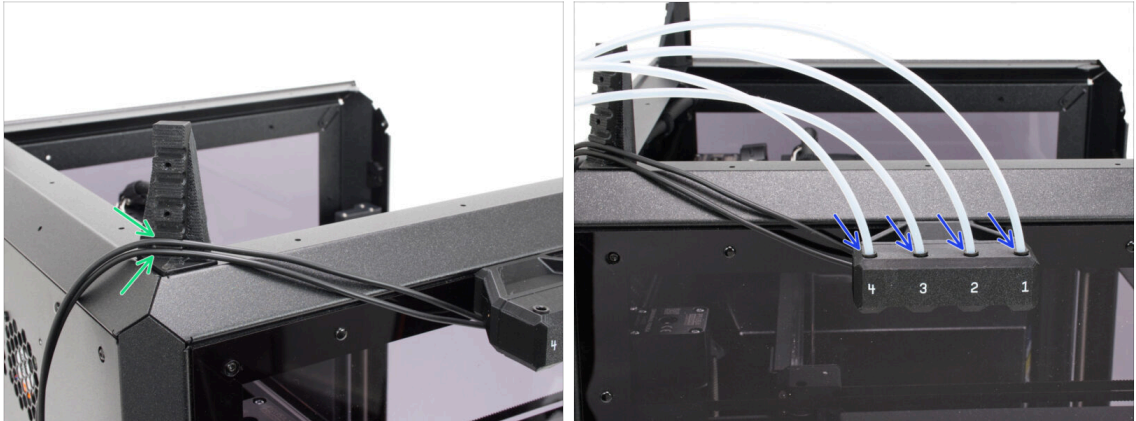

- Insert both filament sensor cables into the lower cable channels in the PTFE-holder.
 - The cables should neither sag nor be under tension along the route.
- Insert four PTFE tubes into the collects in the filament sensor.
 - Gently pull on the tube to verify it is locked in the collet.

PASSO 56 PTFE measurement: parts preparation

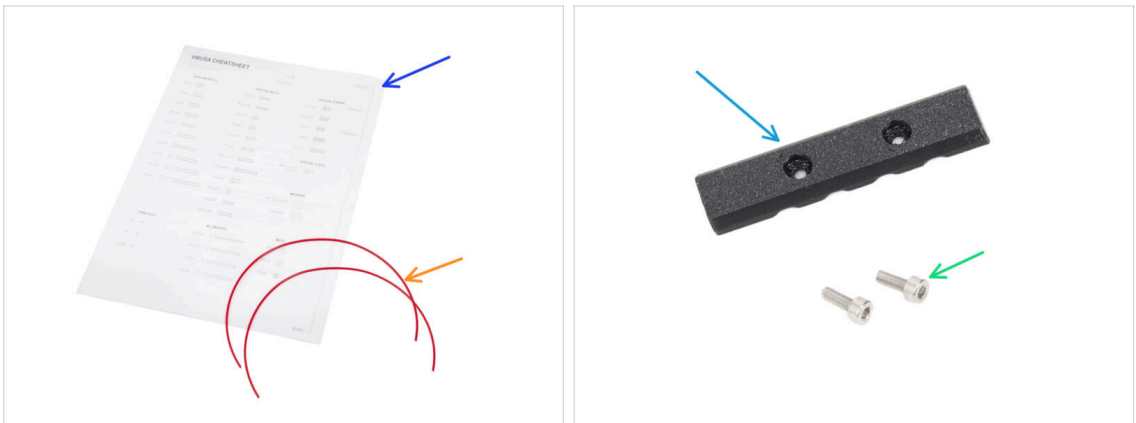

- **For the following parts, please prepare:**
- Prusa Cheatsheet (1x)
 - ⓘ It is on the reverse side of the welcome letter you received at the beginning of the package.
- Filament 300 mm (2x)
 - ✂ Cut two pieces of filament at least 300 mm long. We recommend using PETG, but it's not required.
 - ⓘ If you have a 300 mm gauge, you can use it as an alternative.
- INDX-PTFE-holder-cover (1x) *found in the Filament holder left bag*
- M3x10 screw (2x) *you removed earlier*

PASSO 57 Attaching the PTFE tubes - left



- ◆ Insert two M3x10 screws through the INDX-PTFE-holder-cover and keep the part nearby.
- ◆ Guide all four PTFE tubes through the channels in the PTFE-holder. Hold them in place by hand to prevent them from falling out.
 - ⚠ **Make sure the filament sensor cables are routed in the lower channels.**
- ◆ Place the PTFE-holder-cover over the PTFE tubes and the cables. The part is not symmetrical, install it with the longer side facing down.
 - ◆ **Do not fully tighten it;** the PTFE tubes must be able to move back and forth.

PASSO 58 Measurement info



✂ In the following steps, you will measure the correct PTFE tube length between the PTFE-holder and the filament sensor. You can use a measuring tape or the filament method described below.

- ◆ Along the side of the Prusa Cheatsheet, note the scale in millimeters - these indicate the required PTFE tube lengths.
- ◆ The initial length is 300 mm. **Do not shorten it yet.**
- ⓘ In the following steps, you will be instructed to shorten the filament to the required length.
- ◆ Keep the second piece of filament for the right side.

PASSO 59 Inserting the PTFE tubes (position 1,2)



- ◆ Place one end of the filament at the filament sensor against the PTFE tube at **position 1**.
- ◆ Place the other end against the same PTFE tube at the PTFE-holder.
- ◆ Slide the filament in the PTFE-holder to match the PTFE tube length.
- 📌 Cut the filament to **270 mm**.
- ◆ Adjust the PTFE tube to **position 2** according to the shortened filament.
- ◆ Fully tighten the upper screw.
- ⓘ This will lock the first PTFE tubes in place and prevent movement.

PASSO 60 Inserting the PTFE tubes (position 3,4)



- 📌 Cut the filament to **240 mm**.
- ◆ Adjust the PTFE tube to **position 3** according to the shortened filament.
- 📌 Cut the filament to **210 mm**.
- ◆ Adjust the PTFE tube to **position 4** according to the shortened filament.
- ◆ Fully tighten the lower screw.

PASSO 61 PTFE tubes - right side: parts preparation

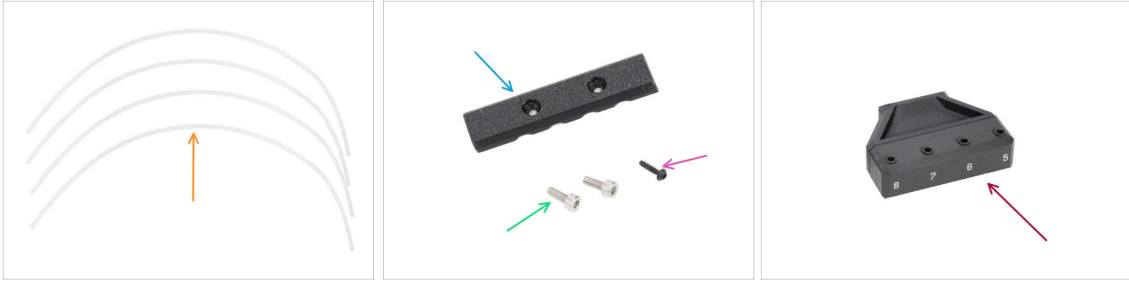

● **Per i seguenti passi prepara:**

- PTFE tube 4 x 2.5 x 880 (4x) *found in the main box*
- INDX-PTFE-holder-cover (1x) *found in the Filament holder left bag*
- 3x12sT screw (2x) *found in the Fasteners 1/2 bag*
- Vite M3x10 (2x) *rimossa in precedenza*
- Right side filament sensor (1x) *scale 8-5*

PASSO 62 Preparing the filament sensor - right



- Remove the upper center nylon rivet from the left transparent side panel.
- Insert a 3x12sT screw from the inside into the rivet hole.
- Take the filament sensor assembly with the one connector (positions 8-5) and connect the filament sensor cable to it.
- Guide the cables out through the cable channels on the left side.

PASSO 63 Mounting the filament sensor - right

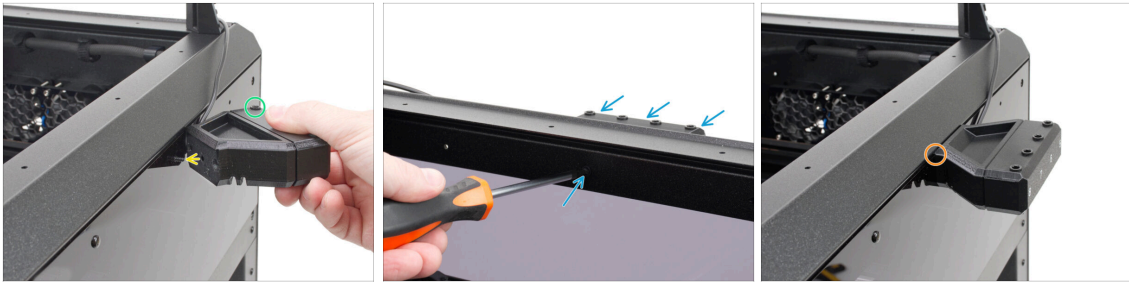

- Align the right filament sensor assembly with the protruding 3x12sT screw.
- Ensure correct orientation - the collets must face upward.
- Fully tighten the screw to secure the assembly. **Make sure that:**
 - The tab along the top edge is seated in the gap above the transparent side panel.

PASSO 64 Connecting the PTFE tube - right



- Insert the filament sensor cable into the lower cable channel in the PTFE-holder.
 - Let the excess cable hang freely at the back of the printer.
- Insert four PTFE tubes into the collects in the filament sensor.
 - Gently pull the tube to verify it is locked in the collet.

PASSO 65 Attaching the PTFE tubes - left

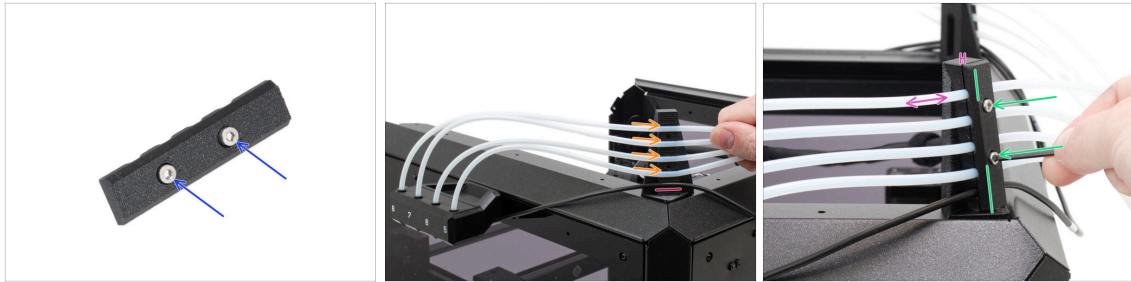

- ◆ Insert two M3x10 screws through the INDX-PTFE-holder-cover and keep the part nearby.
- ◆ Guide all four PTFE tubes through the channels in the PTFE-holder. Hold them in place by hand to prevent them from falling out.
- ⚠ **Make sure the filament sensor cable is routed in the lower channel.**
- ◆ Place the PTFE-holder-cover over the PTFE tubes and the cables. The part is not symmetrical, install it with the longer side facing down.
- ◆ **Do not fully tighten it;** the PTFE tubes must be able to move back and forth.

PASSO 66 Inserting the PTFE tubes (position 5,6)



- ◆ Prepare the Prusa Cheatsheet and the second 300-mm filament.
- ◆ Place one end of the filament at the filament sensor against the PTFE tube at **position 5**.
- ◆ Place the other end against the same PTFE tube at the PTFE-holder.
- ◆ Slide the filament in the PTFE-holder to match the PTFE tube length.
- 📌 Cut the filament to **270 mm**.
- ◆ Adjust the PTFE tube to **position 6** according to the shortened filament.
- ◆ Fully tighten the upper screw.
- ⓘ This will lock the first PTFE tubes in place and prevent movement.

PASSO 67 Inserting the PTFE tubes (position 7,8)

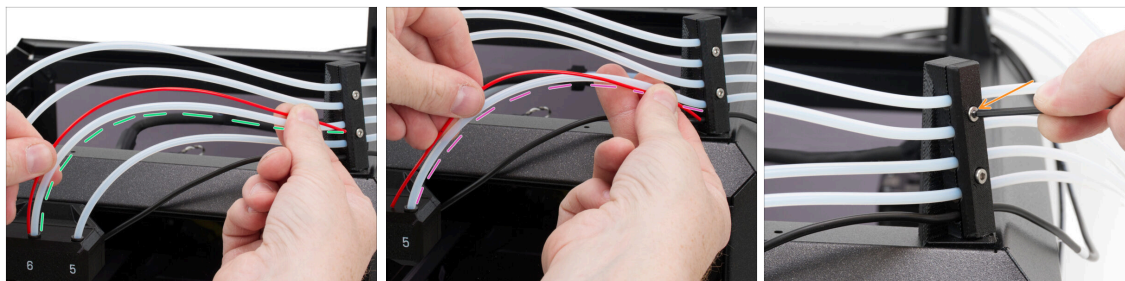

Cut the filament to **240 mm**.

● Adjust the PTFE tube to **position 7** according to the shortened filament.



Cut the filament to **210 mm**.

● Adjust the PTFE tube to **position 8** according to the shortened filament.

● Fully tighten the lower screw.

PASSO 68 Connecting the filament sensor cable

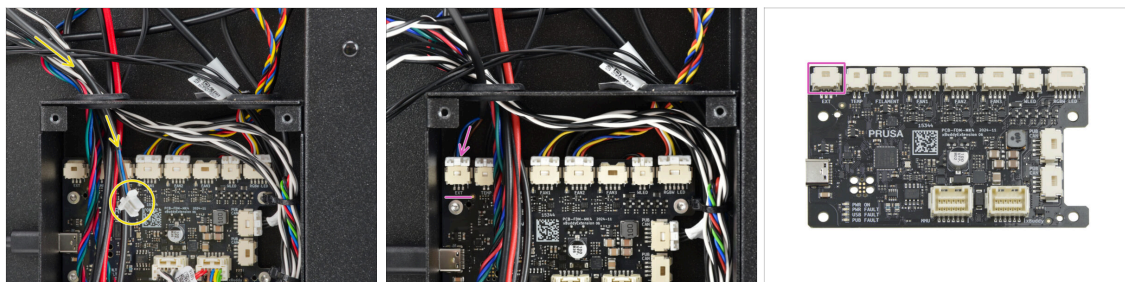

● Route the remaining loose end of the filament sensor cable through the left opening in the xBuddy box.

● Plug the filament sensor cable into the first slot labeled **EXT** on the xBuddy Extension board.

PASSO 69 È l'ora delle Haribo!

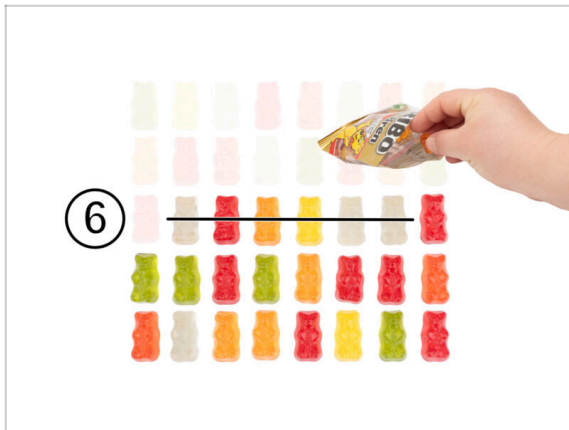

- Great job so far! Another dose of sugar is required.
- Mangia sei orsetti gommosi.

PASSO 70 Fatto



- **Congratulations!** You have just assembled the INDX Toolhead and the side filament sensors.
- Andiamo al prossimo capitolo.

5. Spool holders & Tool dock assembly



PASSO 1 Attrezzi necessari per questo capitolo

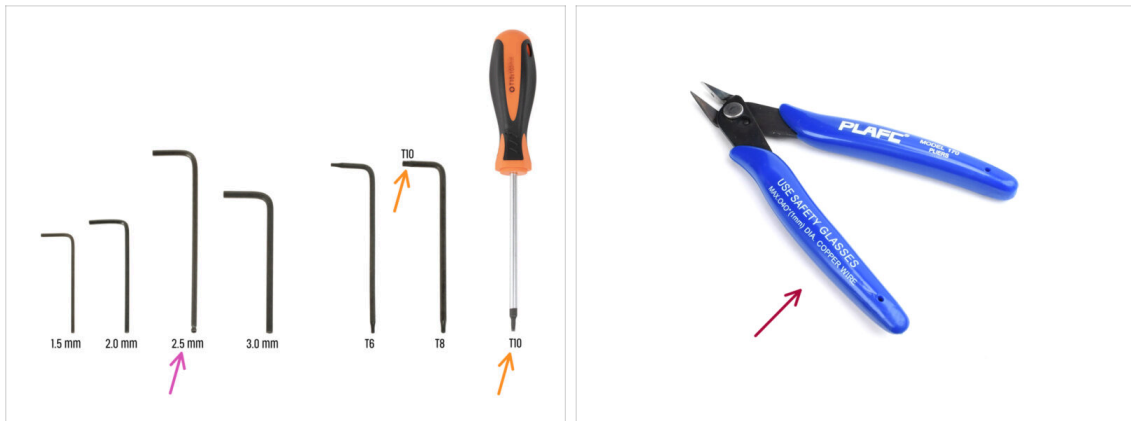

Per questo capitolo prepara:

- Chiave a brugola da 2.5mm
- T10 key / screwdriver
- Flush cutters - an optional tool, recommended to use for cutting the zip ties. It can be purchased from our e-shop prusa3d.com.

PASSO 2 Side handle: parts preparation

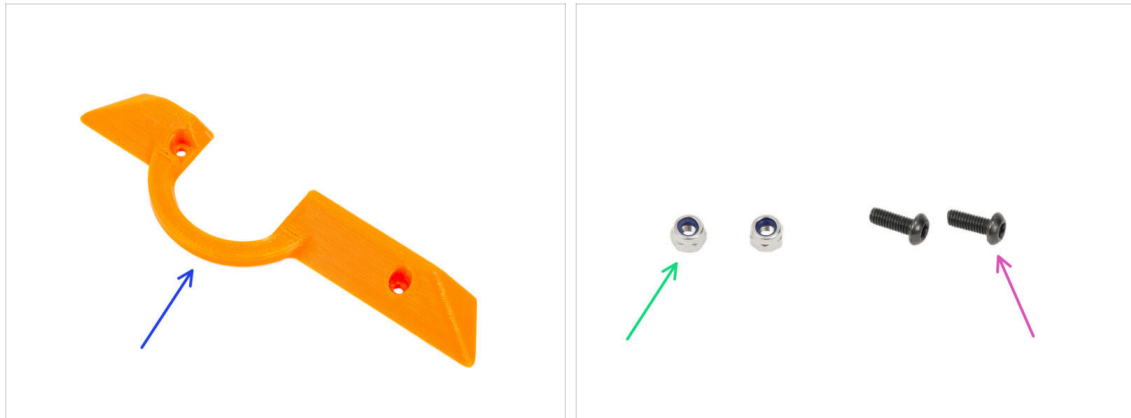

Per i seguenti passi prepara:

- INDX-C1-Side-handle-right (1x)
- M3nN nut (2x) found in the Fasteners 1/2 bag
- M3x8T screw (2x) found in the Fasteners 2/2 bag

PASSO 3 Installing the side handle



- ◆ Insert two M3x8rT screw into the Side-handle-right.
- ◆ Align the Side-handle-right with the holes in the right side panel and place it in position.
- ◆ From inside the printer, place M3nN nuts onto the screws and hold them with the universal tool.
- ◆ Firmly tighten the screws from the outside.

PASSO 4 Dock fan cable: parts preparation

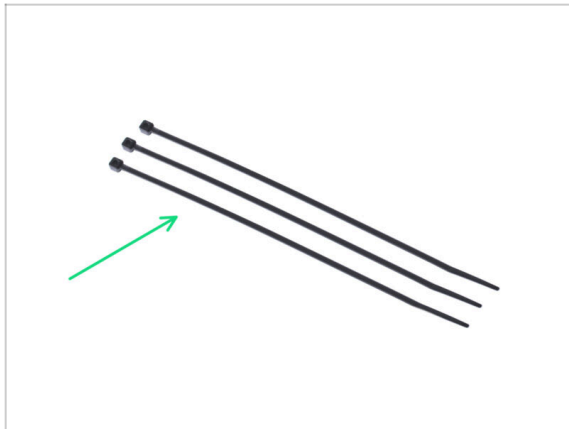

- ◆ Per i seguenti passaggi prepara:
- ◆ Fascetta (3x)

PASSO 5 Dock fan head cable



- ⓘ We recommend removing the Bowden-guide to make the zip tie insertion easier.
- 🟡 Remove the M3x10 screw that secures the Bowden-guide part.
- 🟢 Rimuovi la guida Bowden.
- 🟠 Locate the three pairs of holes on the right side of the printer. We will attach the zip ties through these.
- 🟢 Bend the end of each zip tie as shown in the picture.

PASSO 6 Securing the zip ties I.



- 🔴 Do not push the zip tie through the inner hole!
- 🟢 Ensure that the zip tie goes in **above** the smooth rod.
- 🟡 Thread each zip tie through the **outer** hole.
- 🟡 Bend the zip tie in the opposite direction.
- 🟢 Insert the zip tie into the inner hole as shown in the photo. Do not loop the zip tie around the belts.
- ⚠️ **Make sure that the zip tie is NOT looped around the belts!**

PASSO 7 Securing the zip ties II.

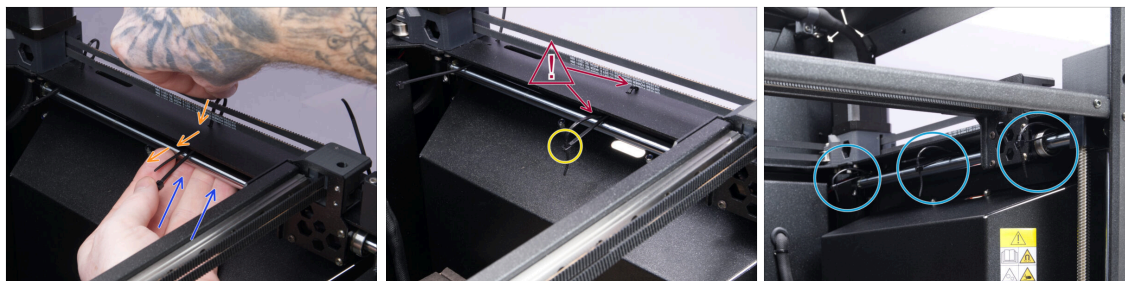

- Use your fingers from below to guide the zip tie out **above the smooth rod**.
- Push the zip tie into the inner hole. **Ensure that the zip tie is behind the belts**, not looped around them!
- ⚠ Check again that the **zip tie is not looped around the belts or the smooth rod**.
- Connect the zip tie.
- Secure all three zip ties in the same way.

PASSO 8 Attaching the dock fan cable



- ⓘ The dock fan cable connector is the remaining part of the head cable.
- Insert the Dock fan cable connector through the lower oval opening on the left side of the rear panel.
- Push the cable inside.
- Inside the printer, gently pull the dock fan cable as shown in the photo.

PASSO 9 Leading the dock fan cable I.

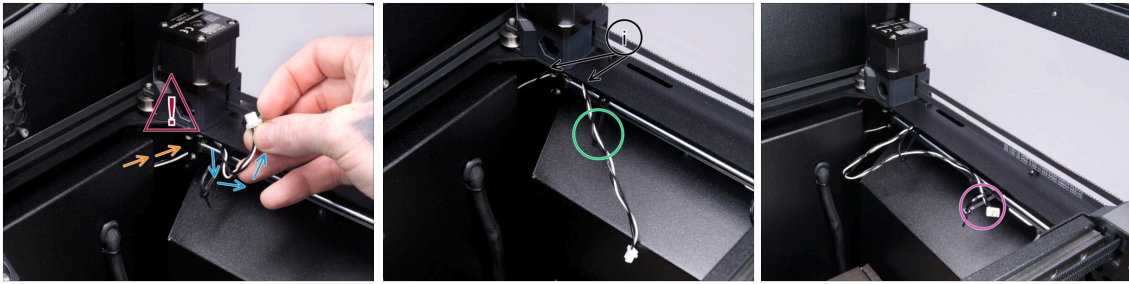

- Lead the dock fan cable **behind the rod holder**.
- ⚠ **The dock fan cable has to be led behind the rod holder! Pay extra attention to ensure that the cable is threaded around the rod holder exactly as shown in the photos.**
- Lead the cable out from behind the rod holder. The cable must come out **above the smooth rod**.
- Lead the dock fan cable through the back zip tie.
- ⓘ Check again that the cable is led correctly behind the rod holder and above the smooth rod.
- Lead the dock fan cable through the middle zip tie.

PASSO 10 Leading the dock fan cable II.

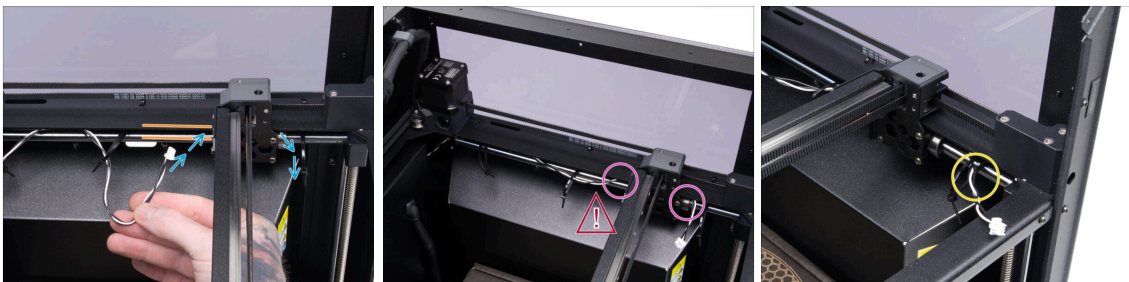

- Insert the dock fan cable and lead it behind the linear holder.
- The cable has to be inserted between the smooth rod and the printer's profile.
- ⚠ **Ensure the cable does not wrap around the smooth rod and that it is inserted **above the smooth rod**.**
- Pull the cable out on the other side above the smooth rod, as shown in the photo.
- Thread the cable through the front zip tie.

PASSO 11 Securing the dock fan cable

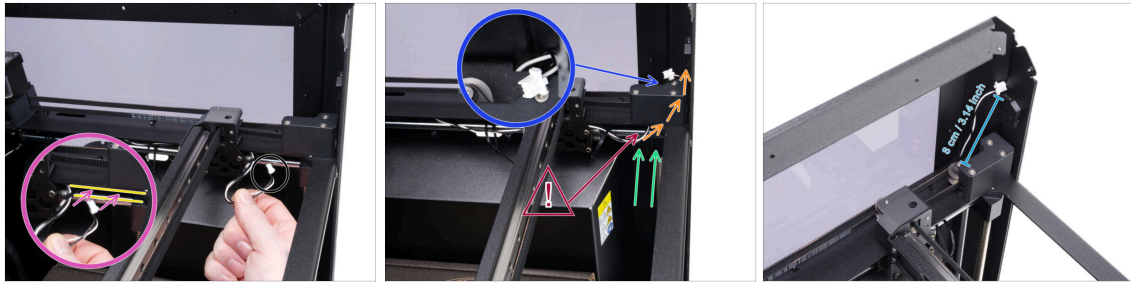

- Gently bend the dock fan cable near the connector.
- Insert the cable between the side profile and the smooth rod.
 - The cable must be inserted above the smooth rod. Ensure it is not led under or around the smooth rod.
- Lead the dock fan cable through the opening between the core XY and the printer's frame.
- Use your finger to help you guide the cable from below through the opening in the corner.
- ⚠ Double-check that the **cable is threaded correctly** above the smooth rod and under the printer's side profile.
- Carefully pull the cable out and leave it protruding for 8 cm/3.14 inches.

PASSO 12 Tightening the zip ties I.

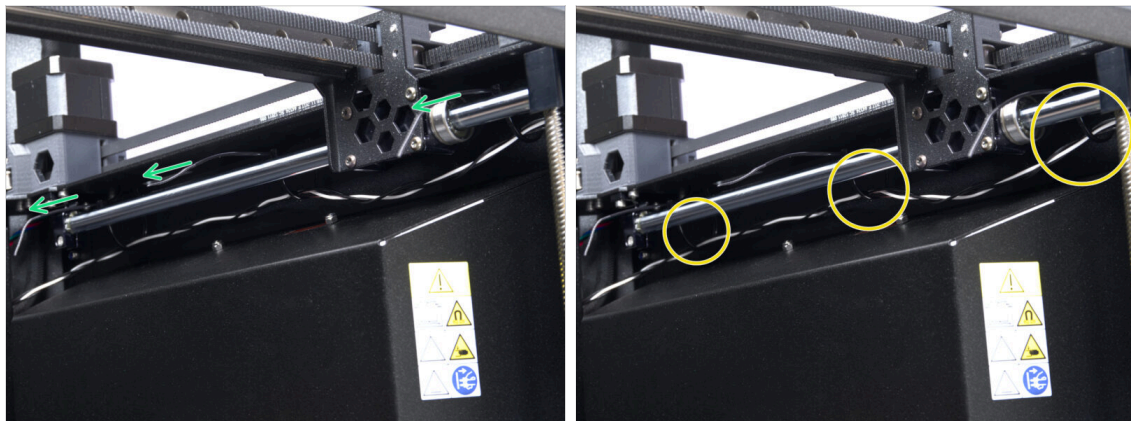

- Pull on the zip tie to tighten it so the head and pawl move inward between the profile and the smooth rod.
- Ensure one last time that the cable is threaded through all three zipties and that it is positioned exactly as shown in the photo

PASSO 13 Tightening the zip ties II.



- ① Tightening the zip ties is tricky and requires needle-nose pliers. Be very careful not to damage the printer or the cable.
- ② Before tightening the zipties, ensure that the dock fan cable is in position and protruding 8 cm/3.14 inches.
- ③ Use needle-nose pliers to carefully grab the zip tie on top and pull it up, so it can be properly tightened in the next step.
- ④ While pulling on the zip tie, use your fingers to push it upwards from below.
- ⑤ Keep pushing on the zip tie from below and start tightening it.
- ⑥ Very carefully insert the pliers and squeeze the head of the zip tie. Firmly pull on the zip tie to tighten it completely.
- ⑦ Tighten the remaining zip ties using the same process.
Cut off the excess zip ties. Ensure they are fully tightened and that the zip ties do not prevent movement of the Y axis.

PASSO 14 Nozzle cleaner: parts preparation I.

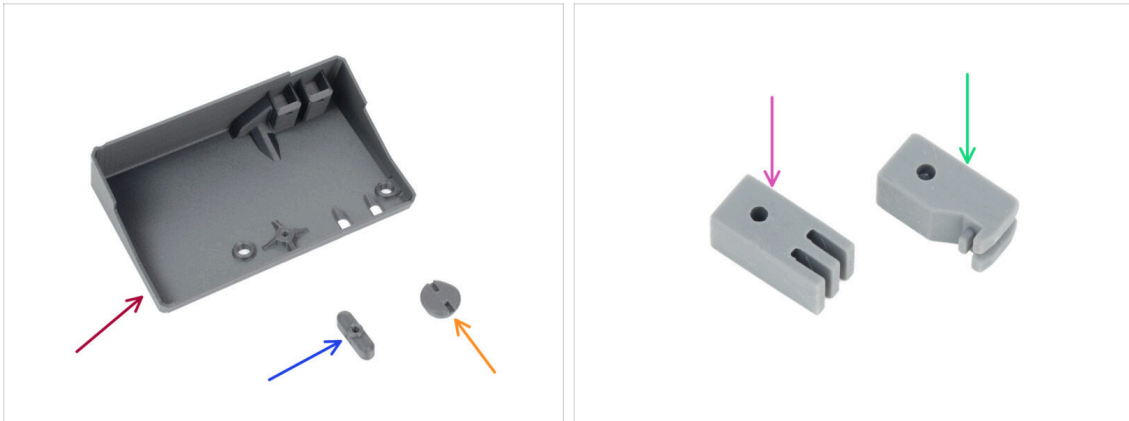

● **Per i seguenti passi prepara:**

- INDX-C1-Wiper-base (1x) *found in the Wiper bag*
 - INDX-C1-Wiper-lock (1x) *found in the Wiper bag*
 - INDX-C1-Wiper-adjuster (1x) *found in the Wiper bag*
 - Silicone wiper (1x) *found in the Fasteners 2/2 bag*
 - Silicone priming block (1x) *found in the Fasteners 2/2 bag*
- ⓘ **Nozzle cleaner** is the name for the whole assembly.

PASSO 15 Nozzle cleaner: parts preparation II.

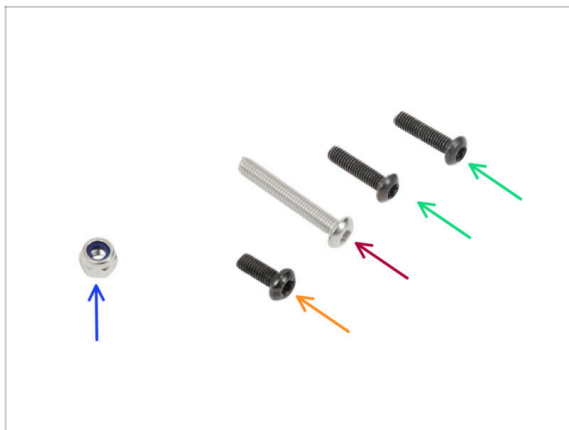

- M3N nut (1x) *found in the Fasteners 1/2 bag*
- M3x8rT screw (1x) *found in the Fasteners 2/2 bag*
- M3x20rT screw (1x) *found in the Fasteners 2/2 bag*
- M3x12rT screw (2x) *found in the Fasteners 2/2 bag*

PASSO 16 Assemblaggio del Wiper-lock



- Push the M3x20rT screw through the Wiper-lock.
- Insert the Wiper-lock with the screw into the Wiper-base.

PASSO 17 Securing the Wiper-lock



- From the opposite side, place the M3nN nut onto the screw and tighten it using the universal wrench.
- Loosen it by a quarter to half a turn so the Wiper-lock can move.
- Set the Wiper-lock **according to the markings** on the Wiper-base.
- i** If the Wiper-lock moves on its own, slightly tighten the screw.

PASSO 18 Installare il Wiper-adjuster (Supporto Raschietto)

- ◆ Insert the M3x8rT screw through the channel in the Wiper-base.
- ◆ Align the hole in the Wipe-adjuster with the screw.
- ◆ Secure the Wiper-adjuster in the slots using the universal wrench and tighten the M3x8rT screw with a T10 screwdriver.
- ◆ Note the irregular shape of the Wiper-adjuster. Use the universal wrench to position it so that its **flattened side faces downward**.

PASSO 19 Inserting the wiper blocks

- ◆ Insert the silicone priming block into the front slot (left in the photo). Ensure the part is oriented correctly.
- ◆ Insert the silicone wiper into the rear slot (right in the photo).
- ◆ Check the correct position of the silicone wiper. The wiper is sloped; make sure that the sloped side points inside the Wiper-base.
- ⓘ *Pro tip:* Lightly wipe the wiper blocks with IPA (Isopropyl alcohol) before inserting and securing them in the wiper base. This will make the insertion a lot easier.
- ◆ Secure the silicone wiper and priming block with two M3x12rT screws.
 - ◆ Guide the T10 key or screwdriver through the dedicated openings in the Wiper-base for better access.
- ⚠ **Double-check that the wiper is inserted correctly, with the sloped side pointing inside the Wiper-base.**

PASSO 20 Installing the nozzle cleaner

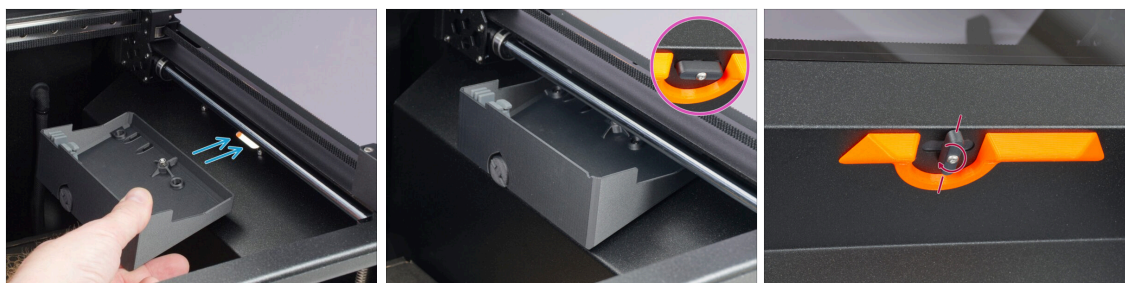

- ◆ From inside the printer, place the nozzle cleaner assembly on the right side panel.
- ◆ The Wiper-lock must fit **into the oval opening**.
- ◆ From the outside, check that the Wiper-lock extends into the handle area.
- ◆ Rotate the Wiper-lock by 90° to secure the wiper assembly in place.

PASSO 21 Electronics covers: parts preparation

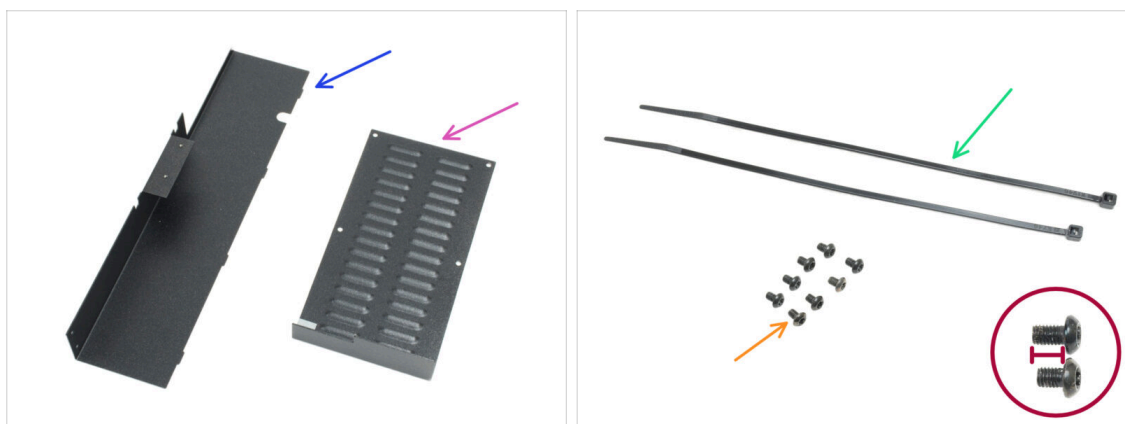

◆ **Per i seguenti passi prepara:**

- ◆ Sheet metal back cover (1x)
- ◆ Copertura xBuddy (1x)
- ◆ Zip tie (2x)
- ◆ M3x4rT screw (8x) *you removed earlier*

⚠ **Be careful not to mix up the M3x4rT and M3x5rT screws, which you will need later for the door assembly.**

PASSO 22 Securing the cables

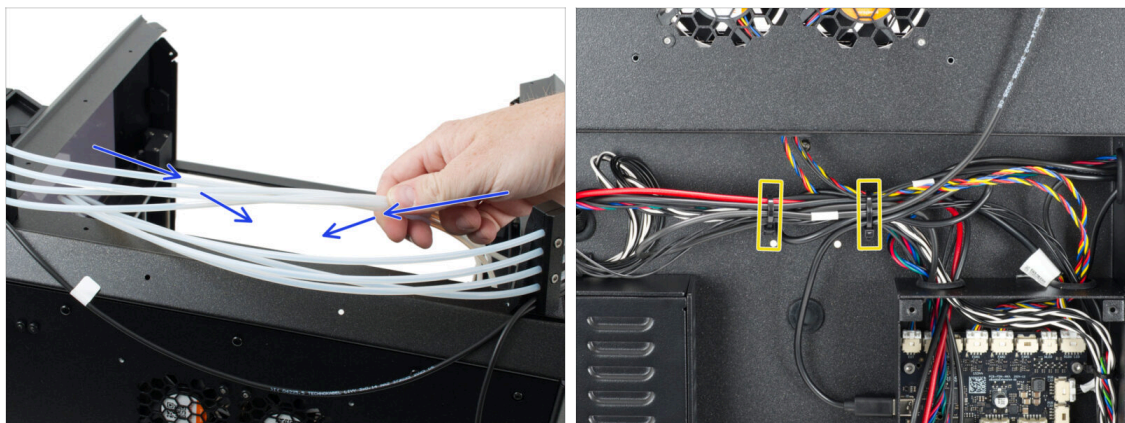

- ◆ Insert all loose ends of the PTFE tubes inside the printer.
- ◆ Form loops from the excess cables as shown in the picture.
- ◆ Bundle the cables together and secure them with two zip ties.

PASSO 23 Wiring check

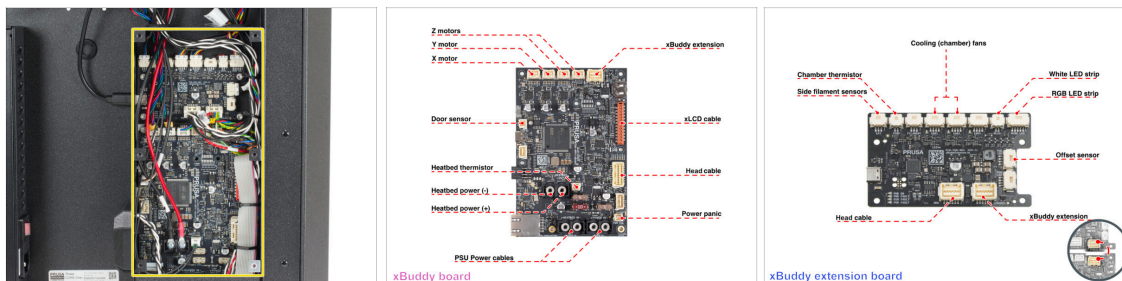

- ◆ Before closing the electronics cover, check that everything is correctly connected.
- ◆ Usa le immagini come riferimento per controllare i collegamenti dei tuoi dispositivi elettronici.
- ◆ **The electronics compartment is divided into two boards:**
 - ◆ Scheda xBuddy
 - ◆ Scheda di estensione xBuddy

PASSO 24 Coprire la scatola di xBuddy



- Coprire con cura la scatola xBuddy facendo scorrere la parte piegata del coperchio all'interno della scatola.
- ⚠ **Avoid pinching the cables and make sure to insert the cover perpendicular to the xBuddyboard.**
- Fissa la copertura della scatola xBuddy con le sei viti M3x4rT.

PASSO 25 Installare la copertura posteriore



- Align the rear sheet metal cover so that the cables can run through the "tray".
- Inserisci la piastra di copertura posteriore nell'incavo. Spingilo verso la stampante e poi spostalo verso l'alto per agganciarlo.
- Ci sono quattro linguette che dovrebbero agganciarsi al telaio della stampante.
- Insert the filament sensor cable to the cutout.
- If you have a USB-C cable for the Buddy3D camera installed, route it through the lower cutout.
- Fissa la copertura posteriore in posizione utilizzando due viti M3x4rT dall'interno della stampante.

PASSO 26 Bottom puck holders: parts preparation

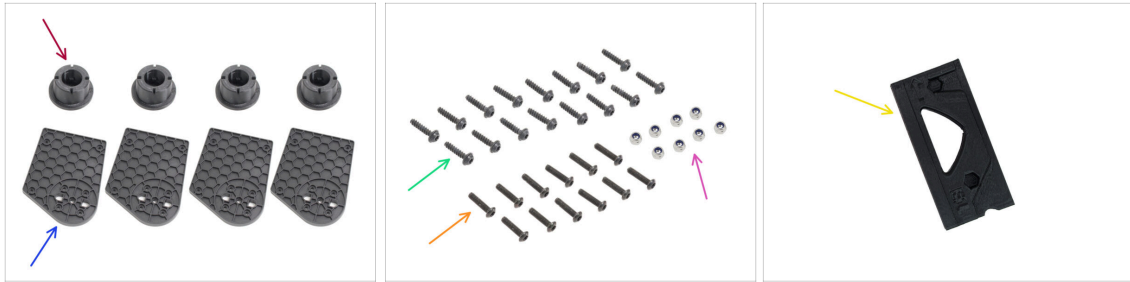

Per i seguenti passi prepara:

- Puck-universal (4x) *found in the Pucks bag*
- Puck holder bottom (4x) *found in the Puck Holders bag*
- 3x12sT screw (16x) *found in the Fasteners 2/2 bag*
- M3x12rT screw (12x) *found in the Fasteners 2/2 bag*
- M3nN nut (8x) *found in the Fasteners 1/2 bag*
- Spoolholder-assembly-tool (1x) *found in the Position Tools INDX bag*

PASSO 27 Assembling the bottom puck holders



- Align the Puck holder bottom with the holes in the Puck-universal part.
- Join the parts using four 3x12sT screws.
- Install another Puck holder bottom onto the next Puck-universal part, but in a **mirrored orientation**.
- Assemble the **second pair** of the Puck holder bottom parts using the same procedure.

PASSO 28 Removing the screws - right

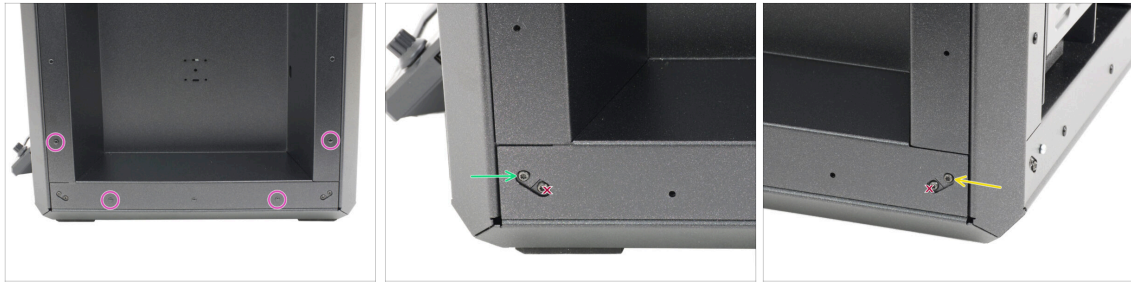

- ◆ On the right side of the printer, remove the two marked nylon rivets from each lower corner.
- ◆ Remove the **upper** M3x4rT screw from the lower left corner of the side panel.
- ◆ Remove the **upper** M3x4rT screw from the lower right corner of the side panel.

PASSO 29 Mounting the bottom puck holders - right



- ◆ Place one Puck holder bottom in the rear corner on the right side. Ensure that the orientation is correct.
- ◆ Secure it with the M3x12rT screw.
- ◆ Place one Puck holder bottom in the front corner on the right side. Ensure that the orientation is correct.
- ◆ Secure it with the M3x12rT screw.

PASSO 30 Securing the front Puck-holder bottom - right I.



- We use an orange Spoolholder-assembly-tool in this guide for clarity. Your tool is black.
- Insert one M3nN nut into the Spoolholder-assembly-tool as shown in the photo.
- ⓘ **The side of the nut without the rubber must point outward from the Spoolholder-assembly-tool.**
- Double-check that the nut is inserted in the same hole closer to the top edge, with the **arrow pointing RIGHT next to it.**
- Insert the Spoolholder-assembly-tool **into the printer**, with the M3nN nut facing the side cover.
- ⚠ **Note the orientation of the Spoolholder-assembly-tool in the photo, where it is inserted into the printer.**
- "Hook" the ridge in the assembly tool onto the side of the metal profile.
- The M3nN nut is now in the right position and height for the puck holder bottom to be attached to the printer with the M3x12rT screw.

PASSO 31 Securing the front Puck-holder bottom - right II.



- Hold the Spoolholder-assembly-tool in position with your hand on the inside of the printer.
- Use the Torx key to tighten the M3x12rT screw.
- The front right puck holder is now attached to the printer.

PASSO 32 Securing the rear Puck-holder bottom - right I.



- Insert one M3nN nut into the Spoolholder-assembly-tool as shown in the photo.
- ⓘ **The side of the nut without the rubber must point outward from the Spoolholder-assembly-tool.**
- Double-check that the nut is inserted in the same hole closer to the top edge, with the **arrow pointing UP** next to it.
- Insert the Spoolholder-assembly-tool **into the back of the printer**, with the M3nN nut facing the side cover.
- ⚠ **Note the orientation of the Spoolholder-assembly-tool in the photo, where it is inserted into the printer.**
- "Hook" the ridge in the assembly tool onto the side of the metal profile.
- ⓘ The M3nN nut is now in the right position and height for the puck holder bottom to be attached to the printer with the M3x12rT screw.

PASSO 33 Securing the rear Puck-holder bottom - right II.



- Hold the Spoolholder-assembly-tool in position with your hand on the inside of the printer.
- Use the Torx key to tighten the M3x12rT screw.
- The rear right puck holder is now attached to the printer.

PASSO 34 Removing the screws - left

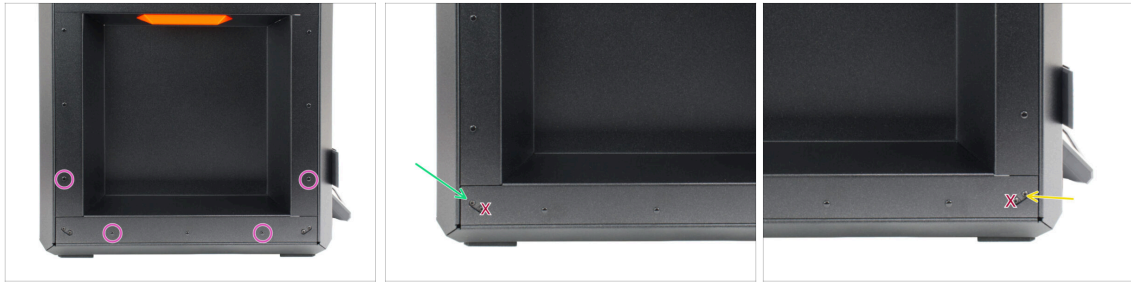

- On the left side of the printer, remove the two marked nylon rivets from each lower corner.
- Remove the **upper** M3x4rT screw from the lower left corner of the side panel.
- Remove the **upper** M3x4rT screw from the lower right corner of the side panel.

PASSO 35 Mounting the bottom puck holders - left



- Place one Puck holder bottom in the rear corner on the left side. Ensure that the orientation is correct.
- Secure it with the M3x12rT screw.
- Place one Puck holder bottom in the front corner on the left side. Ensure that the orientation is correct.
- Secure it with the M3x12rT screw.

PASSO 36 Securing the front Puck-holder bottom - left I.



- Insert one M3nN nut into the Spoolholder-assembly-tool as shown in the photo.
 - **The side of the nut without the rubber must point outward from the Spoolholder-assembly-tool.**
 - Double-check that the nut is inserted in the same hole closer to the top edge, with the **arrow pointing UP next to it.**
- Insert the Spoolholder-assembly-tool **into the printer**, with the M3nN nut facing the side cover.
- ⚠ **Note the orientation of the Spoolholder-assembly-tool in the photo, where it is inserted into the printer.**
- "Hook" the ridge in the assembly tool onto the side of the metal profile.
- ⓘ The M3nN nut is now in the right position and height for the puck holder bottom to be attached to the printer with the M3x12rT screw.

PASSO 37 Securing the front Puck-holder bottom - left II.

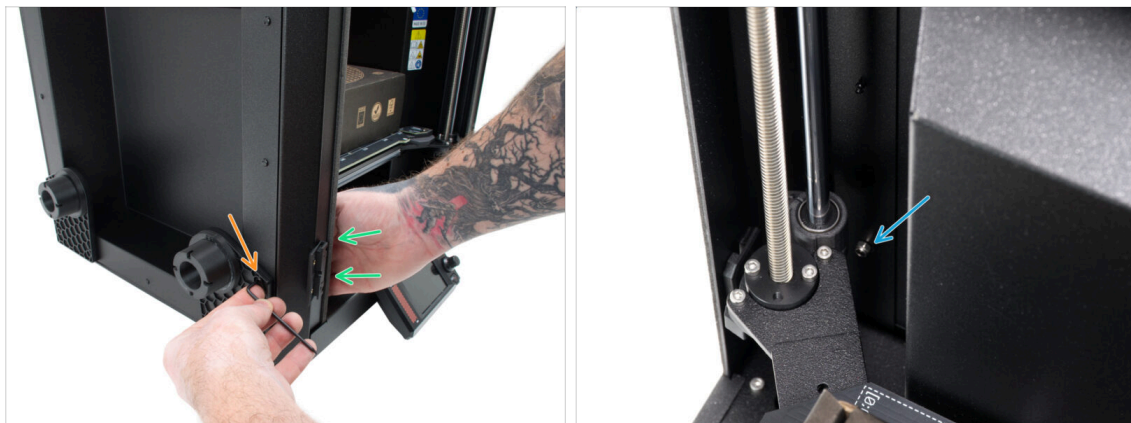

- Hold the Spoolholder-assembly-tool in position with your hand on the inside of the printer.
- Use the Torx key to tighten the M3x12rT screw.
- The front left puck holder is now attached to the printer.

PASSO 38 Securing the rear Puck-holder bottom - left I.



- Insert one M3nN nut into the Spoolholder-assembly-tool as shown in the photo.
- **The side of the nut without the rubber must point outward from the Spoolholder-assembly-tool.**
- Double-check that the nut is inserted in the same hole closer to the top edge, with the **arrow pointing RIGHT next to it.**
- Insert the Spoolholder-assembly-tool **into the printer**, with the M3nN nut facing the side cover.
- ⚠ **Note the orientation of the Spoolholder-assembly-tool in the photo, where it is inserted into the printer.**
- "Hook" the ridge in the assembly tool onto the side of the metal profile.
- ⓘ The M3nN nut is now in the right position and height for the puck holder bottom to be attached to the printer with the M3x12rT screw.

PASSO 39 Securing the rear Puck-holder bottom - left II.



- Hold the Spoolholder-assembly-tool in position with your hand on the inside of the printer.
- Use the Torx key to tighten the M3x12rT screw.
- The rear left puck holder is now attached to the printer.

PASSO 40 Tilting the printer



- i To gain access to the bottom of the printer, it has to be placed on its back. Use the Prusament box that is protecting the heatbed.
- Remove the Prusament box from the heatbed and place it behind the printer.
- Move the toolhead to the back of the printer.
- Place all the PTFE tubes inside the printer.
- Place the box behind the printer and slowly and carefully lay the printer down so it can lean on the box.
- ⚠ **Ensure that the printer is stable and that it can not slide or fall when tilted. We recommend asking someone to hold the printer while it rests on the box to ensure your safety.**
- Ensure that the filament sensor cables are not pinched.

PASSO 41 Finishing the rear puck holder bottom - left I.



- Insert one M3nN nut into the Spoolholder-assembly-tool as shown in the photo.
- **The side of the nut without the rubber must point outward from the Spoolholder-assembly-tool.**
- Double-check that the nut is inserted in the same hole closer to the top edge, with the **arrow pointing RIGHT** next to it.
- Use the highlighted ridge in the Spoolholder-assembly-tool to position the tool correctly against the printer profile.
- Insert the Spoolholder-assembly-tool with the M3nN nut inside the bottom of the printer, with **the nut facing the side cover.**
- Check that the Spoolholder-assembly-tool is placed correctly. The bottom profile of the printer has to align with the ridge in the tool.
- ⓘ The M3nN nut is now in the right position and height for the puck holder bottom to be attached to the printer with the M3x12rT screw.

PASSO 42 Finishing the rear puck holder bottom - left II.



- Hold the Spoolholder-assembly-tool in position with your hand on the inside of the printer.
- Use the Torx key to tighten the M3x12rT screw.
- The rear left puck holder is now completely attached to the printer.

PASSO 43 Finishing the front puck holder bottom - left I.



- Insert one M3nN nut into the Spoolholder-assembly-tool as shown in the photo.
 - i **The side of the nut without the rubber must point outward from the Spoolholder-assembly-tool.**
 - Double-check that the nut is inserted in the same hole closer to the top edge, with **the arrow pointing UP next to it.**
 - Insert the Spoolholder-assembly-tool under the front of the printer, with the M3nN nut facing the side cover.
 - "Hook" the ridge in the assembly tool onto the side of the metal profile and gently push the tool upwards.
 - i The M3nN nuts are now in the right position and height for the puck holder top to be attached to the printer with two M3x12rT screws.

PASSO 44 Finishing the front puck holder bottom - left II.



- Hold the Spoolholder-assembly-tool in position with your hand on the inside of the bottom of the printer.
 - Use the Torx key to tighten the M3x12rT screw.
 - The front left puck holder is now completely attached to the printer.

PASSO 45 Finishing the rear puck holder bottom - right I.

- ◆ Insert one M3nN nut into the Spoolholder-assembly-tool as shown in the photo.
 - ◆ **The side of the nut without the rubber must point outward from the Spoolholder-assembly-tool.**
 - ◆ Double-check that the nut is inserted in the same hole closer to the top edge, with the **arrow pointing UP next to it.**
- ◆ Insert the Spoolholder-assembly-tool under the front of the printer, with the M3nN nut facing the side cover.
- ◆ "Hook" the ridge in the assembly tool onto the side of the metal profile and gently push the tool upwards.
- ⓘ The M3nN nuts are now in the right position and height for the puck holder top to be attached to the printer with two M3x12rT screws.

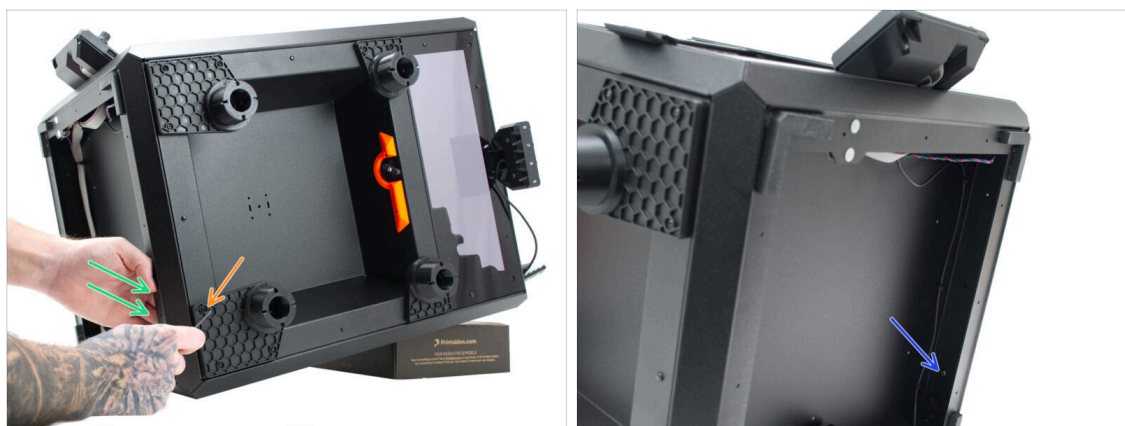
PASSO 46 Finishing the rear puck holder bottom - right II.

- ◆ Hold the Spoolholder-assembly-tool in position with your hand on the inside of the bottom of the printer.
- ◆ Use the Torx key to tighten the M3x12rT screw.
- ◆ The rear right puck holder is now completely attached to the printer.

PASSO 47 Finishing the front puck holder bottom - right I.



- ◆ Insert one M3nN nut into the Spoolholder-assembly-tool as shown in the photo.
 - i **The side of the nut without the rubber must point outward from the Spoolholder-assembly-tool.**
 - ◆ Double-check that the nut is inserted in the same hole closer to the top edge, with the **arrow pointing RIGHT next to it.**
 - ◆ Insert the Spoolholder-assembly-tool under the front of the printer, with the M3nN nut facing the side cover.
 - ⚠ **Note the orientation of the Spoolholder-assembly-tool in the photo, where it is inserted into the printer.**
 - ◆ "Hook" the ridge in the assembly tool onto the side of the metal profile and gently push the tool upwards.
 - i The M3nN nuts are now in the right position and height for the puck holder top to be attached to the printer with two M3x12rT screws.

PASSO 48 Finishing the front puck holder bottom - right II.



- ◆ Hold the Spoolholder-assembly-tool in position with your hand on the inside of the bottom of the printer.
 - ◆ Use the Torx key to tighten the M3x12rT screw.
 - ◆ The front right puck holder is now completely attached to the printer.
 - ◆ Carefully tilt the printer back on its feet.

PASSO 49 Top puck holders: parts preparation

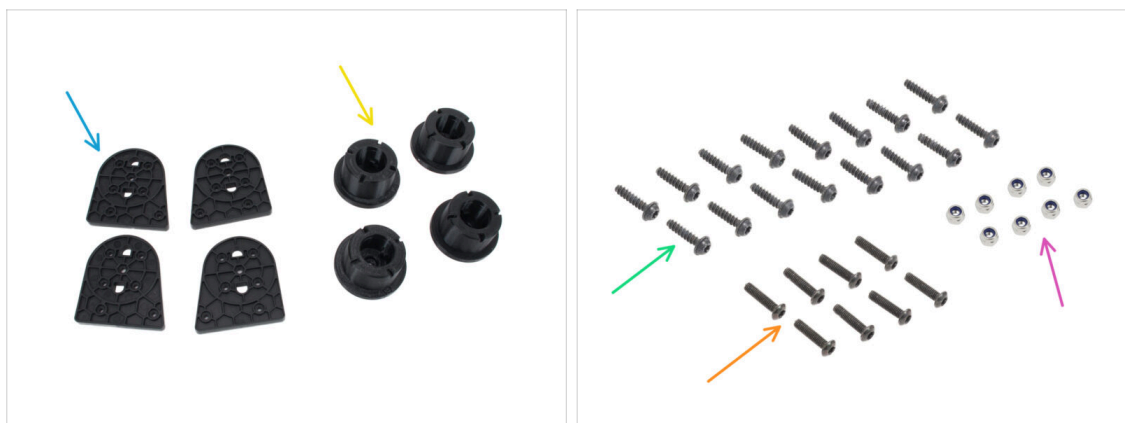

- Puck holder top (4x) found in the Puck Holders bag
- Puck-universal (4x) found in the Pucks bag
- 3x12sT screw (16x) found in the Fasteners 2/2 bag
- M3x12rT screw (8x) found in the Fasteners 2/2 bag
- M3nN nut (8x) found in the Fasteners 1/2 bag

PASSO 50 Assembling the puck holder top



- Align the Puck holder top with the holes in the Puck-universal part.
- Join the parts using four 3x12sT screws.
- Install another Puck holder top onto the next Puck-universal part, but **in a mirrored orientation**.
- Assemble the **second pair** of the Puck holder tops parts using the same procedure.

PASSO 51 Removing the nylon rivets - right

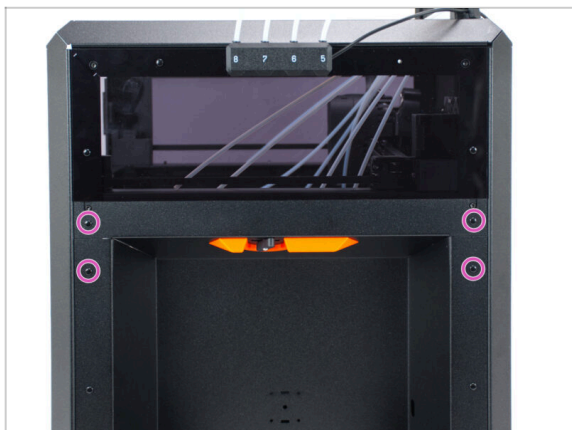

- On the right side of the printer, remove the two marked nylon rivets from each top corner.

PASSO 52 Mounting the front puck holder top - right

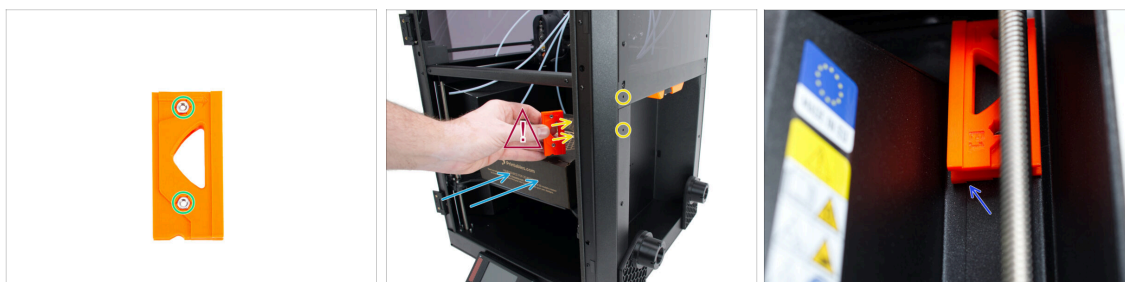

- Insert two M3nN nuts into the Spoolholder-assembly-tool as shown in the photo.
- Place the filament box back onto the heatbed.
- i** The side of the nuts without the rubber must point outward from the Spoolholder-assembly-tool.
- i** The side of the nut without the rubber must point outward from the Spoolholder-assembly-tool.
- !** Double-check that the nuts are inserted on the correct side of the tool. Note the hole closer to the top edge, with the **arrow pointing RIGHT next to it**.
- Insert the Spoolholder-assembly-tool into the printer, with the M3nN nuts facing the side cover.
- "Hook" the ridge in the assembly tool onto the side of the metal profile and gently push the tool upwards.
- i** The M3nN nuts are now in the right position and height for the puck holder top to be attached to the printer with two M3x12rT screws.

PASSO 53 Securing the front puck holder top - right



- Hold the Spoolholder-assembly-tool in position with your hand on the inside of the printer.
- Place the front puck holder top on the printer. Note the correct position in the photo.
- ⓘ Insert the M3x12rT screw into the front puck holder top before attaching it to make it easier to connect the screw with the nut. Using only one hand is a bit fiddly, but manageable.
- Use the Torx key to tighten the top M3x12rT screw.
- Use the Torx key to tighten the lower M3x12rT screw.
- The front right puck holder is now attached to the printer.

PASSO 54 Mounting the rear puck holder top - right



- Insert two M3nN nuts into the Spoolholder-assembly-tool as shown in the photo.
- ⓘ **The side of the nut without the rubber must point outward from the Spoolholder-assembly-tool.**
- Double-check that the nuts are inserted on the correct side of the tool. Note the hole closer to the top edge, with the **arrow pointing UP next to it.**
- Insert the Spoolholder-assembly-tool **into the printer**, with the M3nN nut facing the side cover.
- ⚠ **Note the orientation of the Spoolholder-assembly-tool in the photo, where it is inserted into the printer.**
- "Hook" the ridge in the assembly tool onto the side of the metal profile and gently push the tool upwards.
- ⓘ The M3nN nuts are now in the right position and height for the puck holder top to be attached to the printer with two M3x12rT screws.

PASSO 55 Securing the rear puck holder top - right



- ◆ Hold the Spoolholder-assembly-tool in position with your hand on the inside of the printer.
- ◆ Place the rear puck holder top on the printer. Note the correct position in the photos.
- 📌 Insert the M3x12rT screw into the front puck holder top before attaching it. This will make it easier to connect the screw with the nut. Using only one hand is a bit fiddly, but manageable.
- ◆ Use the Torx key to tighten the top M3x12rT screw.
- ◆ Use the Torx key to tighten the lower M3x12rT screw.
- ◆ The rear left puck holder is now attached to the printer.

PASSO 56 Removing the nylon rivets - left



- ◆ On the left side of the printer, remove the two marked nylon rivets from each top corner.

PASSO 57 Mounting the front puck holder top - left

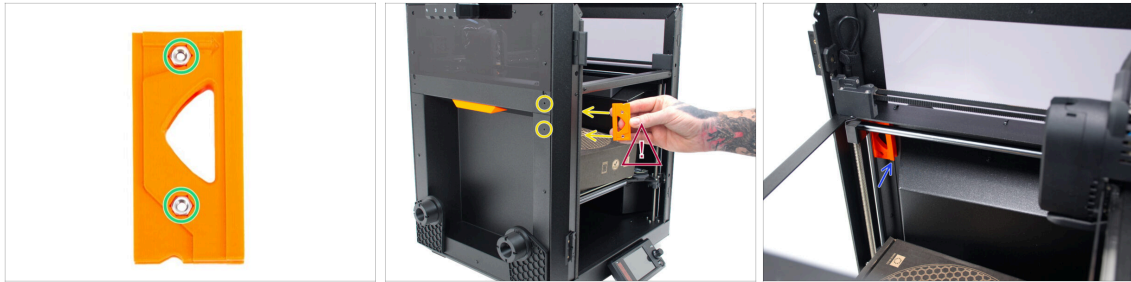

- ◆ Insert two M3nN nuts into the Spoolholder-assembly-tool as shown in the photo.
 - ◆ Double-check that the nut is inserted in the same hole closer to the top edge, with the **arrow pointing RIGHT next to it**.
- ◆ Insert the Spoolholder-assembly-tool **into the printer**, with the M3nN nuts facing the side cover.
- ⚠ **Note the orientation of the Spoolholder-assembly-tool in the photo, where it is inserted into the printer.**
- ◆ "Hook" the ridge in the assembly tool onto the side of the metal profile and gently push the tool upwards.
- ⓘ The M3nN nuts are now in the right position and height for the puck holder top to be attached to the printer with two M3x12rT screws.

PASSO 58 Securing the front puck holder top - left



- ◆ Hold the Spoolholder-assembly-tool in position with your hand on the inside of the printer.
- ◆ Place the front puck holder top on the printer. Note the correct position in the photo.
- ⓘ Insert the M3x12rT screw into the front puck holder top before attaching it to make it easier to connect the screw with the nut. Using only one hand is a bit fiddly, but manageable.
- ◆ Use the Torx key to tighten the top M3x12rT screw.
- ◆ Use the Torx key to tighten the lower M3x12rT screw.
- ◆ The front left puck holder is now attached to the printer.

PASSO 59 Mounting the rear puck holder top - left

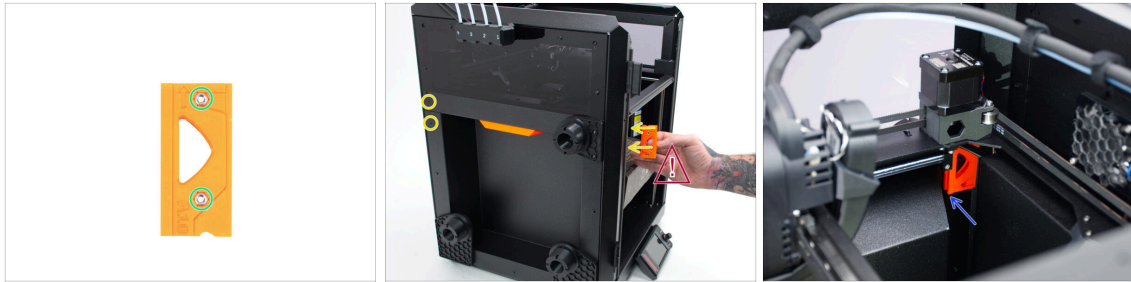

- ◆ Insert two M3nN nuts into the Spoolholder-assembly-tool as shown in the photo.
 - ◆ Double-check that the nut is inserted in the same hole closer to the top edge, with the **arrow pointing UP next to it**.
- ◆ Insert the Spoolholder-assembly-tool **into the printer**, with the M3nN nuts facing the side cover.
- ⚠ **Note the orientation of the Spoolholder-assembly-tool in the photo, where it is inserted into the printer.**
- ◆ "Hook" the ridge in the assembly tool onto the side of the metal profile and gently push the tool upwards.
- ⓘ The M3nN nuts are now in the right position and height for the puck holder top to be attached to the printer with two M3x12rT screws.

PASSO 60 Securing the rear puck holder top - left



- ◆ Hold the Spoolholder-assembly-tool in position with your hand on the inside of the printer.
- ◆ Place the front puck holder top on the printer. Note the correct position in the photo.
- ⓘ Insert the M3x12rT screw into the front puck holder top before attaching it to make it easier to connect the screw with the nut. Using only one hand is a bit fiddly, but manageable.
- ◆ Use the Torx key to tighten the top M3x12rT screw.
- ◆ Use the Torx key to tighten the lower M3x12rT screw.
- ◆ The rear left puck holder is now attached to the printer.

PASSO 61 Dock fan: parts preparation



- Per i seguenti passaggi prepara:
- Dock-fan-holder (1x) *found in the Tool Dock Fan bag*
 - Dock fan blower (1x) *found in the Tool Dock Fan bag*
 - INDX FunFan board (1x) *found in the Tool Dock Fan bag*
 - Vite M3x25 (1x)
 - Dado M3nS (1x)
 - M3x8rT screw (1x)
 - M3x35 screw (2x) *found in the Tool Dock Fan bag*

PASSO 62 Assembling the dock fan

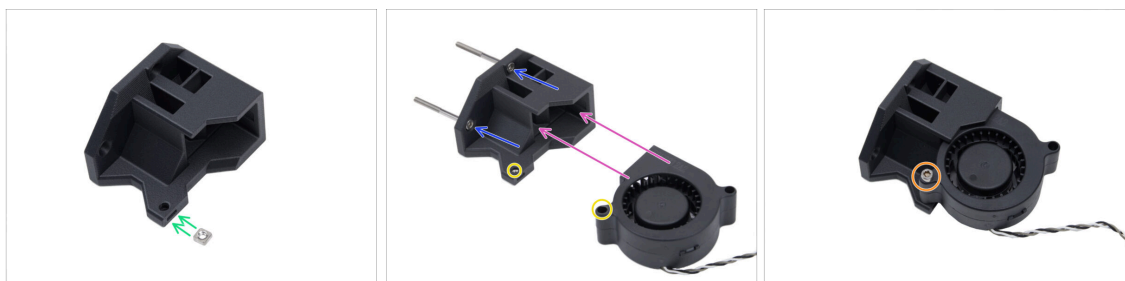

- Insert the M3nS nut into the Dock-fan-holder.
- Insert the two M3x35 screws into the Dock-fan-holder. Do this **before attaching the dock fan**.
- Insert the dock fan. Ensure that the orientation of the dock fan is as shown in the photo.
- The highlighted holes have to align once the dock fan is inserted.
- Secure the dock fan in the Dock-fan-holder with the M3x25 screw.

PASSO 63 Attaching the FunFan board

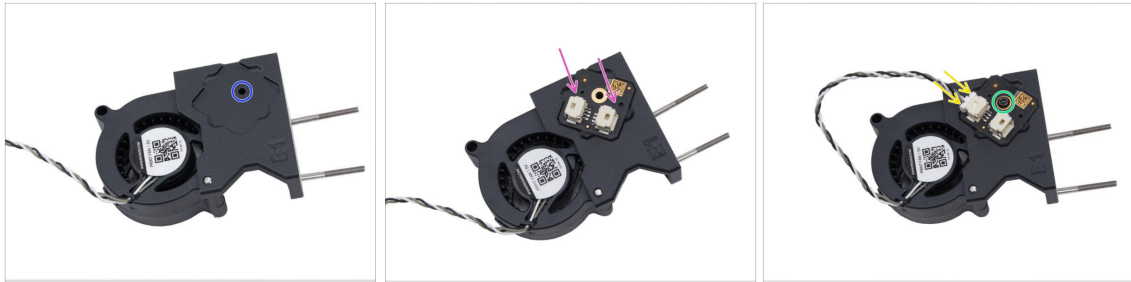

- ◆ Flip the dock fan assembly so that the sticker on the dock fan is visible.
- Note the highlighted area.
- ◆ Place the FunFan board into the ridge in the Dock-fan-holder. Ensure that the hole in the board aligns with the hole in the holder.
- ⓘ Before you touch the electronics, touch any conductive (metal) surface to neutralize the static charge from your hands.
- ◆ Maneggiando la scheda, toccane sempre solo i lati. Evita di toccare i componenti sulla superficie.
- Secure the INDX FunFan board in place with the M3x8rT screw.
- Plug the dock fan cable into the slot that is closer to the fan. Ensure that the safety latch clicks in place.

PASSO 64 Attaching the dock fan

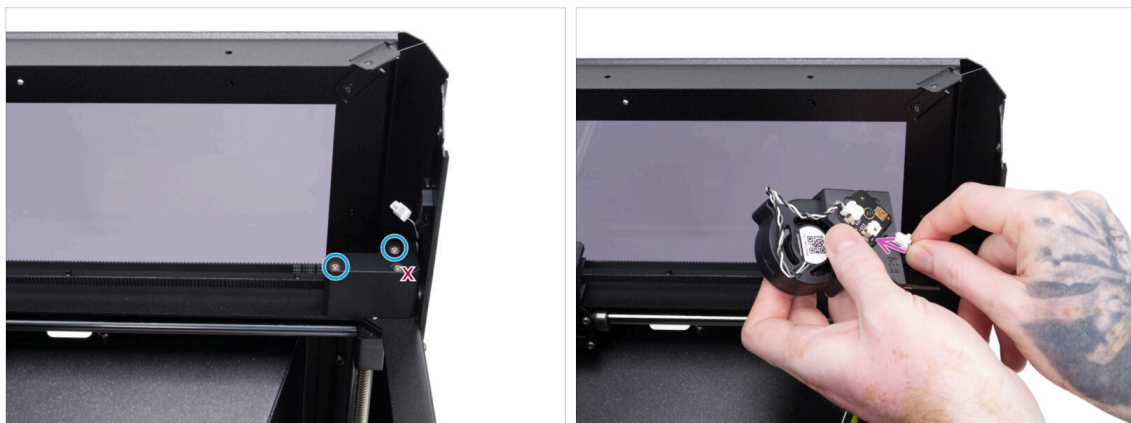

- Remove the two highlighted M3x30 screws from the Belt-tensioner.
- Do not remove the third screw.
- ◆ Plug the dock fan cable connector into the remaining slot on the FunFan board. Make sure that the safety latch clicks in place.
- ⓘ Be careful not to scratch or damage the printer with the two screws protruding from the dock fan assembly.

PASSO 65 Securing the dock fan



- With the dock fan cable plugged in, carefully turn the dock fan assembly.
- Gently lower the dock fan assembly to insert both M3x35 screws into the Belt-tensioner as shown.
- With the dock fan in place, use the 2.5mm Allen key to tighten the two M3x35 screws.

PASSO 66 È l'ora delle Haribo!

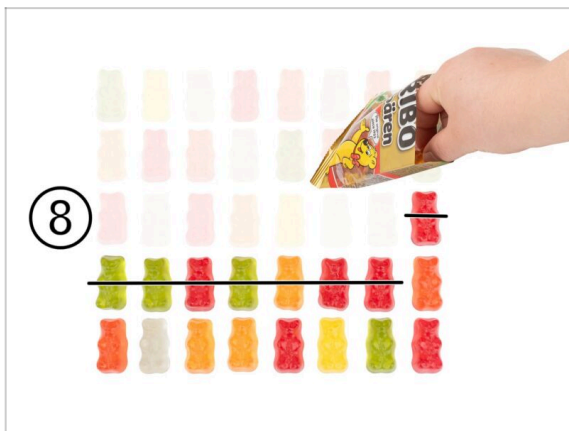

- That was a big one. Reward yourself properly and refill your energy.
- Eat 8 gummy bears.

PASSO 67 Tool holder: parts preparation

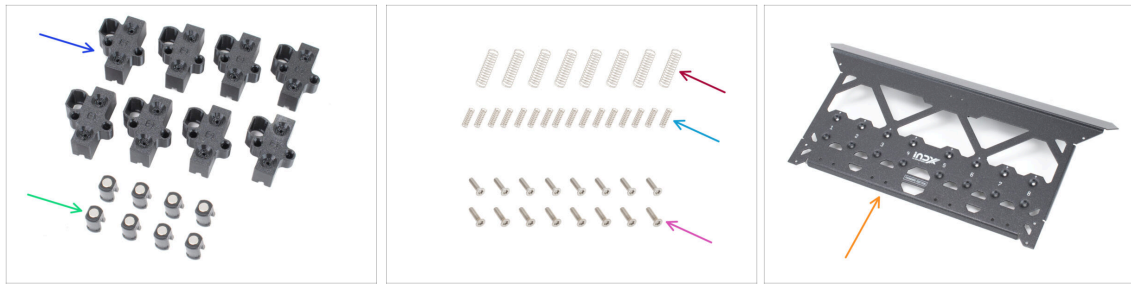

● **Per i seguenti passi prepara:**

- INDX-Tool-holder (8x) *found in the Tools bag*
- Thimble (8x) *found in Tools bag*
- Spring 0.5 x 8.5 x 30 x 15 (8x) *found in the Fasteners Tools INDX bag*
- Spring 0.63 x 5 x 15 x 11 (16x) *found in the Fasteners Tools INDX bag*
- M3x12cT countersunk screw (16x)
- INDX C1 Front profile (1x) *found in the main box*

PASSO 68 Assembling the tool holder



- Fully thread the M3x12cT screw into both holes of the Tool-holder, then remove the screw.
- **i** This creates a thread in the part, making the Tool-holder easier to install on the front profile later.
- Position the Tool-holder with the countersunk holes facing up.
- Insert each Thimble into the oval hole in part Tool-holder.
- Insert a **large spring** (0.5 x 8.5 x 30 x 15) into each Thimble.
- Insert **two small springs** (0.63 x 5 x 15 x 11) into the side holes of part Tool-holder.
- Repeat the same procedure for all remaining Tool-holder parts.

PASSO 69 Installing the tool holders



- ◆ **In the correct orientation**, place the Tool-holder against **position 1** on the underside of the front profile.
- ◆ Allinea i fori di entrambe le parti.
- ⚠ **CAUTION:** When placing the Tool-holder, make sure **no spring is pinched** against the front profile.
- ◆ Secure the Tool-holder using two M3x12cT screws.
- i The screw forms its own thread in the plastic. Slight resistance is expected.
- ◆ Grasp the Tool-holder and gently wiggle it. It **must not be rigid** - a slight, barely perceptible looseness is required.
- ⏏ **Repeat the procedure for the remaining Tool-holder assemblies** on the front profile, ideally in order 1-4, then 8-5 for easier handling.

PASSO 70 Nozzle seal holder: parts preparation

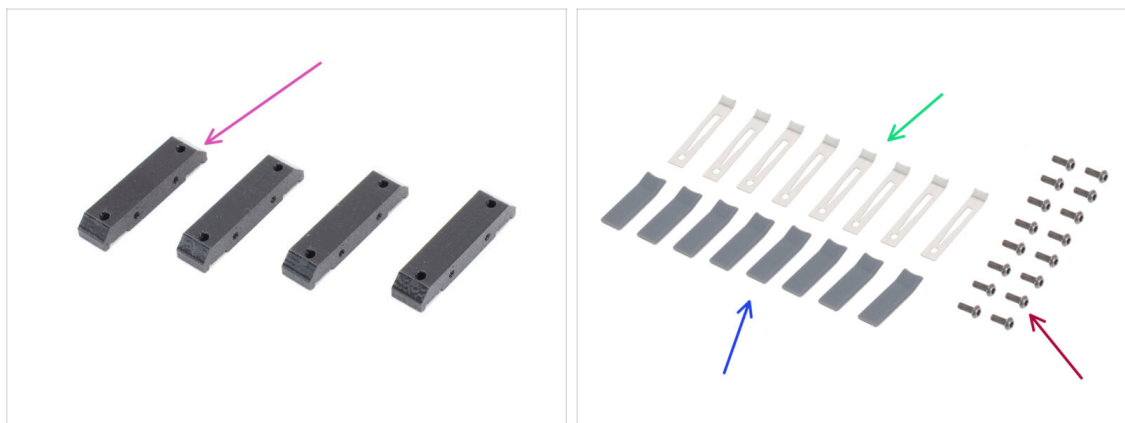

- ◆ **Per i seguenti passi prepara:**
- ◆ Nozzle-seal-holder (4x) *found in the Tools bag*
- ◆ Nozzle parking plate (8x) *found in the Fasteners Tools INDX*
- ◆ Nozzle seal (8x) *found in the Fasteners Tools INDX*
- ◆ M3x8rT screw (16x) *found in the Fasteners 2/2 bag*

PASSO 71 Assembling the nozzle seal

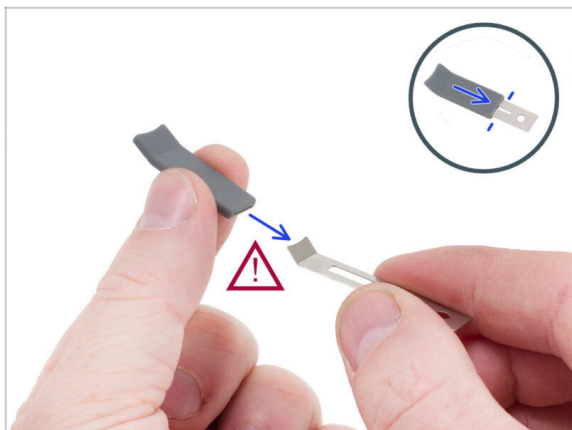

- Slide a nozzle seal (silicone sleeve) onto each nozzle parking plate.

⚠ **CAUTION:** Handle with care! The edges of the nozzle parking plate are **sharp** and may cause injury.

PASSO 72 Assembling the Nozzle-seal-holder



⚠ Note the **correct placement** of the nozzle seal before attaching it to the Nozzle-seal-holder.

- In the correct position, the nozzle seal on the opposite side **must not extend** beyond the Nozzle-seal-holder.
- Place the nozzle seal assembly onto the Nozzle-seal-holder so that the bent part of the Nozzle seal **faces upward**.
- Attach the nozzle seal assembly to the Nozzle-seal-holder using an M3x8rT screw.
- Install two nozzle seals on each Nozzle-seal-holder using the same method.
- Repeat the same procedure for the remaining assemblies.

PASSO 73 Installing the nozzle parking plates

- ◆ Align the nozzle holder assembly with the holes at positions 1–2 on the front profile.
 - ◆ Ensure the nozzle seals are **correctly oriented** by matching the bent ends to the illustration.
 - ◆ From the front, secure the nozzle seal holder assembly with two M3x8rT screws and tighten firmly.
 - ⓘ The screw forms its own thread in the plastic. Slight resistance is expected.
- ⚠ **Ensure that no nozzle parking plates are bent during the assembly.**
- ◆ Continue installing the remaining nozzle holder assemblies using the same method.

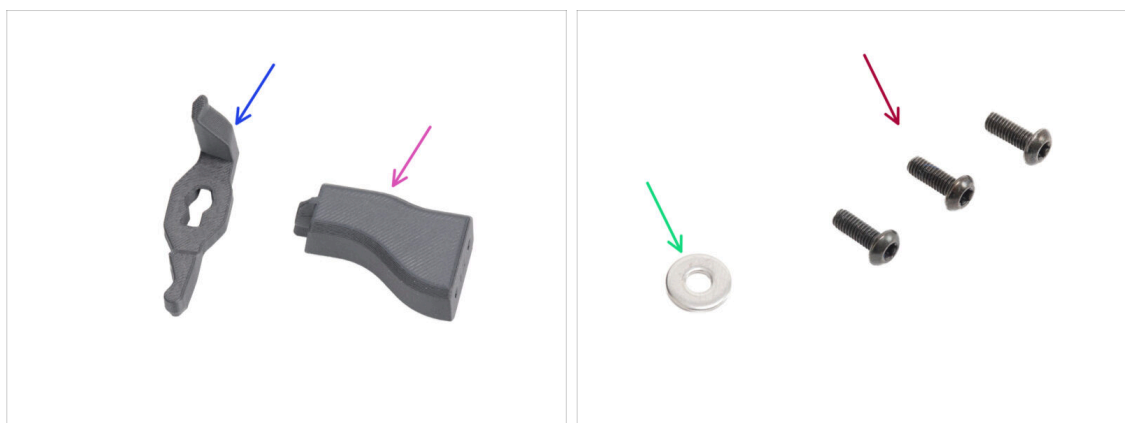
PASSO 74 Ventilation lever: parts preparation

- ◆ **Per i seguenti passi prepara:**
- ◆ INDX-C1-Vent-lever (1x)
- ◆ INDX-C1-Vent-lever-holder (1x)
- ◆ M3 washer (1x)
- ◆ M3x8rT screw (3x)

PASSO 75 Assembling the ventilation lever



- Place the Vent-idler onto the Vent-idler-holder **in the same orientation**.
- Secure it with an M3x8rT screw.
 - **Place an M3 washer under the screw.**
- From the inner side of the front profile, align the part with the two holes.
 - Note the “**TOP**” marking on the Vent-lever-holder. It **must face upward toward** the bent section of the front profile.
- From the opposite side (front) secure it with two M3x8rT screws.

PASSO 76 Top cover: parts preparation I.



- Per i seguenti passaggi prepara:
 - INDX-C1-grill-flexi (2x) *found in the Top Cover Parts bag*
 - INDX-C1-cover-latch (2x) *found in the Top Cover Parts bag*
 - INDX-C1-cover-knob (2x) *found in the Top Cover Parts bag*
 - M3x12cT screw (2x) *found in the Fasteners 2/2 bag*
 - M3x8rT screw (2x) *found in the Fasteners 2/2 bag*
 - M3x8 screw (2x) *found in the Fasteners 1/2 bag*

PASSO 77 Top cover: parts preparation II.

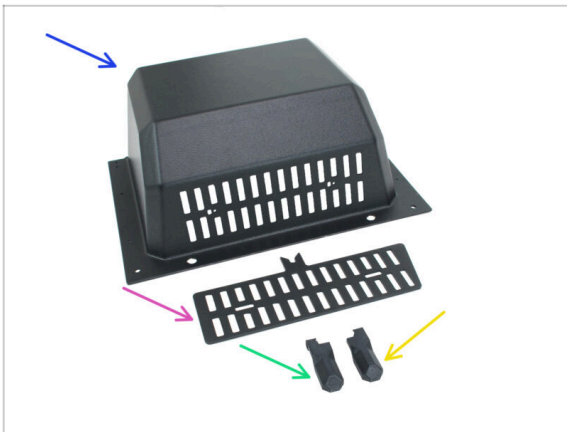

- Per i seguenti passaggi prepara:
 - Top cover (1x) *found in the main box*
 - Grille (1x) *found in the main box*
 - INDX-C1-hinge-cover-left (1x) *found in the Top Cover Parts bag*
 - INDX-C1-hinge-cover-right (1x) *found in the Top Cover Parts bag*

PASSO 78 Attaching the hinge covers



- Turn the top cover upside down and attach the Hinge-cover from the bottom.
- Secure each Hinge-top with two M3x12cT screws.
- ⚠ **Make sure that you do not overtighten the screws.**

PASSO 79 Montaggio della griglia



- Place the grill onto the top cover.
- Note the correct position of the grill. Ensure that it looks exactly as shown in the photo.
- Insert the INDX-C1-grill-clamps and hold them in position.
- Secure the grill in place with two M3x8T screws.

PASSO 80 Attaching the left cover lock



- Insert the INDX-C1-cover-latch into the top cover from the bottom. Note the orientation of the cover latch.
- Attach the INDX-C1-cover-knob. Ensure that the knobs on the cover latch align with the holes in the cover knob. Press both parts together.
- Secure the cover lock in place with the M3x8 screw.



Do not overtighten the screw. The lock must be able to turn.

PASSO 81 Attaching the right cover lock



- ◆ Insert the INDX-C1-cover-latch into the top cover from the bottom. Note the orientation of the cover latch.
- ◆ Insert the INDX-C1-cover-latch into the top cover from the bottom. Note the orientation of the cover latch.
- ◆ Secure the cover lock in place with the M3x8 screw.
- ⚠ Do not overtighten the screw. The lock must be able to turn.

PASSO 82 Top cover back: parts preparation



- ◆ Per i seguenti passaggi prepara:
 - ◆ Top cover back (1x) *found in the main box*
 - ◆ Hinge-base (2x) *found in the bag*
 - ◆ M3x12sT screw (2x) *found in the Fasteners 2/2 bag*
 - ◆ M3x25 screw (2x) *found in the Fasteners 1/2 bag*
 - ◆ Nylon rivet (2x) *found in the Fasteners 1/2 bag*
 - ◆ Spring 0,63x5x15x11 (2x) *found in the Fasteners Tools bag*

PASSO 83 Attaching the top cover back



- Place the top cover back on the printer.
- Secure the top cover back in place with two nylon rivets.

PASSO 84 Attaching the hinge base - left



- Place the Hinge-base near the front left hole in the top cover back.
- Note that each Hinge-base part indicates which side it goes to. Ensure that the part is marked with an L (left).
- Insert the M3x8rT screw from inside the printer and hold it in position.
- Align the hole in the Hinge-base with the M3x12sT screw and connect the Hinge-base to the printer.
- Tighten the M3x12sT screw while holding the Hinge-base in place.

PASSO 85 Attaching the hinge base - right

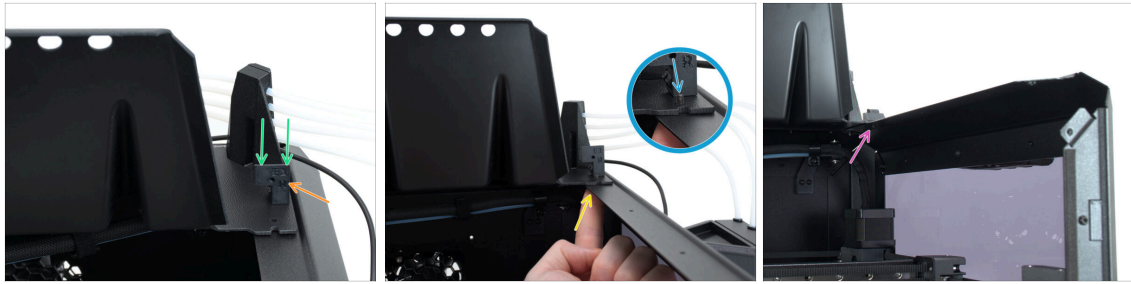

- Place the Hinge-base near the front left hole in the top cover back.
- Note that each Hinge-base part indicates which side it goes to. Ensure that the part is marked with an L (left).
- Insert the M3x8rT screw from inside the printer and hold it in position.
- Align the hole in the Hinge-base with the M3x12sT screw and connect the Hinge-base to the printer.
- Tighten the M3x8rT screw while holding the Hinge-base in place.

PASSO 86 Attaching the top cover I.

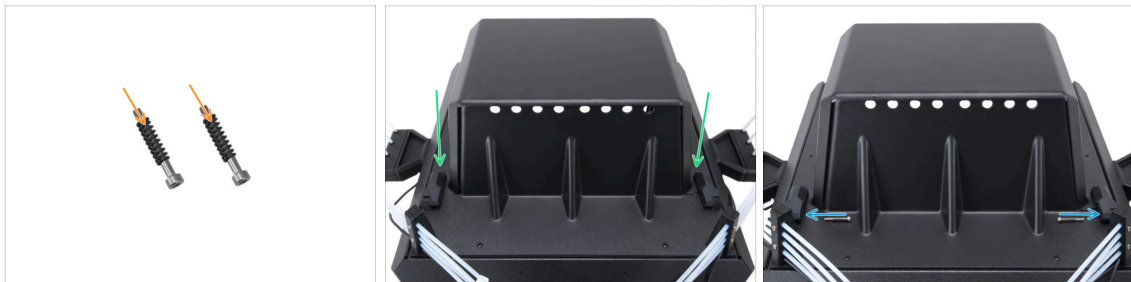

- Attach the Spring 0,63x5x15x11 on each of the M3x25 screws.
- Place the top cover on the printer. Make sure that both hinges are positioned correctly.
- Insert one Mx25 screw with the spring into each hinge from the inner side.

PASSO 87 Attaching the top cover II.



- Use an Allen key to tighten the M3x25 screw on the left hinge. Do not tighten it completely.
- Use an Allen key to tighten the M3x25 screw on the right hinge. Do not tighten it completely.
- Slowly open the top cover all the way.
- Make sure that the spring is able to retract and expand when opening the lid. This will hold the top cover open.
- ⓘ If the top cover does not stay open, check the tightness of the two M3x25 screws in the hinges and make sure the spring is in place.

PASSO 88 INDX Nozzle tool: parts preparation



- Per i seguenti passaggi prepara:
 - M3x4 screw (2x) that were removed earlier
 - Nylon rivets (2x) found in the Fasteners 1/2 bag
 - M3x4rT screw (2x) that were removed earlier
 - INDX CHT Nozzle tool (8x)
- ⚠ **Warning: Avoid touching or damaging the rectangular sensing area on the INDX CHT Nozzle tool. Fingerprints, grease, or any damage can affect temperature readings and cause print issues.**

PASSO 89 Attaching the tooldock

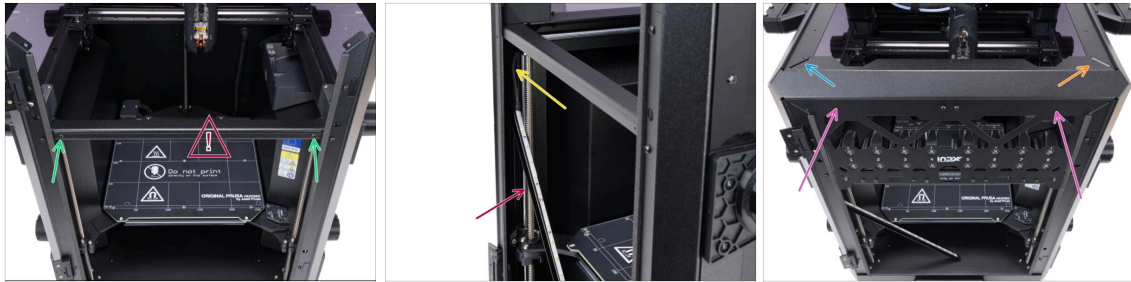

- ◆ Remove the two M3x4rT screws that hold the LED panel in place. Set the screws aside, we will need them very soon.
- ⚠ Support the LED panel with your hand when removing the screws, so it does not fall. **Do not touch the LEDs and resistors on the LED strip!**
- ◆ Gently lean the LED panel on the left side of the printer.
- ◆ Make sure that the LED cable is not damaged or pulled too hard during these steps.
- ◆ Mount the assembled tooldock.
- ◆ The left side of the tooldock has to go under the top profile.
- ◆ The right side of the tooldock has to go over the top profile.

PASSO 90 Fissare il tooldock

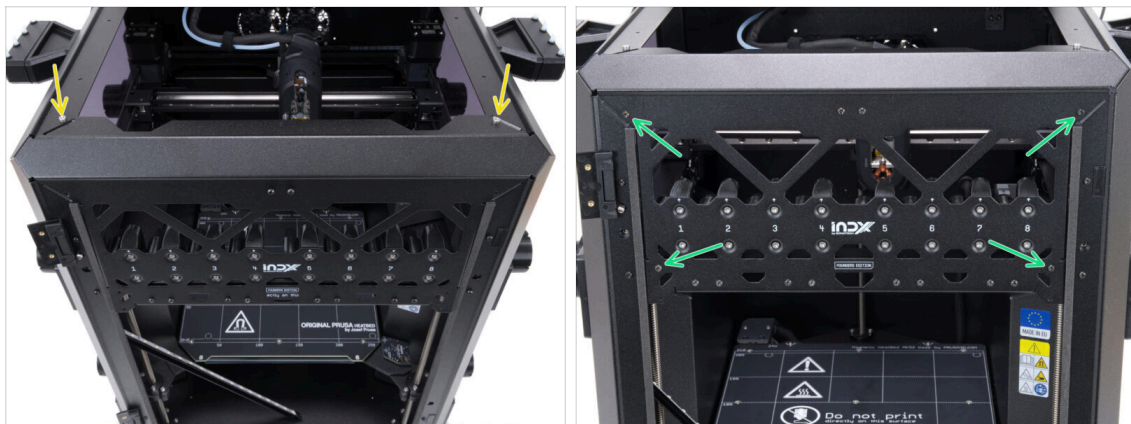

- ◆ Secure the tooldock to the top profiles with one M3x4 screw on each side.
- ◆ Secure the tooldock to the front of the printer with four M3x4rT screws.

PASSO 91 Montaggio del pannello LED



- ◆ Mount the LED panel onto the tool dock. Do not touch LEDs and resistors on the LED strip!
- ⓘ The LED cable should reach the new position of the LED panel. If the cable is too short, **gently and slowly** pull on it to make it the correct length.
- ◆ Use two nylon rivets to secure the LED panel in place.
- ◆ Close the top cover.

PASSO 92 Optional: Installing the Buddy3D Camera



- ⓘ This step is only required if you have a Buddy3D Camera.
- ◆ Now is the right time to mount the camera in the front-left corner of the printer.
- ◆ Use the dedicated installation guide: Buddy3D Camera for CORE One Installation
- ⓘ The guide shows installation on the CORE One, but the procedure is the same. The camera attaches magnetically to the upper profiles of the printer.

PASSO 93 Connecting the INDX Nozzle tools (positions 1-4)



- Close the top lid.
- Insert the PTFE tubes through the openings on the back of the lid, **keeping the correct order**.
 - Insert the PTFE tube from position 1 into the first opening from the right.
 - Repeat the same process for the remaining positions. **Always make sure each PTFE tube is routed through the matching opening in the lid.**
- Open the lid and, from the inside, fully insert the **PTFE tube from the first opening** into the INDX CHT Nozzle Tool at **position 1**.
 - Gently pull the tube to verify it is locked in the collet.
- Repeat the same procedure for all tools in positions 1-4.

PASSO 94 Docking the tools (positions 1-4)

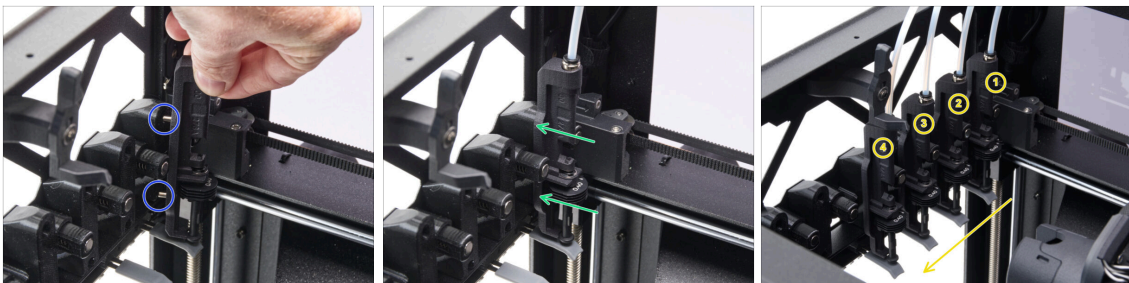

- Place the INDX CHT Nozzle tool **on the first PTFE tube** onto tool dock **position 1** and align the magnetic pins on the tool with the openings in the tool dock.
- Snap the INDX CHT Nozzle tool it into tool dock **position 1**.
 - ⚠ **Make sure both pins snap in fully and the tool sits perfectly flush.**
- Repeat the same procedure for the remaining tools up to position 4.
- ⓘ Double-check that the **nozzle parking plates are in the correct position** to seal the INDX CHT Nozzle tool.

PASSO 95 Connecting the INDX Nozzle tools (positions 5-8)



- Close the top lid.
- Insert the PTFE tubes through the openings on the back of the lid, **keeping the correct order**.
 - Insert the PTFE tube from **position 8** into the **first opening from the left**.
 - Repeat the same process for the remaining positions. **Always make sure each PTFE tube is routed through the matching opening in the lid.**
- Open the lid and, from the inside insert the **PTFE tube from the rightmost opening** into the INDX CHT Nozzle Tool at **position 8**.
 - Gently pull the tube to verify it is locked in the collet lines.
- Repeat the same procedure for all tools in positions 8-5.

PASSO 96 Docking the tools (positions 5-8)

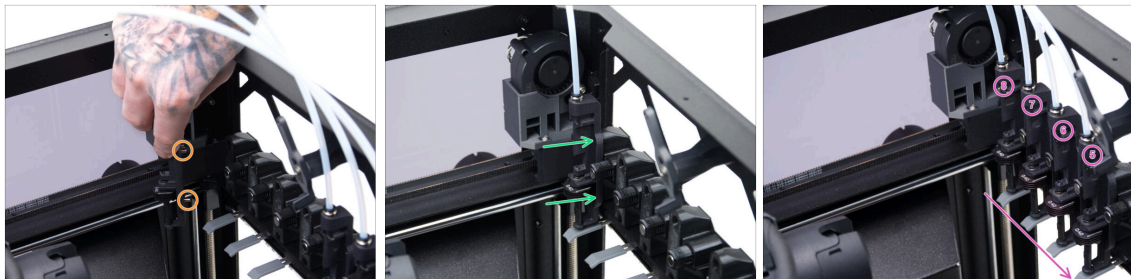

- Place the INDX CHT Nozzle tool **on the last PTFE tube** onto tool dock **position 8** and align the magnetic pins on the tool with the openings in the tool dock.
- Snap the INDX CHT Nozzle tool it into tool dock **position 8**.
 - ⚠ **Make sure both pins snap in fully and the tool sits perfectly flush.**
- Repeat the same procedure for the remaining tools up to position 5.
- ⓘ Double-check that the **nozzle parking plates are in the correct position** to seal the INDX CHT Nozzle tool.

PASSO 97 Checking the tubes



- ⚠ Check that the PTFE tubes are not swapped and that each tube is correctly routed to the corresponding tool position.
- 🟢 You can now close the lid and secure it by rotating the locks by 90°.
- 📄 **This is optional at this stage**, as the lid will need to be opened again later during calibration.
- 🔵 Remove the empty cardboard box from the printer, as it will no longer be needed.

PASSO 98 Offset sensor cover: parts preparation

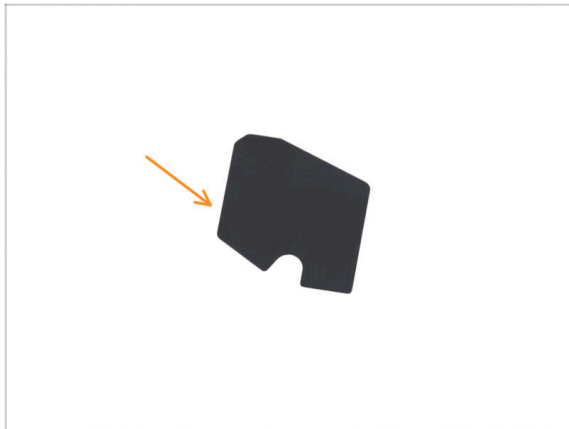

- ⬛ Per i seguenti passaggi prepara:
- 🟠 Offset sensor sticker (1x) *found in the Tool Dock Fan bag*
- 📄 The color of the offset sensor sticker might differ, but it does not affect the functionality.

PASSO 99 Covering the offset sensor

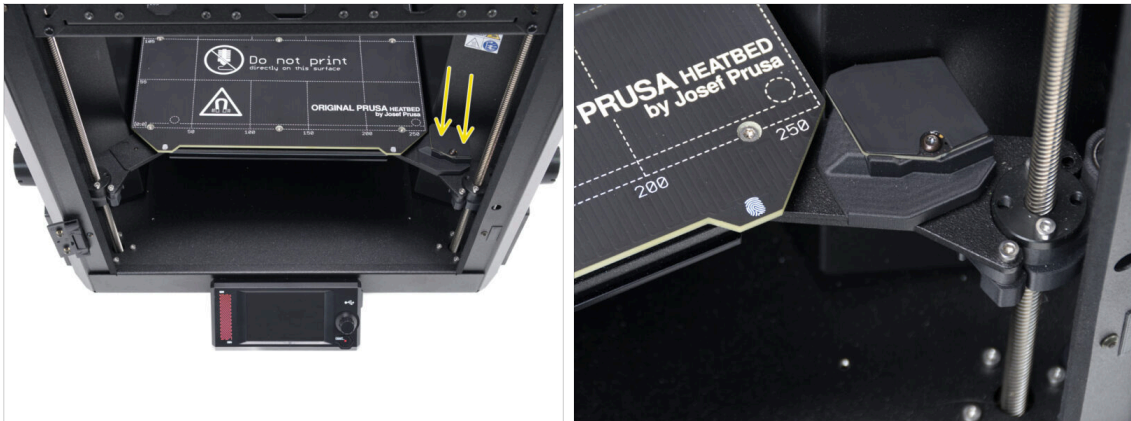

- Peel the protective layer off the offset sensor sticker and gently place the sticker onto the FunFan board.
- Ensure that the sticker covers the whole board.

PASSO 100 Pannello dello sportello: preparazione dei componenti



- **Per i seguenti passi prepara:**
- Door panel assembly (1x) *you removed earlier*
- Vite M3x5rT (4x) *rimosse in precedenza*
- Top door seal (1x)

PASSO 101 Montare il pannello dello sportello

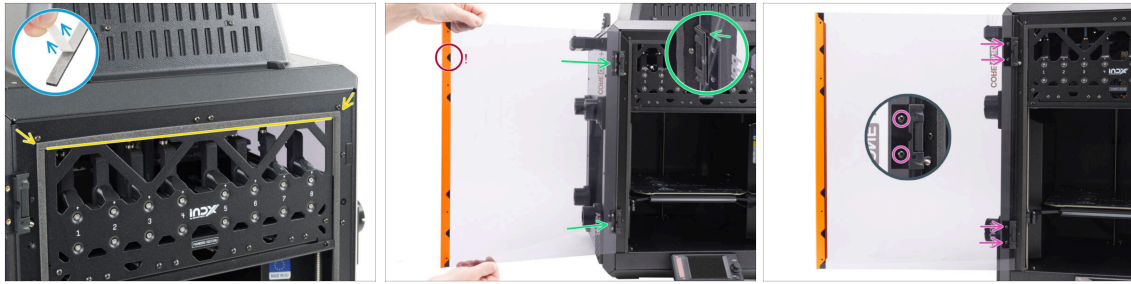

- ◆ Peel away the bottom backing layer of the gasket to expose the adhesive surface.
- ◆ Align the gasket on the front profile with the adhesive side facing the surface, then press it down to adhere.
- 📌 If you had any issues with the shaft falling out of the hinge, assemble the hinge now, before mounting the door panel.
- ◆ Inserisci il pannello dello sportello completamente nelle cerniere.
- ⚠️ **Ensure the door panel is oriented correctly, with the handle facing outward. Use the V-shaped cutouts on the inner side of the door handle as a guide.**
- ◆ Inserisci due viti M3x5rT in ogni cerniera dello sportello per fissare il pannello dello sportello.
- ◆ **Secure the screws gently** to avoid over-tightening or damaging the door panel.

PASSO 102 Haribo time !

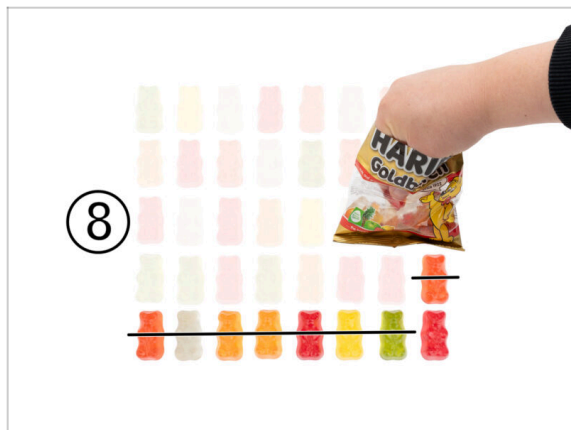

- ◆ You're almost there. Take a break and get ready for the final chapter.
- ◆ Mangia otto orsetti gommosi.
- ⓘ Now you have only one gummy bear left. Maybe more, depending on the factory filling. But we have one more reward coming, so keep the rest aside!

PASSO 103 Questo è tutto



- ◆ **Congratulations!** You have successfully upgraded to the INDX Founders Edition.
- ⓘ Next, you only need to run the self-test and basic calibration.
- ◆ **Proceed to the next chapter.**

6. Controllo finale

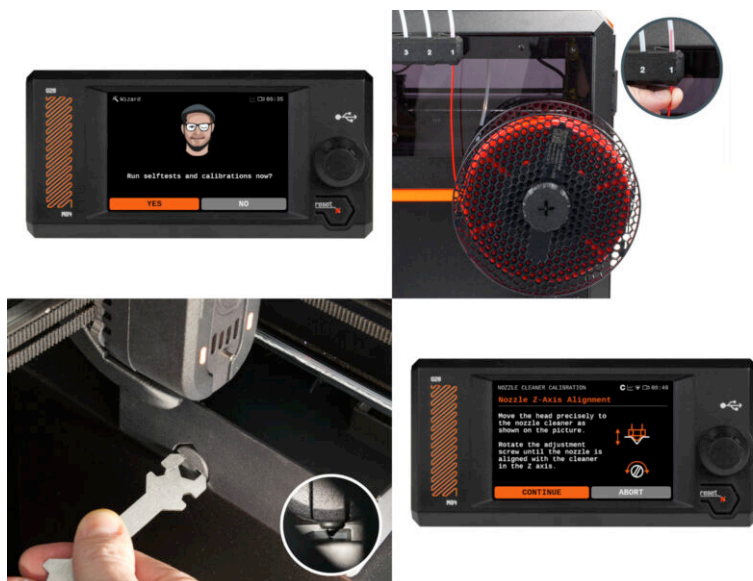

PASSO 1 Montaggio del porta bobina: preparazione dei componenti

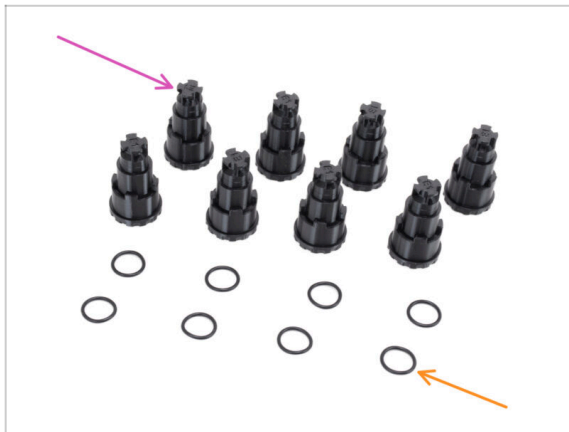

- Per il prossimo passo, prepara:
 - ◆ Spoolholder-static (8x)
 - ◆ O-ring (8x)
- ⓘ Il porta bobina e l'O-ring sono nella stessa busta.

PASSO 2 Locking the spool holders



- ◆ Metti l'O-ring sulla parte del porta bobina Spoolholder-static.
- ◆ Push the Spoolholder-static into the Puck-universal dock.
- ◆ Blocca la parte Spoolholder-static ruotandolo **in senso orario**.

🔧 Ripeti la stessa procedura per i restanti portabobina.

PASSO 3 Fissare la piastra di stampa



- ⚠ **Assicurati che non ci sia nulla sul piano riscaldato.** Il piano riscaldato deve essere pulito in quanto lo sporco può danneggiare la superficie del piano riscaldato e della piastra di stampa.
- 📍 **Inserisci la piastra allineando prima il foro posteriore con i perni di bloccaggio sul retro del piano riscaldato.** Tieni la piastra per i due angoli anteriori e stendila lentamente sul piano riscaldato - **attenzione alle dita!**
 - 🛡 Mantieni pulita la piastra di stampa per ottenere le prestazioni ottimali.
 - 🛡 La causa numero 1 del distacco delle stampe dalla piastra di stampa è dovuto ad una piastra di stampa unta. Se hai già toccato la sua superficie, usa dell'IPA (alcol isopropilico) per sgrassarla.

PASSO 4 Aggiornamento Firmware



- 🛡 Visita la pagina help.prusa3d.com.
- 📍 Navigate to the CORE One INDX page.
- 🟢 Scarica l'ultima versione del firmware.
- 🛡 Salva il file del firmware (.bbf) sulla chiavetta USB in dotazione.

PASSO 5 Accendere la stampante



- ◆ Inserisci nella stampante la chiavetta USB inclusa nel kit.
 - ⓘ La chiavetta USB inclusa contiene il file del firmware più recente.
- ◆ Inserisci il cavo di alimentazione e collega la stampante a una presa di corrente.
- ◆ Accendi la stampante utilizzando l'interruttore sul retro.
- ⓘ A questo punto la stampante rileverà se sulla chiavetta USB è disponibile un nuovo file del firmware.
- ◆ Se appare la schermata "Nuovo firmware disponibile", seleziona **FLASH** premendo la manopola per aggiornare al firmware più recente.

PASSO 6 Impostazione della stampante: Introduzione

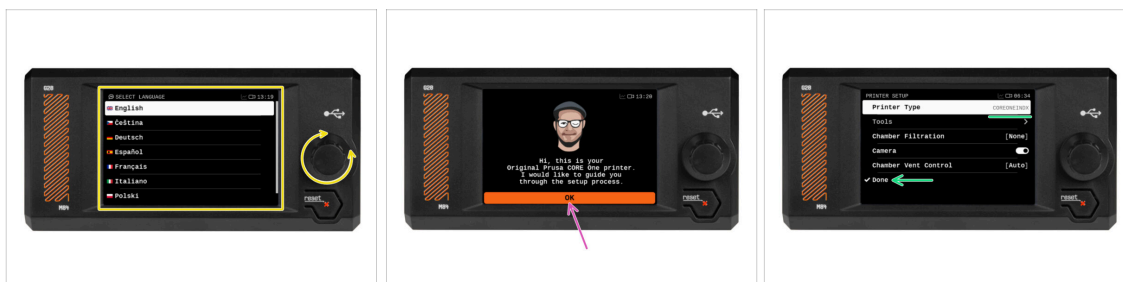

- ◆ La stampante visualizza sullo schermo una richiesta di selezione della lingua. Usa la manopola di controllo o il touchscreen per impostare la tua scelta.
- ◆ Dopo aver selezionato la lingua, la stampante visualizzerà la schermata di benvenuto. Premi **OK** per continuare il processo di configurazione.
- ◆ The next screen will prompt you to select your printer model COREONEINDX. Hit **Done** to continue.

PASSO 7 Configurazione della stampante: Configurazione della rete



- La schermata di configurazione della rete ti chiederà di connetterti a una rete Wi-Fi utilizzando l'app mobile ufficiale di Prusa.
 - ⓘ Per saperne di più prusa.io/app.
- Se selezioni **No**, la stampante mostrerà modi alternativi per connettersi al Wi-Fi. Questo passaggio è facoltativo e può essere eseguito in un secondo momento.
 - ⓘ Puoi saltare questa schermata e impostare la connessione di rete in un secondo momento.

PASSO 8 Wizard: Intro

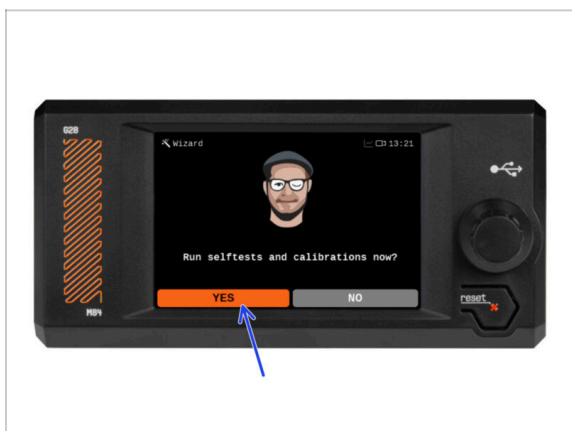

- ⓘ La stampante ti chiederà di eseguire autotest e calibrazioni per tutti i componenti più importanti. L'intero processo richiede pochi minuti, mentre alcune parti richiedono l'interazione diretta dell'utente.
- Premi **Si** per iniziare l'autotest e segui le istruzioni sullo schermo.
- ⚠ **Durante l'autotest, tieni lo sportello chiuso finché non ti viene richiesto. L'apertura dello sportello interromperà il processo.**
- **Durante l'autotest, all'interno sono presenti parti CALDE e in movimento.**
- ⓘ Alcuni dei test automatici che non richiedono un intervento diretto da parte dell'utente non sono menzionati in questa guida.

PASSO 9 Wizard: Door sensor calibration



- i** This step can be skipped. The door sensor is only calibrated during assembly and has a dedicated calibration section at the end of its own guide.
- ◆** Hit the **Skip** button to proceed to the next calibration.
- ◆** Segui le istruzioni visualizzate sullo schermo. La stampante eseguirà ora il test automatico degli assi X e Y e la calibrazione dell'allineamento dell'asse Z.

PASSO 10 Wizard: Tensionamento della cinghia

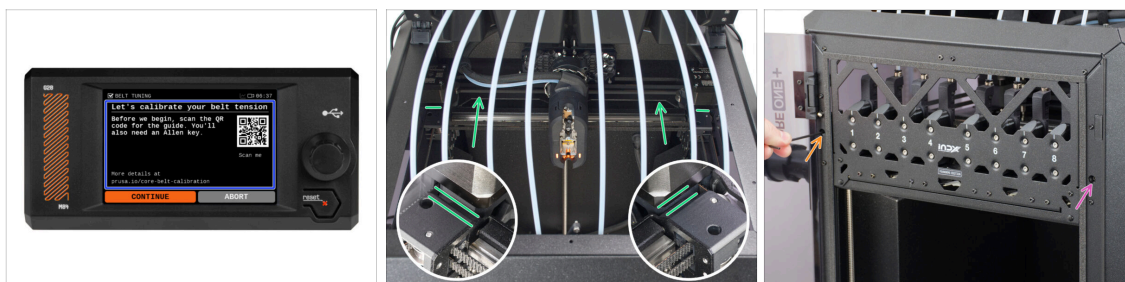

- ◆** The printer will now prompt you to fine-tune the belts. Follow the on-screen instructions.
- ◆** Apri il coperchio superiore e sposta manualmente la testina dello strumento INDX il **più indietro possibile**, verificando che **non ci siano spazi tra i fermi a sinistra e a destra**.
- ⚠** **ATTENZIONE: una procedura errata può causare danni alle parti in plastica o il grippaggio delle viti. Prima di regolare la tensione della cinghia, leggi l'articolo dedicato:**
 - ◆** Adjusting **belt tension (CORE One)**
 - ◆** The belts are adjusted using the tensioning mechanism on each side for each belt:
 - ◆** La **vite di sinistra** serve a regolare la **cinghia superiore**.
 - ◆** The **right screw** adjusts the **lower belt**.
 - ◆** Una volta regolate alla perfezione le cinghie, premi **Continua** e segui le istruzioni sullo schermo.

PASSO 11 Wizard: Calibrazione del dock (parte 1)



- ◆ Once the automatic homing calibration is complete, calibrate the docks. Hit **Continue** and follow the on-screen instructions.
- ◆ The printer will ask you to enter the number of docks on your printer.
 - ◆ It means how many tool dock positions are installed on the front profile (nozzle holders). This is typically 4 or 8.
- ◆ On the next screen, ensure that all dock positions are **set to** and not to .
- ◆ Una volta che tutti i dock sono pronti per la calibrazione, scorri verso il basso e clicca su **Continua**.

PASSO 12 Wizard: Calibrazione del dock (parte 2)

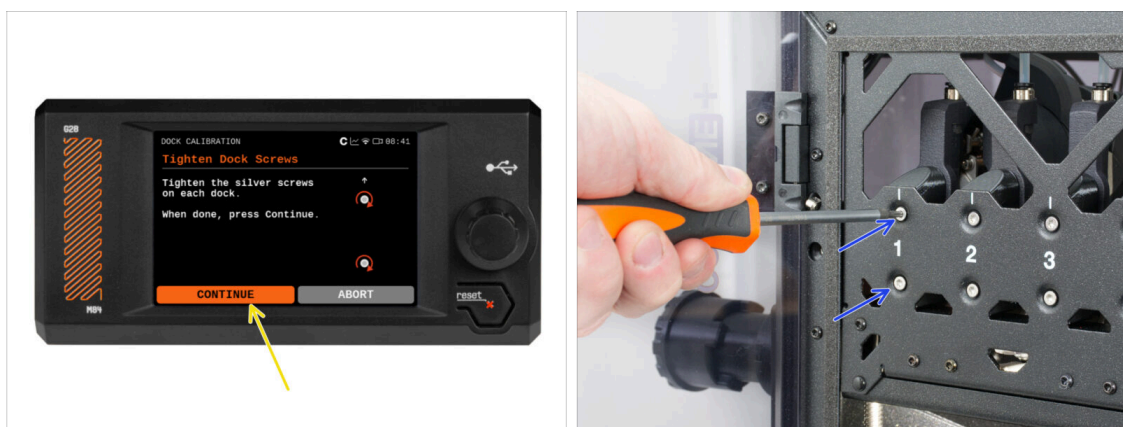

- ◆ The screen will now prompt you to tighten the silver screws securing each dock to the front profile.
 - ◆ Use a T10 key/screwdriver to tighten the silver screws **in all positions**.
 - ◆ **Do not overtighten them**, as they will be loosened again later.
 - ◆ Fai clic su **Continua**.
- ⓘ Make sure to **follow the on-screen guide in the next step**. The printer will inform you when it is safe to touch it and calibrate the docks.

PASSO 13 Wizard: Dock calibration (part 3)



Keep the top lid open.

- Non viene richiesto di posizionare manualmente la testina sul dock.
- From above, carefully slide the INDX Tool head onto tool dock **position 1** by hand.
 - Watch the alignment from above to ensure the **head seats perfectly onto the hotend**.
 - Once properly seated, you will feel a click indicating the correct position.
- Clicca su **Continua** e ripeti la stessa procedura per gli altri dock, **seguendo le istruzioni sullo schermo**.
- After all docks have been aligned, loosen the silver screws securing all dock positions by one full turn.

PASSO 14 Wizard: Loadcell Test



- La fase successiva della procedura guidata ti chiederà di toccare l'ugello per testare e calibrare la cella di carico. Durante questa procedura, **le parti della stampante non vengono riscaldate** in modo da poterle toccare. Premi su **Continua**.

i La calibrazione della cella di carico richiede che lo sportello sia aperto, in quanto è necessario interagire direttamente all'interno della stampante.

- Non toccare ancora l'ugello, ma attendi che venga visualizzato il messaggio **Tocca l'ugello ORA**.

- Tocca l'ugello dal basso. Se la cella di carico non rileva il tocco, ti verrà richiesto di ripetere il passaggio. In caso contrario, quando il test della cella di carico ha avuto successo, verrà visualizzato il messaggio **Test Cella di carico OK**.

- Per consentire alla stampante di continuare la configurazione guidata, **chiudi lo sportello**.



Al termine di questo test, la stampante eseguirà il test automatico dell'asse Z.

PASSO 15 Wizard: Fan test



- The printer will test all the fans during this process. Be aware—it can get quite noisy for a while!

PASSO 16 Wizard: Tool offsets calibration



- Select **Continue**, and the printer will proceed with testing the offsets for each toolhead.

PASSO 17 Wizard: Calibrazione del pulitore degli ugelli



- Nei passaggi seguenti, è possibile calibrare l'ugello con il contenitore del rasciutto.
- Once you press **Continue**, the Toolhead will move itself closer to the priming block on the nozzle cleaner.
- Nel tooldock, **nella posizione 8, è presente un'apertura** attraverso la quale puoi osservare direttamente l'allineamento degli ugelli.
 - ⓘ Se guardi attentamente attraverso l'apertura, vedrai l'incavo a forma di V nel contenitore e i blocchi di pulizia.
- Manually move the head above the bin on the right side of the printer. Position it in the middle of the priming block as shown on the screen.
- Through the opening, observe and align the head with the V-shaped cutout in the front priming block, as shown on the screen.

PASSO 18 Wizard: Nozzle cleaner calibration Z/X-axis

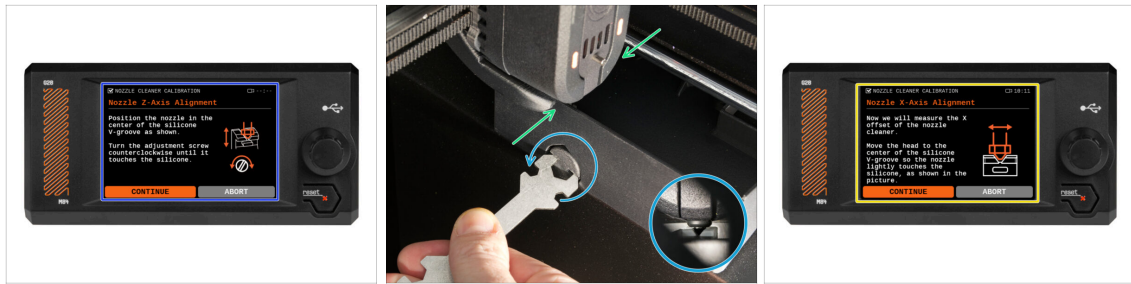

- La stampante ti chiederà ora di allineare il pulitore dell'ugello.
- Regola manualmente la posizione della testina in modo che l'ugello si trovi nell'**incavo a forma di V del raschietto in silicone**. Controlla l'allineamento attraverso l'apertura frontale del tooldock.
- Use the universal wrench to **precisely adjust** the Wiper-adjuster until the nozzle **fully fills the V-shaped cutout**, touching both angled sides and the bottom. Check the alignment through the opening.
- **i** The Wiper-adjuster allows the bin position to be adjusted up or down.
- Once the position is correctly set (see reference detail), select **Continue** and follow the on-screen instructions.
- The printer will lock the motors and warn you to **remove your hands from the printer** before proceeding with the calibration.

PASSO 19 Wizard: Calibrazione del Pulitore ugello sull'asse Y



- Now, the printer screen prompts you to align the nozzle on the Y-axis.
- Manually move the INDX Tool head into the V-shaped cutout on the left side of the nozzle cleaner bin and **precisely align it**. The nozzle must not touch the walls.
- The correct cutout is marked with "Y"
 - Guarda attraverso lo sportello aperto.
 - Once the alignment is perfect, press **Continue** and follow the on-screen instructions.
 - The printer will lock the motors and warn you to **remove your hands from the printer** before proceeding with the calibration.

PASSO 20 Wizard: Calibrazione dei sensori di filamento

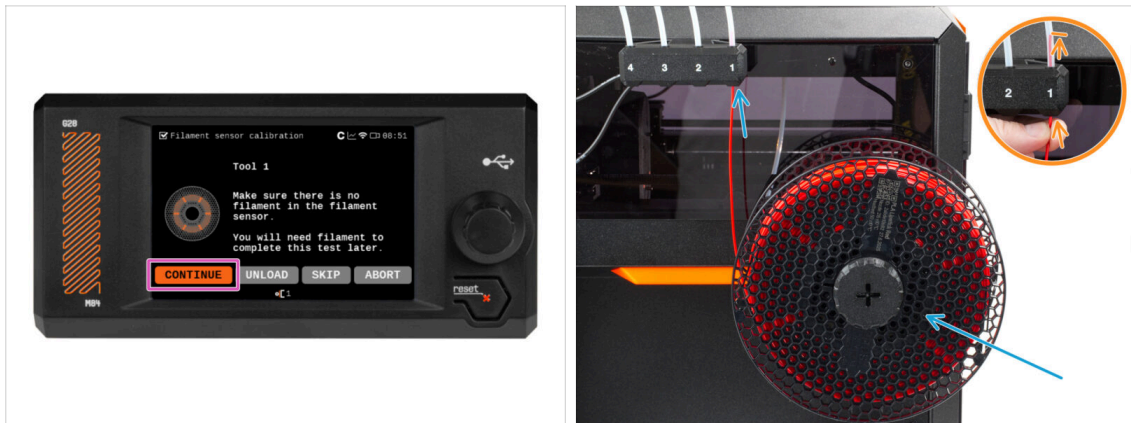

- ◆ During each tool filament sensor calibration, you will need a short piece of filament. Prepare the filament and select **Continue**.
- i Prima che inizi il processo di calibrazione, all'interno dell'estrusore non dovrebbe esserci **nessun filamento**.
- ◆ Posiziona la bobina di filamento sul porta bobina e, **quando richiesto**, fai passare il filamento nel sensore di filamento alla **posizione 1**.
 - ◆ Inserisci il filamento **solo attraverso il sensore del filamento**; non è necessario farlo passare per tutta la lunghezza del tubo in PTFE.
- ◆ After calibration finishes press **Continue** to calibrate the next position.
- 📌 Once all the positions are calibrated, continue to the automatic calibrations of phase stepping and input shaper.

PASSO 21 Wizard complete



- ◆ Congratulations! The Wizard is complete. Now let's test some prints.

PASSO 22 Haribo time!



- Tutto il tuo duro lavoro ha dato i suoi frutti, ed è ora di goderti la ricompensa finale. Mangia tutti gli orsetti gommosi adesso.

PASSO 23 Nozioni base Prusa

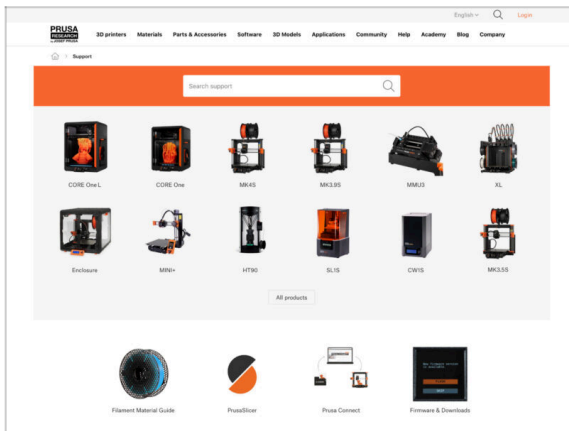

- Vai alla pagina del prodotto **CORE One/+ INDX** all'indirizzo prusa.io/coreone-indx e vai alla sezione **Guida introduttiva** per ulteriori informazioni e risorse.
- You can also find more information at help.prusa3d.com:
 - 📌 Trova download di software, manuali dei prodotti e guide dettagliate per il montaggio.
 - 📌 Dai un'occhiata ai suggerimenti e alle soluzioni per risolvere i problemi più comuni.
 - 📌 Tutorials and articles to help you get the most out of your printer.
- 📘 Aggiungiamo nuovi argomenti ogni giorno!

PASSO 24 Give us feedback



◆ Sappiamo che non vedi l'ora di iniziare a stampare, ma ti saremmo davvero grati se potessi dedicare 3-4 minuti per **condividere con noi le tue opinioni** su questo manuale: quanto è stato chiaro, quanto è stato facile da seguire e qualsiasi idea per migliorarlo.

❗ Questo feedback è un po' diverso dai soliti commenti che puoi lasciare sui singoli passi.

◆ **Condividi il tuo feedback qui.**

◆ Grazie per averci aiutato a rendere i nostri manuali ancora migliori!

PASSO 25 Join Printables!

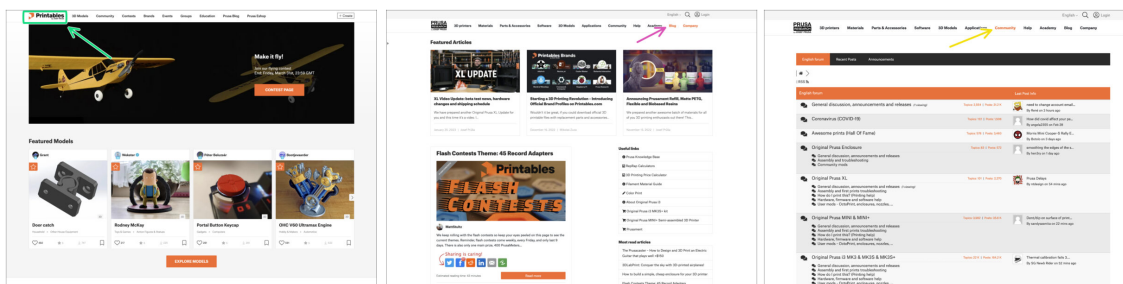

◆ Non dimenticare di unirti alla community Prusa più numerosa! Scarica gli ultimi modelli in STL o i G-code fatti su misura per la tua stampante. Registrati su [Printables.com](https://www.prusa.com)

◆ Cerchi ispirazione per nuovi progetti? Controlla il nostro blog per gli aggiornamenti settimanali.

◆ Se hai bisogno di aiuto nel montaggio, dai un'occhiata al nostro forum con una splendida community :-)

❗ Tutti i servizi Prusa condividono lo stesso account utente.

